

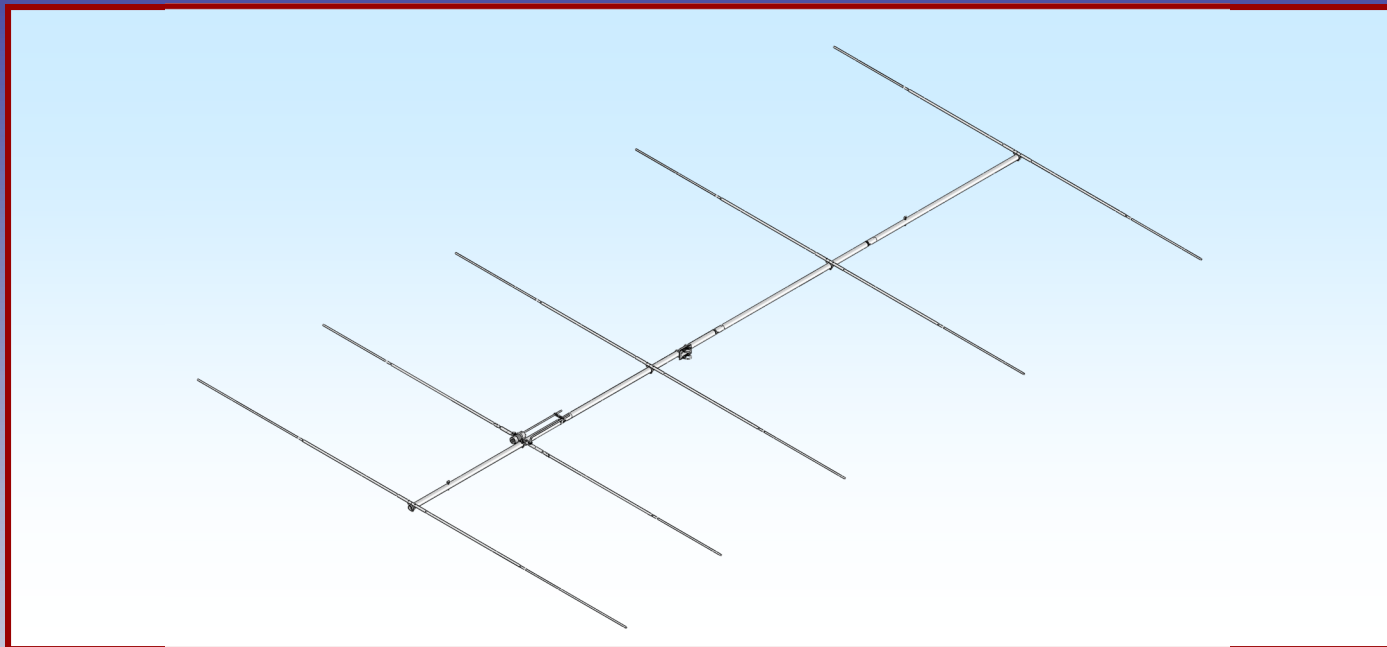

M2 Antenna Systems, Inc. Model No: 11M5DX



SPECIFICATIONS:

Model	11M5DX	Power Handling	3 kW, Higher avl.
Frequency Range.....	26.8 To 27.6 MHz	Boom Length / Dia.....	26.7' / 2"
*Gain	10.44 dBi	Maximum Element Length.....	18.75'
Front to back	24 dB Typical	Turning Radius:	14.8'
Beamwidth	E=34° H=39°	Stacking Distance.....	Call Factory
Feed type	Direct feed	Mast Size.....	2" Nom.
Feed Impedance.	50 Ohms Unbalanced	Wind area / Survival	5.13 Sq. Ft. / 100 MPH
Maximum VSWR.....	1:1 Typical	Weight / Ship Wt.....	30 Lbs. / 36 Lbs.
Input Connector.....	SO-239		

***Subtract 2.14 from dBi for dBd**

FEATURES:

The 11M5DX is a great performer for its size. IT'S UPSABLE! Like all our "DX" series. The computer optimized design allows full band coverage with good gain and front to back. Mechanically, CNC machined aluminum (6061-T6) rings clamp the elements to the boom and make assembly a snap. An overhead guy system is supplied. A hairpin type match couples the 3 kW 1:1 bal-un to the feed line. The antenna is completely DC grounded.

11M5DX ASSEMBLY MANUAL

Note: A cup of zinc paste (PENETROX, NOALOX, or equivalent) has been provided to enhance the quality of all the electrical joints in this antenna. Apply a thin coat wherever two pieces of aluminum come in contact PARTICULARLY IN THE DRIVEN ELEMENT MATCHING ASSEMBLY.

BOOM SETUP AND ASSEMBLY

1. Refer to the Dimension Sheet. Note the different boom sections and the approximate position of each element. LAYOUT the boom sections in order of assembly but do not couple together yet. Slide the appropriate size and number of RING CLAMPS into their approximate positions on ALL boom sections. Spread the ring clamp fingers with a flatblade screwdriver to ease movement on boom. Loosely add a 1/4-20 x 1" bolt and locknut to fingers of all clamps. NOW GO AHEAD AND ASSEMBLE THE BOOM. Add the two EYEBOLTS and tighten in place. Then POSITION each ring clamp accurately starting with the rear ring clamp. Final element alignment can be done once the antenna is fully assembled.

DRIVEN ELEMENT ASSEMBLY

2. Locate the two 1" x 12" swaged tube sections. Insert a 3/4 x 60" section into the swaged end and add the 8-32 x 1-1/4" screws and locknuts. SPACE PERMITTING, add the correct set of 1/2" tips and secure with 5/8" compression clamps. Locate the 7/8 x 15" center fiberglass section and slip the two white polyethylene rings on the rod centering them between the outer and inner holes on each side. Slide the two half element sections over the 7/8 x 15" center fiberglass rod insulator and add the 1/4-20 x 2" bolts and locknuts loosely through the outer holes in the rod.

Locate the balun mounting plate and drop two 1/4-20 x 2" bolts through the smaller holes in the plate and then down through the inner holes in the rod. Set this assembly onto the driven element ring clamp. Add the 1/4" locknuts and tighten. Mount the 1:1 balun to the plate using one 2-1/2" U-bolt and cradle. Orient the balun so the drain/vent hole is down and tighten the U-bolt gently.

3. Locate the 1/2" wide balun straps and connect one to each side of the balun finger tight. Now remove the loose bolts holding the element halves to the rod and insert the bolts up from the bottom, through the rod and element butt. Place two clamp blocks on each stud. Place the balun strap on the remaining stud and add the nuts loosely.

4. Locate the band clamp and insert a 1/4-20 x 2" bolt through the hole from the inside. Add the 3/8" x 1" spacer tube to the bolt and set the shorting bar on the spacer. Add a locknut and finger tighten. Slide the long, straight ends of the 3/8" hairpin tubes through the shorting bar and add the 1/4-20 x 1/4" set screws to each end of the shorting bar but don't tighten yet. Set the open band clamp on the boom just in front of the driven element and feed the hairpin tubes into the clamp block openings until they are flush with the back edges. Align the tubes and begin to tighten up the clamp block bolts.

5. Adjust the shorting bar position,(see dimension sheet) align and tighten the set screws. Now tighten the band clamp. RE-CHECK and tighten all the hairpin match assembly and driven element assembly hardware, including the balun studs.

PARASITIC ELEMENT ASSEMBLY

6. Assemble the other four pairs of elements. Insert two 1/4-20 x 2" bolts down through the 1" section and set each on the correct ring clamp on the boom. Add the 1/4-20 locking nuts and tighten.

11M5DX ASSEMBLY MANUAL

OVERHEAD GUY ASSEMBLY

7. If possible, attach the feedline to the balun and route it forward to about 12 feet from the rear of the boom. Seal the connector with black tape, coax seal or equivalent. Now pick up the antenna and mark the balance point. Center the BOOM TO MAST PLATE and secure to the boom with two 2"- U-bolts, cradles, stainless lockwashers and nuts. 2" U-bolts are supplied for attaching the antenna to the mast.
8. To prepare the overhead guy system, begin by *temporarily* installing a 2" U-bolt through the TURNBUCKLE PLATE and into the top set of 2" U-bolt holes on the boom to mast plate. Add a couple of 5/16" nuts to hold it in place. UNSCREW the turnbuckle eyes / hooks until only a thread or two shows inside the turnbuckle body and hook them to turnbuckle plate.
9. Uncoil DACRON CORD. Secure one end to rear eyebolt, taking two turns through the eyebolt, then adding three TIGHT half-hitches. Pull hard on cord to set the knots. Repeat for the front eyebolt. Seal cord ends with heat (lighter, propane torch, etc) and tape to main length.
10. Equalize cord length at turnbuckle plate and cut. Put two turns trough rear turnbuckle eye. Pull the Dacron rope as tight as possible and add three TIGHT half-hitches. Repeat for front cord section. Seal and tape cord ends. When finished the overhead guys should be taught and laying parallel with the boom. Now remove the turnbuckle plate from the boom to mast plate and lift it temporarily to note the approximate height at which the boom becomes level. (usually about 3 feet).
11. During final installation on the tower / mast, secure the turnbuckle plate at the appropriate height with the 2" U-bolt. Then lean or pull on the cords to increase the tension and help the knots take their final "set." Make sure the knots are not slipping. When the guy system has taken a "set", loosen the 2" U-bolt and adjust turnbuckle plate height until boom is straight and level. Finer adjustments can be made with the turnbuckles at any time, if necessary.
12. This completes the ASSEMBLY.

REMEMBER to support the feedline at the antenna boom and on the mast. Leave an adequate feedline loop for rotation around the tower. When stacking this antenna with other H.F. models, maintain at least 8' separation; more if practical. Mount horizontally polarized VHF and UHF antennas at least 40" above or below this antenna to minimize interaction.

Carefully designed and manufactured by:

M² ANTENNA SYSTEMS, INC.
4402 N. SELLAND AVE.
FRESNO, CA 93722
(559) 432-8873 FAX: 432-3059
www.m2inc.com Email: sales@m2inc.com

11M5DX DIMENSION SHEET

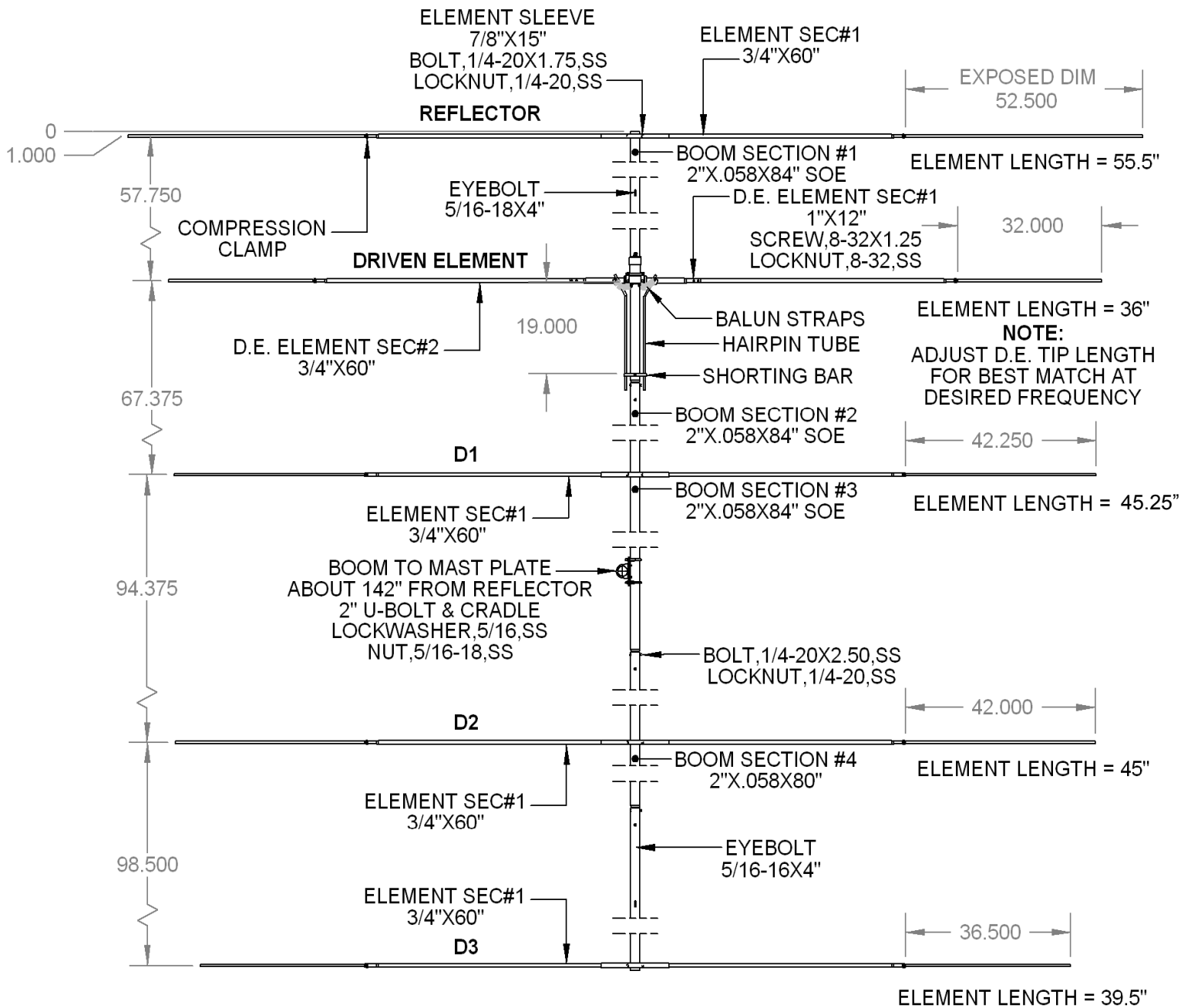

D.E., REFLECTOR & DIRECTOR DETAIL

DRIVEN ELEMENT ASSEMBLY

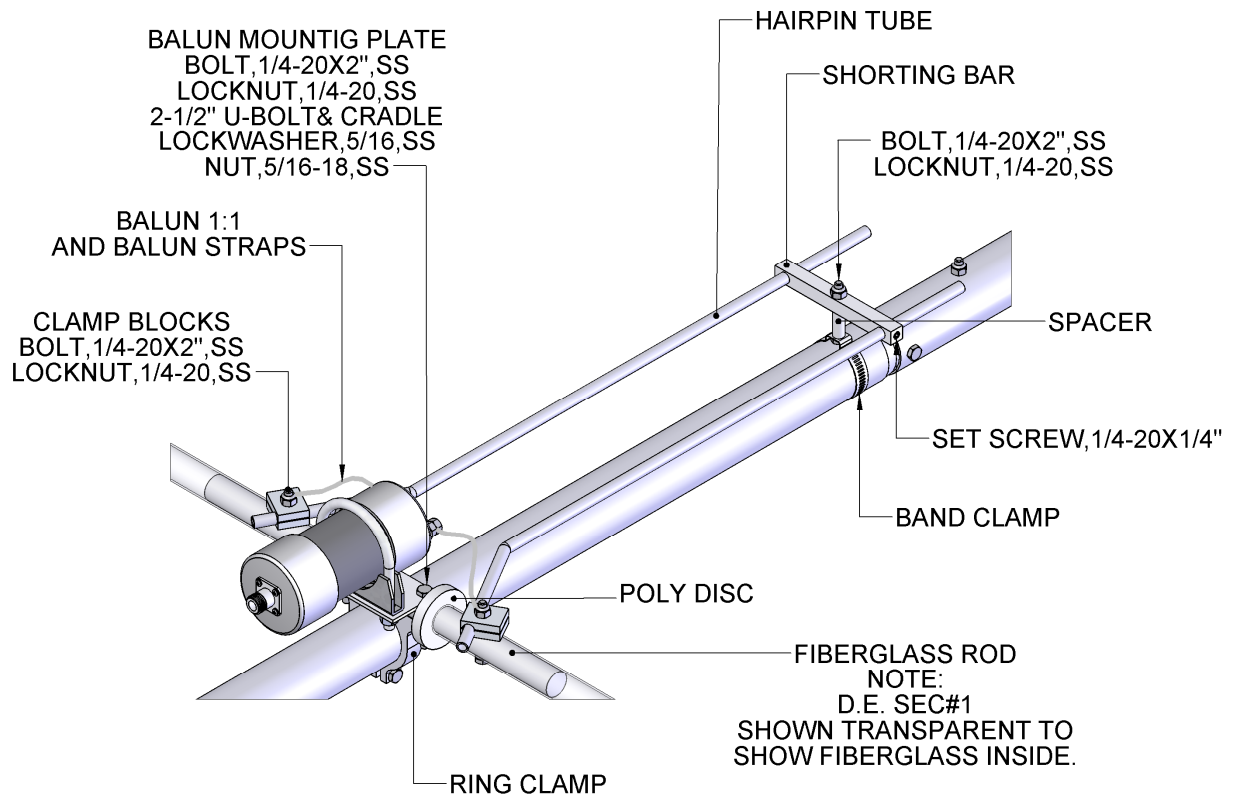

REFLECTOR & DIRECTOR ASSEMBLY

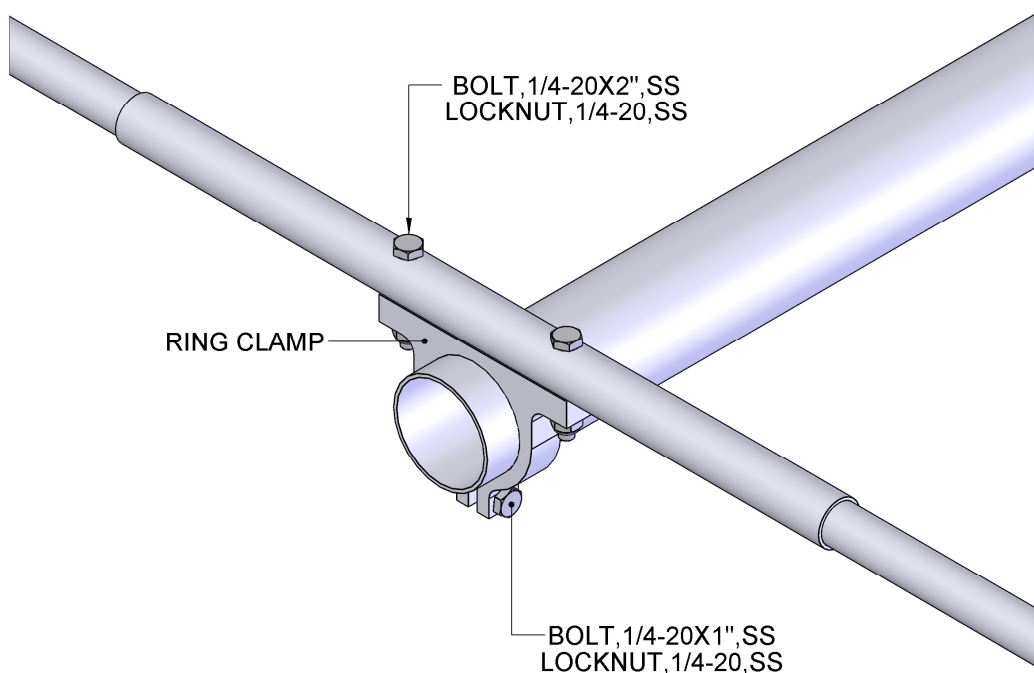

M² ANTENNA SYSTEMS, INC.

4402 N. SELLAND AVE.

FRESNO, CA 93722

(559) 432-8873 FAX: 432-3059

www.m2inc.com Email: sales@m2inc.com

GENERIC COMPRESSION CLAMP DETAIL

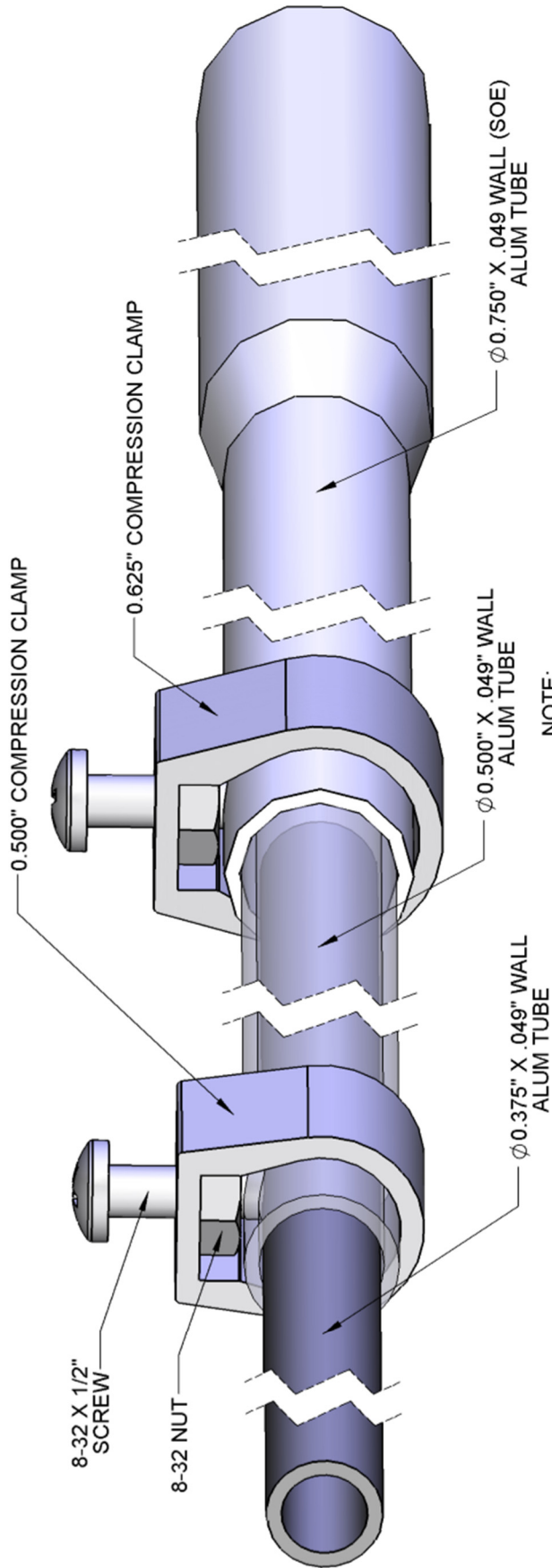

NOTE:
TUBES SHOWN TRANSPARENT
TO SHOW MORE DETAIL

NOTE:
Generic layout to show
how compression clamps work.
Your antenna may have one or the other
or may even have both compression
clamp sizes.

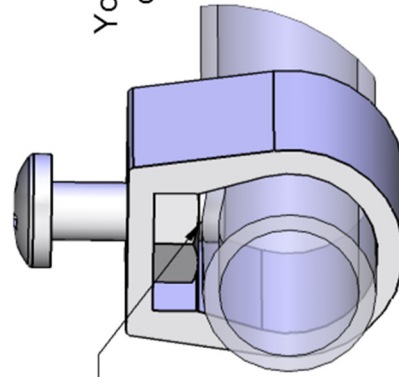

NOTE:
8-32 X 1/2" SCREW
PRESSES ON INNER TUBE

NOTE: INSIDE TUBE NOT SHOWN FOR CLARITY

11M5DX PARTS & HARDWARE

DESCRIPTION	QTY
BOOM SECTION #1: 2" X .065 X 84" SOE	1
BOOM SECTION #2 & #3: 2" X .065 X 84" SOE	2
BOOM SECTION #4: 2" X .065 X 80"	1
D.E. ELEMENT SECTION #1: 1" X .058 X 12" SOE	2
D.E. ELEMENT SECTION #2: 3/4" X .049 X 60" SOE	2
ELEMENT SECTION #1: 3/4" X .049 X 60" SOE (W/ONE HOLE)	8
ELEMENT TIP SECTIONS, 1/2" X .049 X SEE CUT LIST	10
ELEMENT SLEEVE, 7/8" X 15"	4
HAIRPIN TUBE, 24"	2
FIBERGLASS ROD, 7/8" X 15"	1
RING CLAMP, 2"	5
3/8" CLAMP BLOCK, 1" X 1-1/4"	4
BALUN, 1:1, 3-30MHz	1
BALUN STRAP	2
BALUN MOUNTING PLATE, 2" X 4" X 1/8"	1
SHORTING BAR, 1/2" X 1/2" X 5"	1
POLY DISC, 2"OD WITH 7/8" HOLE	2
BAND CLAMP, 2-1/2" with hole	1
SPACER, 3/8" X 1"	1
BOOM TO MAST PLATE, 4" X 6" X 3/16"	1
TURNBUCKLE PLATE, 2" X 4" X 1/4"	1
TURNBUCKLE, 5/16"	2
DACRON ROPE, 5/16" X 25'	1
NYLON TIE, 11" (LARGE BLACK)	6
ZINC PASTE, 1 oz. CUP	1
ASSEMBLY MANUAL	1

HARDWARE:

COMPRESSION CLAMP, 5/8"	10
U-BOLT AND CRADLE, 2.5"	1
U-BOLT AND CRADLE, 2"	5
EYEBOLT, 5/16-18 X 4", ZINC	2
LOCKWASHER, 5/16, SS	14
NUT, 5/16-18, SS	14
BOLT, 1/4-20 X 2-1/2", SS	6
BOLT, 1/4-20 X 2", SS	5
BOLT, 1/4-20 X 1-3/4", SS	8
BOLT, 1/4-20 X 1", SS	5
SET SCREW, 1/4-20 X 1/4", SS	2
LOCKNUT, 1/4-20, SS	24
SCREW, 8-32 X 1-1/4", SS	4
SCREW, 8-32 X 1/2", SS	10
NUT, 8-32, SS	10
LOCKNUT, 8-32, SS	4
ALLEN WRENCH, 1/8"	1

M² ANTENNA SYSTEMS, INC.

4402 N. SELLAND AVE.

FRESNO, CA 93722

(559) 432-8873 FAX: 432-3059

www.m2inc.com Email: sales@m2inc.com