

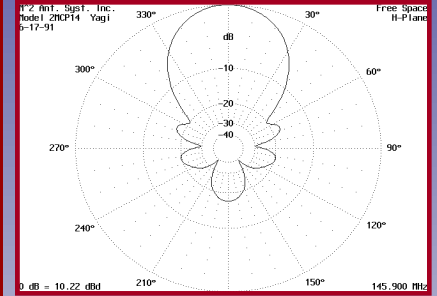

M2 Antenna Systems, Inc.

Model No: 2MCP14

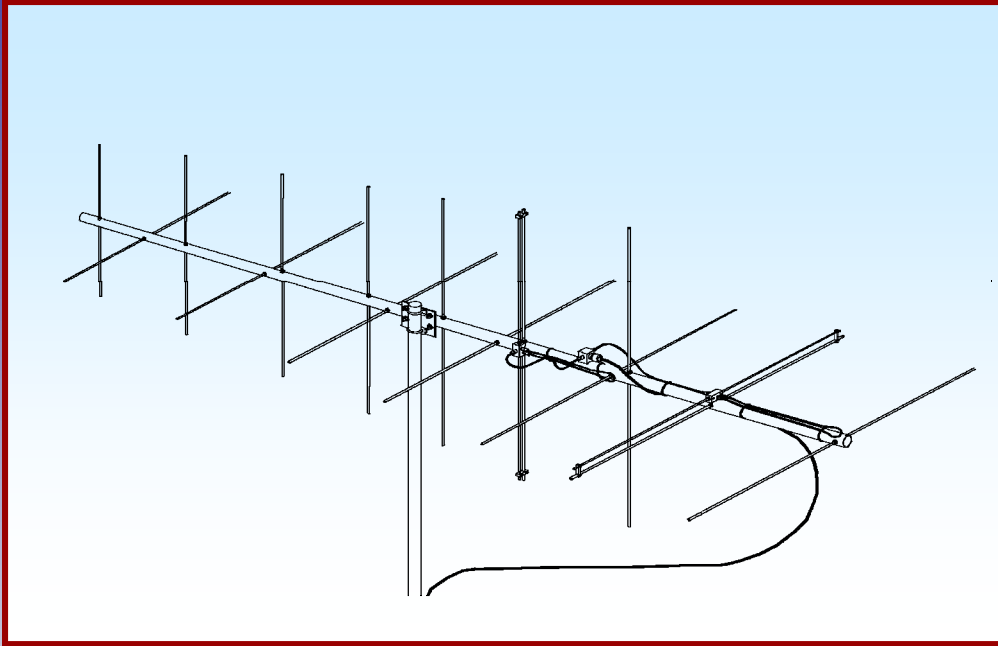

SPECIFICATIONS:

Model	2MCP14	Input Connector	"N" Female
Frequency Range.....	143 To 148 MHz	Power Handling	1.5 kW (250W PS-I)
*Gain	12.34 dBi	Boom Length / Dia.....	10' 6" / 1"
Front to back	20 dB Typical	Maximum Element Length.....	40-1/8"
Beamwidth	52° Circular	Turning Radius:	75-5/8"
Ellipticity	>3dB	Stacking Distance.....	8' High & 8' Wide
Feed type	Folded Dipole	Mast Size.....	1-1/2" to 2" Nom.
Feed Impedance.....	50 Ohms Unbalanced	Wind area / Survival	1.1 Sq. Ft. / 100MPH
Maximum VSWR.....	1.3:1 Typical	Weight / Ship Wt.....	6 Lbs. / 8 Lbs.

***Subtract 2.14 from dBi for dBd**

FEATURES:

The 2MCP14 is a light, medium performance circularly polarized antenna designed to work across the two meter amateur band. Optimum match and gain are between 144 & 147 MHz for the satellite band. Computer design techniques help keep spurious side lobes low down for optimum signal to noise ratios. This antenna features the same CNC machined, O-ring and silicone-gel sealed, driven element assemblies common to all M² Yagi antennas. This insures years of trouble free performance regardless of weather.

Optional items include a heavy duty fiberglass 2" O.D. x 1/4" wall boom with a 1-1/2" solid alum center section to fit through the Yaesu 5400 and 5600 series az-el rotator (model HDFG boom kit), 2M2PORT power divider and vhf-50-2MCP14-2 phasing lines. We also can provide 'H' frames and larger rotators, OR-2800DC (az) and MT-1000 (el). A 136R-14C and a 149T-14C model are also available for the ATS satellite users. Higher gain antennas with 22 elements are also available for all VHF satellite frequencies.

2MCP14 ASSEMBLY MANUAL

TOOL REQUIRED FOR ASSEMBLY: screwdriver, 11/32 nut driver or wrench, 7/16" and 1/2" end wrenches and sockets, measuring tape.

1. Start by laying out the boom sections using the DIMENSION SHEET as a guide. Use 8-32 X 1-1/4 screws and locknuts to join sections. Sections may may be swaged to each other or use 7/8" internal splice sections.

Note: If mounting antenna to a standard H-frame with a T-brace kit, it is important to install the T-brace coupling bars to antenna before elements. Refer to H-Frame and T-brace drawings for placement and more information.

ASSEMBLING THE HORIZONTAL ELEMENTS

2. Separate elements by length into two identical sets, "H" and "V". Lay out the "H" elements by length and position as shown the DIMENSION sheet. Start with the reflector (longest) element. Balance it on your finger to find rough center and push on a black button insulator to about 1/2" off center. Push the element through the holes 1/2" from the rear of the boom and install the second button, snugging it up into boom. **DO NOT BOTHER ACCURATELY CENTERING** the element at this time and **DO NOT INSTALL** the stainless steel shaft retainers yet. It is easier to do it after all the horizontal elements are installed in the boom.
3. Install the 3/16" rod DRIVEN ELEMENT as you did the reflector. Then continue with the installation of the DIRECTORS. **Note that the Director Elements do not consistently diminish in length from rear to front, so pay close attention to length and position.**
4. Now begin centering the elements. Use a tape measure to EQUALIZE the amount the element sticking out on each side of the boom. Once you have all the elements centered, sight down the element tips from the rear comparing each side. Look for any obvious discrepancies and correct if found.

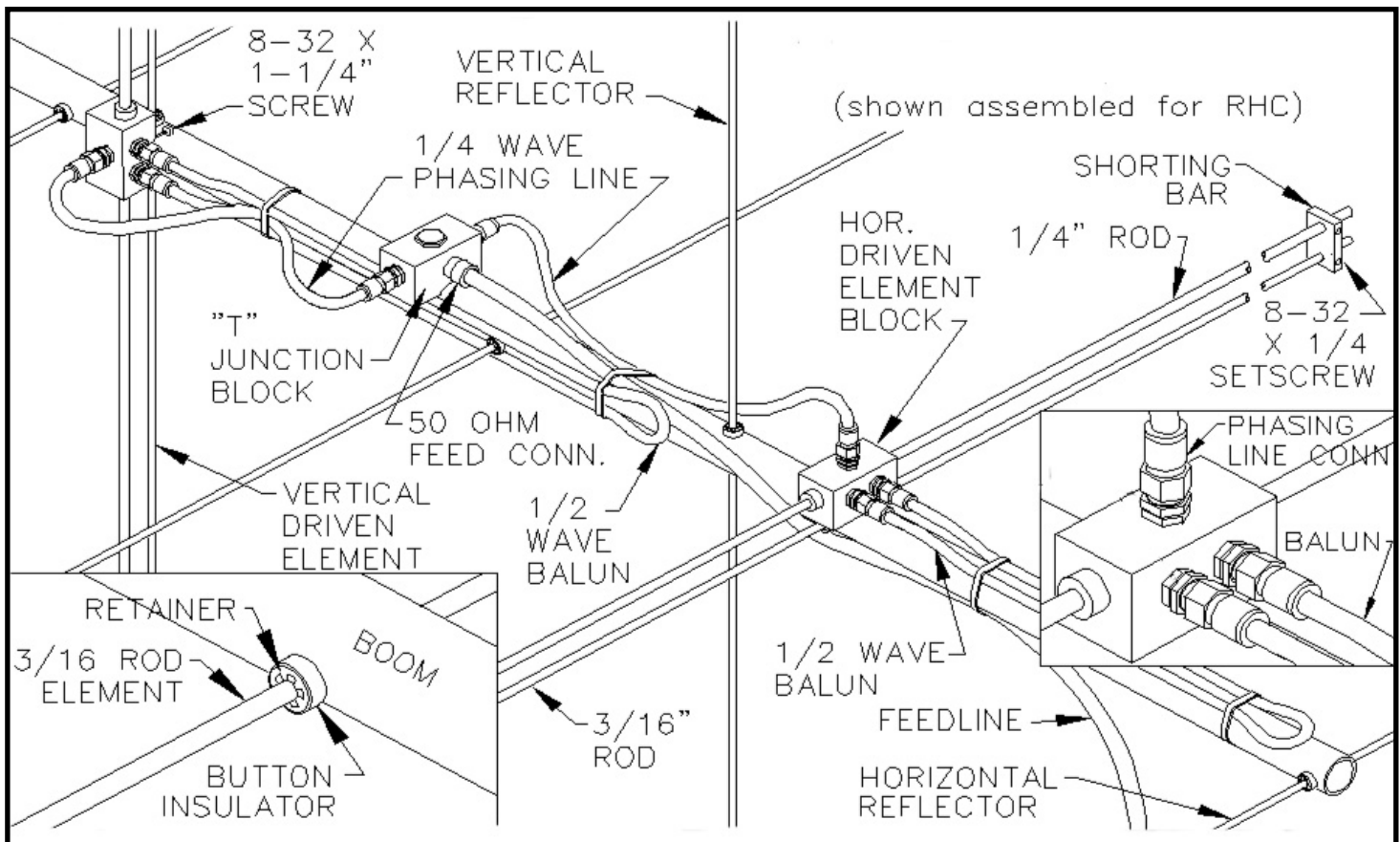

2MCP14 ASSEMBLY MANUAL

5. NOTE: The SHAFT RETAINERS, for securing the elements, should always be used for permanent and long term antenna installations. For portable or temporary use the retainers may be left off. The button insulators, normally a tight fit, hold the elements quite securely. To install the stainless steel SHAFT RETAINERS, use thumb and forefinger to hold the retainer over the end of the PUSH TUBE (3/8" x 3" tube, supplied in the kit), internal fingers on retainer dished into tube. HOLD THE ELEMENT FIRMLY TO PREVENT IT FROM SLIDING OFF CENTER and press the retainer onto the element end and continue until retainer butts on insulator button. Locking pliers, *lightly* clamped up against opposite button insulator will help maintain center reference. If you push the first retainer too far, remove element from boom, push retainer completely off the element, and start over. Install another retainer to the opposite side of the element. Continue installing retainers until all elements are locked in place.
6. Mount the **HORIZONTAL DRIVEN ELEMENT BLOCK / ROD ASSEMBLY** to the **TOP** of the boom using a single 8-32 X 1-1/4" screw. Orient the block with the two balun connectors facing to rear. Install the 8-32 x 1/4" set screws (internal Allen head - tool supplied) into the SHORTING BARS. Slide the bars onto the Driven Element Block Rods and the driven element rods. Position the Shorting Bars flush with the ends of the 3/16" rod that passes through the boom. Align the bars with each other and tighten the set screws.
7. Mount the "T" JUNCTION BOX to either side of the boom using the small hole forward of the vertical reflector. Secure with 8-32 x 1-1/4" screw.

ASSEMBLING THE VERTICAL ELEMENTS

8. Repeat steps #2 through #5 for the Vertical elements, using the Dimension Sheet as your guide to lengths and spacing.
9. **NOTE: INSTALLATION OF THE VERTICAL DRIVEN ELEMENT BLOCK DETERMINES THE CIRCULARITY OF THIS ANTENNA. THE ORIENTATION OF THE BLOCK FOR RHC - RIGHT HAND CIRCULARITY - IS SHOWN ON THE DIMENSION SHEET.**
Viewed from the rear of the boom (rearmost Reflector HORIZONTAL), the VERTICAL Driven Element Block mounts to the LEFT hand side of the boom with the two Balun connectors oriented to the REAR. Secure with 8-32 x 1-1/4" screw. Install the Shorting Bars as in step #6.
10. Attach Baluns and Phasing lines to the Driven Element Blocks and Junction Block as shown on the DETAILED DRAWING. Depending on model and polarity, the Vertical balun may loop around another element. This is normal. Coil rear balun if single loop overhangs rear of boom. Form balun and phasing line coax close to the boom and secure with nylon cable ties. Ties should be snug but not crushing or kinking the coax. Tighten the connectors *gently* using a 7/16" end wrench. A lot of torque is unnecessary.

2MCP14 ASSEMBLY MANUAL

11. Use good quality coax and "N" connector for your feedline. Secure feed coax near connector on Junction Block, to provide stress relief, route to rear of boom, and secure again. Allow about 60" of coax to hang in a loop between the rear end of the boom and the reattachment point (at least 12" beyond element tips) on the mast or crossboom. ***Do not route feedline to boom to mast plate as exiting antenna here will adversely affect circular field.***
12. The boom to mast plate is normally mounted to the boom at the balance point (with feedline attached). Use two 1" U-bolts and the stainless nuts and lock washers provided. DO NOT OVER TIGHTEN. 2" U-bolts are provided for mounting the antenna to your NON-CONDUCTIVE 2" mast or crossboom.

INSTALLATION TIPS

13. The 2M14CP is a circular polarized antenna and creates a field in all planes or polarities. Performance DETERIORATES SIGNIFICANTLY if it is mounted on a metal (conductive) mast or crossboom. A 2" mast or crossboom of any NON-CONDUCTIVE material can be used. Fiberglass is the prime choice for its strength and weather resistance. Mount the 2M14CP so that element tips are at least 12" from any conductive material (mast, tower, feedline, etc.).

THIS COMPLETES THE ANTENNA ASSEMBLY.

Carefully manufactured by:

M² ANTENNA SYSTEMS, INC.

4402 N. Selland Ave.

Fresno, CA 93722

(559) 432-8873 Fax: 432-3059

www.m2inc.com Email: sales@m2inc.com

2MCP14 DIMENSION SHEET (INCHES)

ELEMENT SPACING

HORIZONTAL

0
.500

10.375

15.750

VERTICAL

20.000

NOTE:
RIGHT HAND
CIRCULARITY SHOWN.

28.437

29.687

35.250

47.937

50.125

54.00
BTM ϕ

69.625

77.875

97.375

105.375

124.875

125.500

ELEMENT LENGTH

HORIZONTAL

40.125

18.500
SHORTING BAR

39.5

37.062

VERTICAL

40.125

37.188

39.5

37.062

37.188

36.375

36.375

35.437

35.437

34.875

34.875

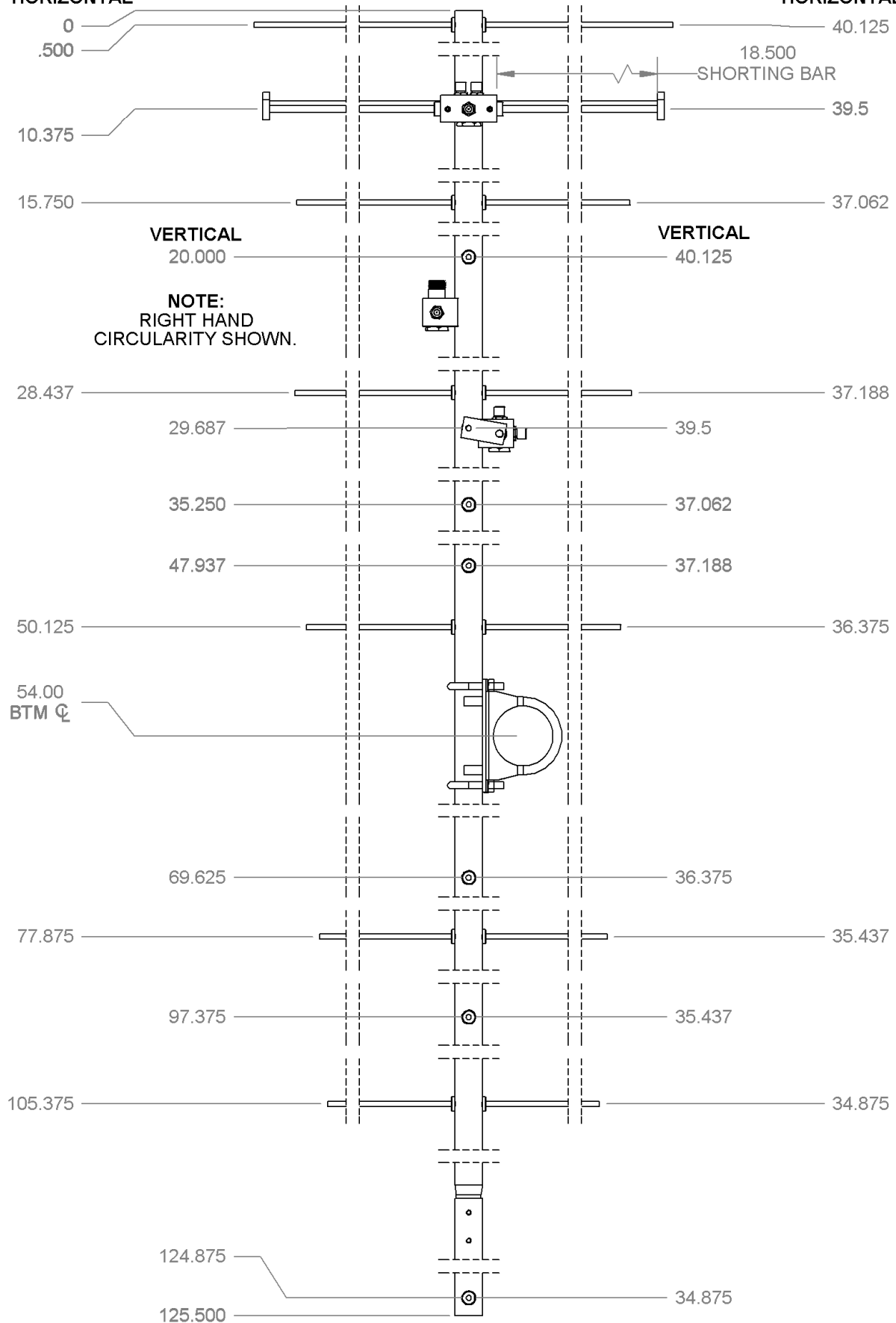

2MCP14 DIMENSION SHEET (CENTIMETERS)

ELEMENT SPACING
HORIZONTAL

2MCP14 DIMENSIONS
(DIMENSIONS IN CENTIMETERS)

ELEMENT LENGTH
HORIZONTAL

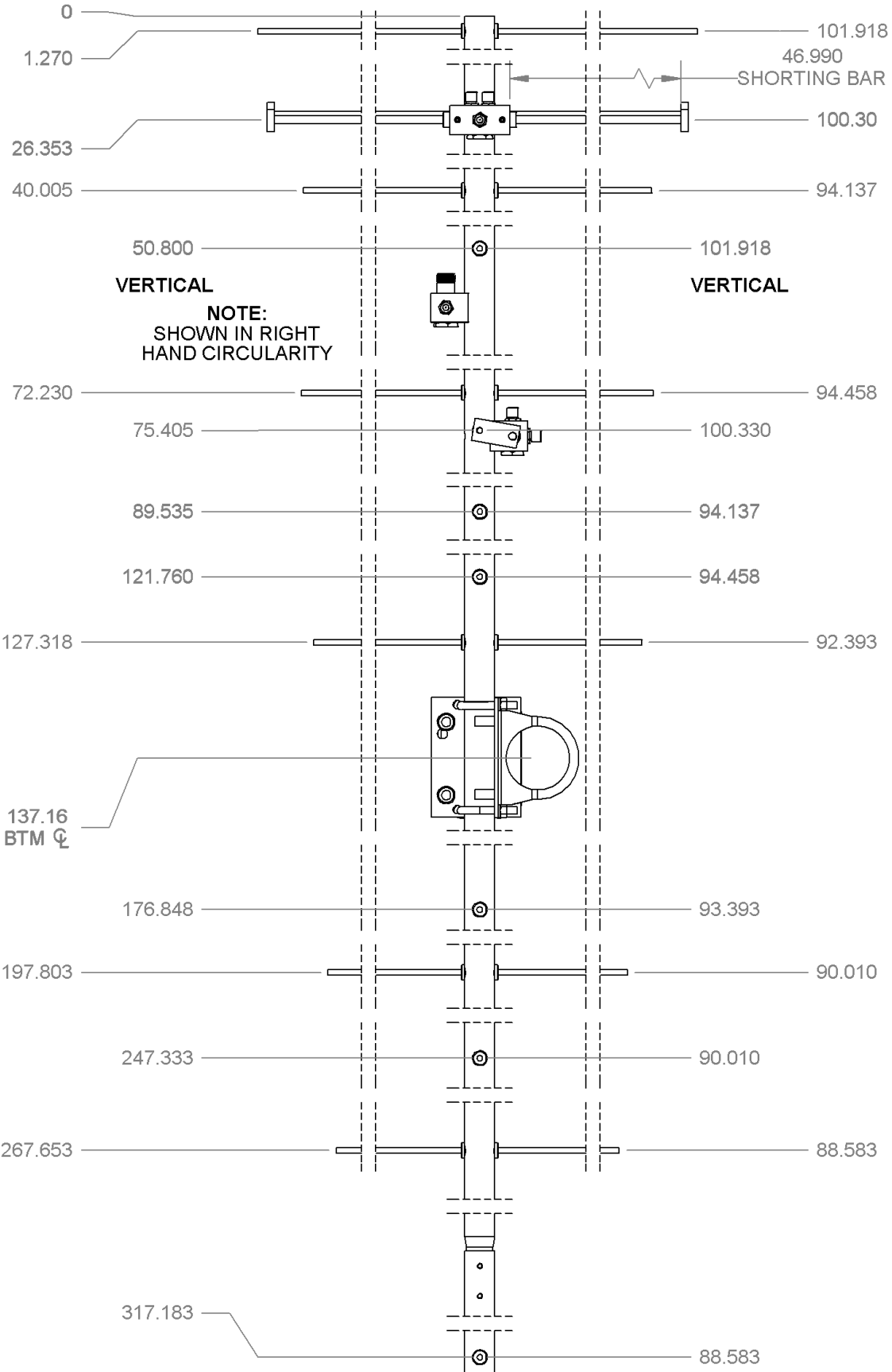

REF. 318.770

2MCP14 PARTS & HARDWARE

DESCRIPTION	QTY
BOOM SECTION, 1 X .058 X 60" SOE	2
BOOM SECTION, 1 X .058 X 11-1/2"	1
ELEMENTS, 3/16 ROD X Dimension Sheet.....	14
DRIVEN ELEMENT BLOCK ASSEMBLY.....	2
JUNCTION BLOCK.....	1
BALUN, RG-6 1/2λ	2
MATCHING / PHASING CABLE, 1/4λ	2
BOOM-TO-MAST PLATE, .125 X 3 X 4"	1
U-BOLT AND CRADLE, 2"	2
U-BOLT, 1".....	2
ASSEMBLY MANUAL.....	1

IN HARDWARE BAG:

SHORTING BAR.....	4
BUTTON INSULATORS	28
KEEPER, SS.....	28
NUT, 5/16-18 SS.....	4
LOCKWASHER, 5/16 SS.....	4
NUT, 1/4-20 SS.....	4
LOCKWASHER, 1/4 SS.....	4
SCREW, 8-32 X 1-1/4 SS	7
LOCKNUT, 8-32 SS.....	4
SET SCREW, 8-32 X 1/4 SS	8
CABLE TIE, NYLON	6
ALLEN HEAD WRENCH	1
PUSH TUBE, 3/8 X 3".....	1

M² ANTENNA SYSTEMS, INC.

4402 N. Selland Ave.

Fresno, CA 93722

(559) 432-8873 Fax: 432-3059

www.m2inc.com Email: sales@m2inc.com