

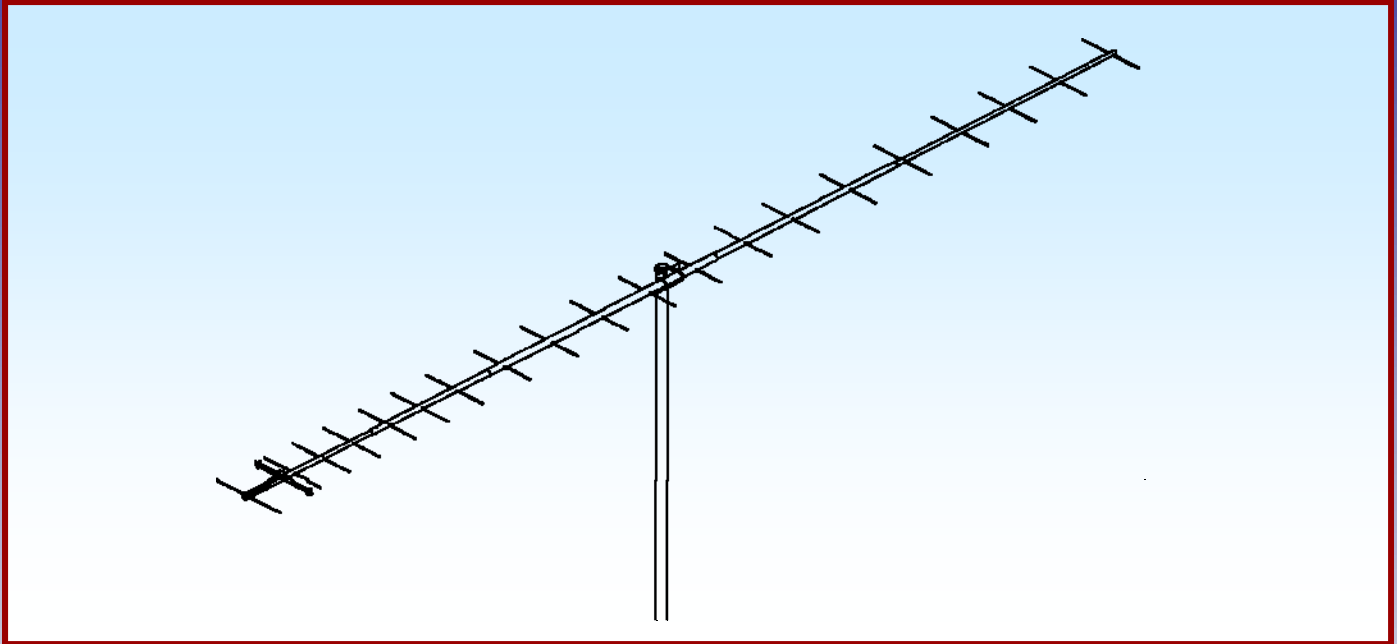

M2 Antenna Systems, Inc. Model No: 432-6WL



SPECIFICATIONS:

Model	432-6WL	Power Handling	1 kW
Frequency Range.....	420 To 440 MHz	Boom Length / Dia.....	14' 6" / 1"
*Gain	18.04 dBi	Maximum Element Length.....	13-7/8"
Front to back	23 dB Typical	Turning Radius:	96"
Beamwidth	E=22° H=24°	Stacking Distance.....	65" High & 65" Wide
Feed type	Folded Dipole	Mast Size.....	2" Nom.
Feed Impedance.	50 Ohms Unbalanced	Wind area / Survival	0.85 Sq. Ft. / 100 MPH
Maximum VSWR.....	1.2:1 Typical	Weight / Ship Wt.....	4.6 Lbs. / 7 Lbs.
Input Connector.....	"N" Female		

***Subtract 2.14 from dBi for dBd**

FEATURES:

The 432-6WL is the ultimate antenna: computer and range optimized for very high gain and excellent pattern across its bandwidth. It can be mounted vertically or horizontally and is also ideal for OSCAR, FM, LONG HAUL TROPO, ETC. Its lightweight, yet sturdy, construction keeps the wind area low without compromising the 100 MPH wind survival rating. We guarantee you will be impressed.

The heart of the 432-6WL is a unique Driven Element Module with superior weather resistance and power handling abilities. The module is CNC machined from a solid aluminum block, features O-ring sealed connectors and internal connections embedded in a special silicone gel that seals out weather and improves power handling. The Balun connectors are triple-sealed to the coax. Other key mechanical and electrical parts are CNC machined from 6061-T6 aluminum and all hardware except U-bolts is stainless steel.

The 432-6WL offers you uncompromising performance, enduring mechanical construction, and long term electrical integrity. Where else but M².

432-6WL ASSEMBLY MANUAL

TYPICAL TOOLS REQUIRED: measuring tape, std slot or phillips screwdriver, 11/32, 7/16, and 1/2 spin-tite, end wrenches and / or sockets.

1. Lay out the boom sections and assemble using the DIMENSION sheet as a guide for position and hardware.
2. Lay out the elements by length and position as shown the DIMENSION sheet. Find rough center of the reflector (longest) element by balancing it across finger. Push on a black button insulator to about 1/2" from center. Insert the element through the holes at the rear of the boom and install the second button. Install the 3/16" rod DRIVEN ELEMENT as you did the reflector. Then continue with the installation of the DIRECTORS. **Note that the Director Elements may not consistently diminish in length from rear to front, so pay close attention to length and position specified on Dimension Sheet.**
3. Now begin centering the elements. Use a tape measure to EQUALIZE the amount the element sticking out on each side of the boom. Once all are centered, sight down the antenna from the rear and compare tip symmetry. Look for any obvious discrepancies and correct if found.
4. Stainless steel SHAFT RETAINERS are used for securing the elements and insulators. Always use for permanent and long term antenna installations. For most portable or temporary use, the button insulators are satisfactory and the retainers may be left off.
5. Use thumb and index finger to hold a Shaft Retainer over end of the 3/8 x 3" push tube (internal fingers dished into tube). Hold the element firmly and start the keeper onto the rod by applying pressure with the push tube. Push the Shaft Retainer down element until tight against the button insulator (Locking pliers, **lightly** clamped up against opposite button insulator will help maintain center reference and keep you from pushing the first Shaft Retainer too far). Repeat

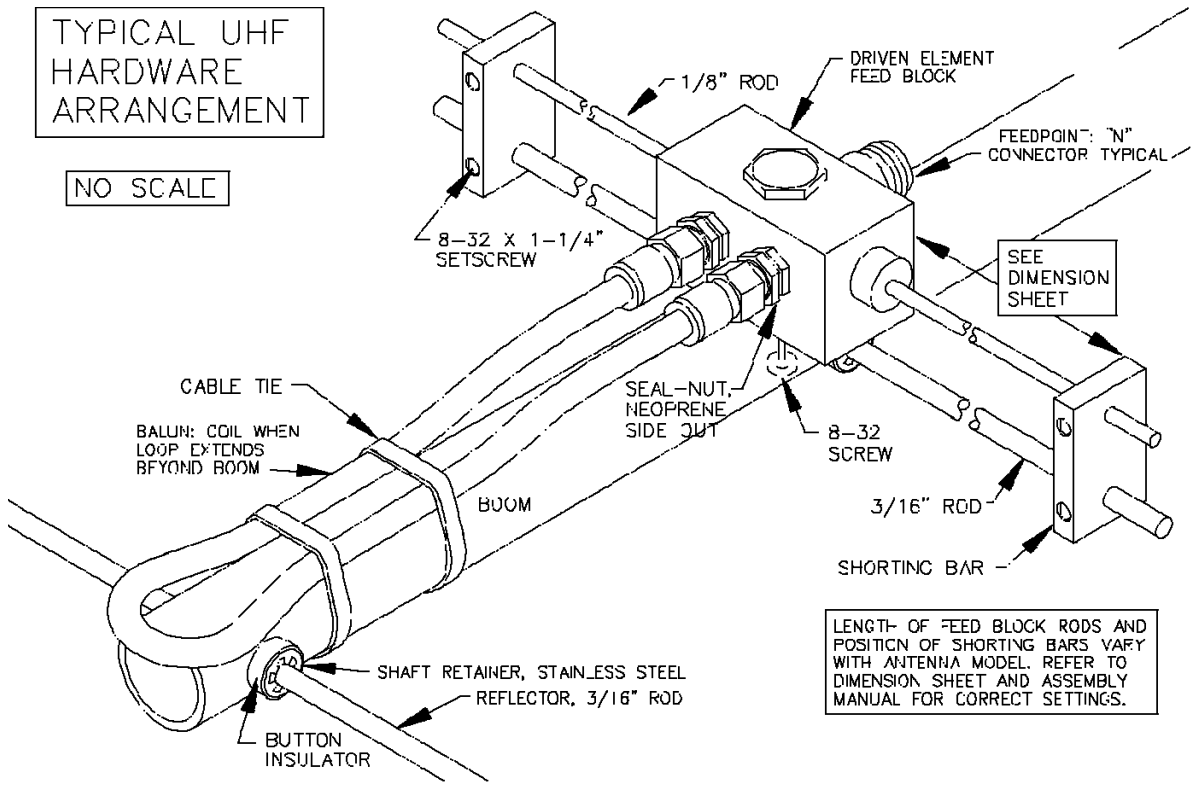
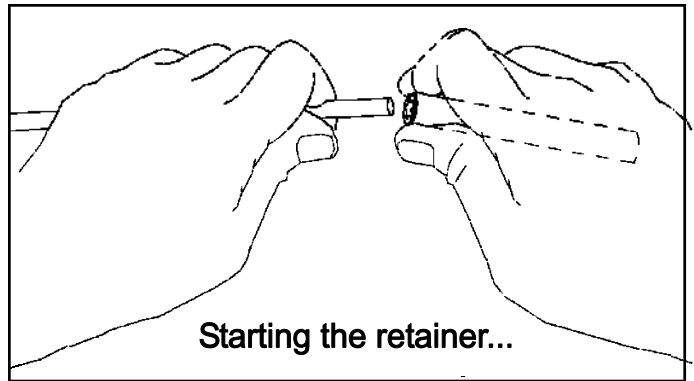

432-6WL ASSEMBLY MANUAL

for the opposite side. Continue installing Shaft Retainers until all elements are locked in place.

6. Mount the DRIVEN ELEMENT FEED BLOCK to the boom using a single 8-32 screw 1/4" longer than the boom diameter. Orient with feed and balun connectors oriented as shown on the Dimension Sheet.
7. Thread a 3/8" SEAL-NUT fully onto each balun connector on the feed block, with black Neoprene side facing out. Generally the balun is installed in one long loop. Rear mounted baluns may be coiled once if length extends beyond boom. Attach balun to the block connectors and tighten **gently** using a 7/16" end wrench. Then back the Seal Nuts out and finger-tighten firmly up against the face of the connectors (or tighten **gently** with 1/2" end wrench). Form the balun coax close to the boom and secure with cable ties (snug but not crushing or kinking the coax).
8. Install the 8-32 x 1/4" set screws (internal Allen head - tool supplied) into the SHORTING BARS. Slide the bars onto the 3/16" rod driven element tips and the 1/4" Feed Block Rods. Position the Shorting Bars as specified on the DIMENSION SHEET: the distance given is between the outer face of the Feed Block and the inner face of the Shorting Bar. Align the bars and rods with each other and tighten the setscrews.
9. For center mounted antennas, the boom to mast plate is normally mounted as close as possible to the balance point (with feedline or a temporary equivalent attached). For rear mounted antennas, use the boom length provided behind the reflector element. Keep mounting plate at least 1" from any element. Secure plate with two U-bolts and the stainless nuts and lock washers provided. DO NOT OVER TIGHTEN. Additional U-bolts and stainless nuts / lockwashers are provided for mounting the antenna to your mast. THIS COMPLETES THE ANTENNA ASSEMBLY.
10. For optimum performance, mount antenna high and in the clear. **Always** use high quality coax and connectors. Old, corroded, or poor quality materials can SERIOUSLY affect VSWR, gain, and pattern. If possible, test the antenna, connectors and feedline BEFORE installation. At 6' in height, the antenna will exhibit performance **approaching** the specifications. If it doesn't, check feedline and connectors for continuity and shorts. Check antenna shorting bars, element placement and length, against Dimension Sheet.

11. MOUNTING AND STACKING INFORMATION

Rear mounted antennas can generally be mounted in any polarization to any type of mast, conductive or non-conductive.

Center mounted antennas can also be mounted in any polarity. **However, a mast or crossboom in-line (parallel) with the element plane must be non-conductive.** Anything conductive in the element plane will disrupt the pattern and reduce performance (even the feedline). When a non-conductive mast or crossboom is in-line with elements, route feedline away at right angles to the elements and reattach at least 6" beyond element tips. Fiberglass is the recommended material for a non-conductive mast or crossboom because of its strength and weather resistance.

Stacking: See the Dimension Sheet for stacking separation dimensions.

1. All driven element blocks MUST be oriented to the same side of boom.
2. All boom-to-mast plates MUST be mounted at the same point on the boom.
3. Feed / phasing lines MUST be of equal electrical length or, ideally, multiples of 1 wavelength in order to maintain equal phasing in the array.

Carefully manufactured by:

M² ANTENNA SYSTEMS, INC.

4402 N. Selland Ave.

Fresno, CA 93722

(559) 432-8873 Fax: 432-3059

www.m2inc.com Email: sales@m2inc.com

432-6WL DIMENSION SHEET

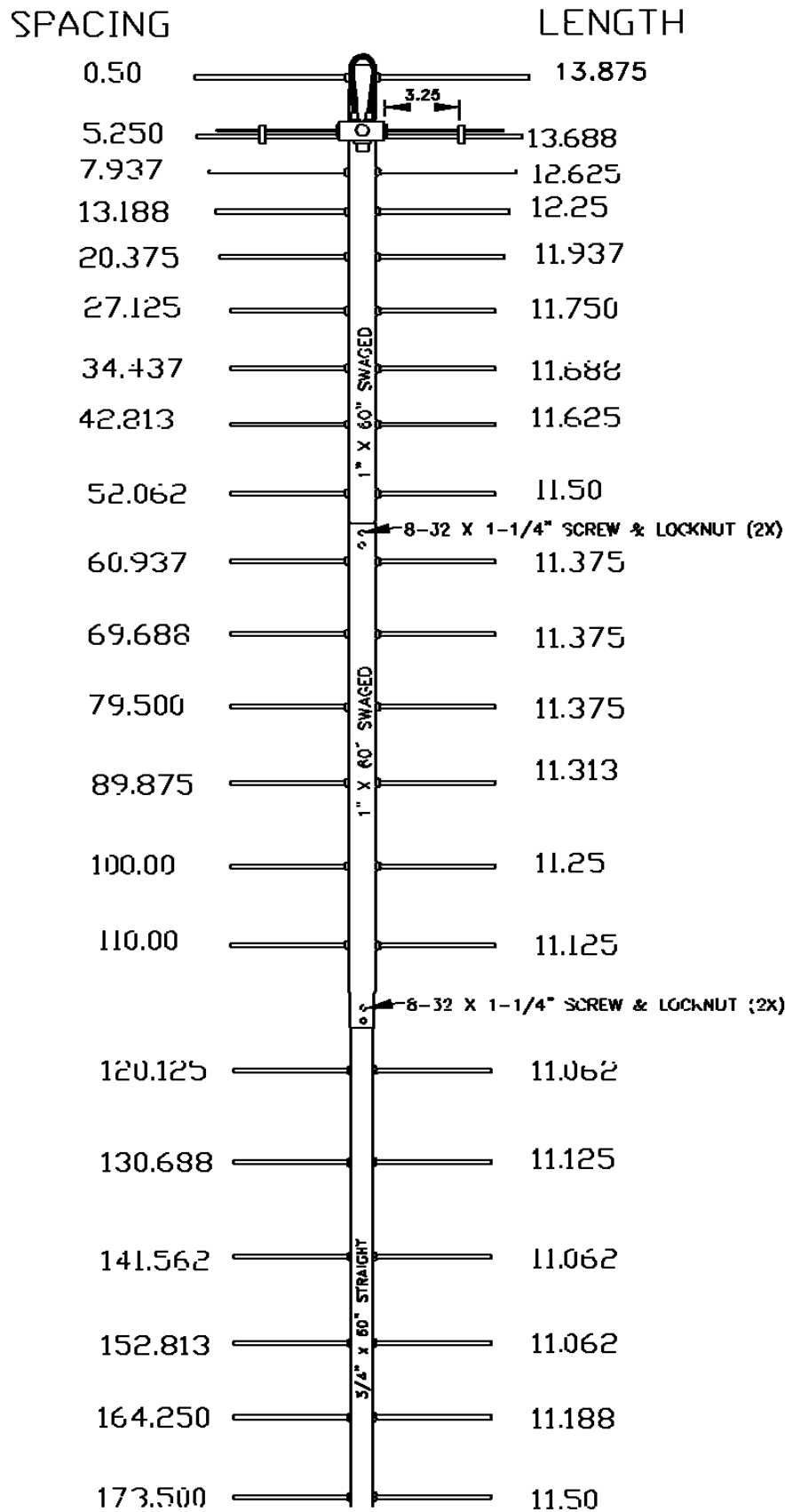

DECIMAL TO FRACTION CONVERSION	
.062	= 1/16
.125	= 1/8
.188	= 3/16
.250	= 1/4
.313	= 5/16
.375	= 3/8
.437	= 7/16
.500	= 1/2
.562	= 9/16
.625	= 5/8
.688	= 11/16
.750	= 3/4
.813	= 13/16
.875	= 7/8
.937	= 15/16

432-6WL PARTS & HARDWARE

DESCRIPTION.....	QTY
BOOM SECTION, 1 X .058 X 60 SOE.....	2
BOOM SECTION, 1 X .058 X 60 STR.....	1
ELEMENTS, 3/16 ROD x Dimension Sheet	21
FEED BLOCK,	1
BALUN, RG-6 1/2 l.....	1
BOOM-TO-MAST PLATE, 3 X 4 X .188"	1
U-BOLT AND CRADLE, 2"	2
U-BOLT, 1"	2
ASSEMBLY MANUAL.....	1

IN HARDWARE BAG:

BUTTON INSULATORS	42
SHAFT RETAINER, SS	42
NUT, 5/16-18 SS.....	4
LOCKWASHER, 5/16 SS.....	4
NUT, 1/4-20 SS.....	4
LOCKWASHERS, 1/4 SS	4
SCREW, 8-32 X 1-1/4 SS	5
LOCKNUT, 8-32 SS	4
SHORTING BAR.....	2
SETSCREW, 8-32 X 1/4, SS	4
CABLE TIE, NYLON	4
SEAL NUTS, 3/8-32	2
ALLEN HEAD WRENCH, 5/64"	1
PUSH TUBE, 3/8 X 3"	1

M² ANTENNA SYSTEMS, INC.

4402 N. Selland Ave.

Fresno, CA 93722

(559) 432-8873 Fax: 432-3059

www.m2inc.com Email: sales@m2inc.com