

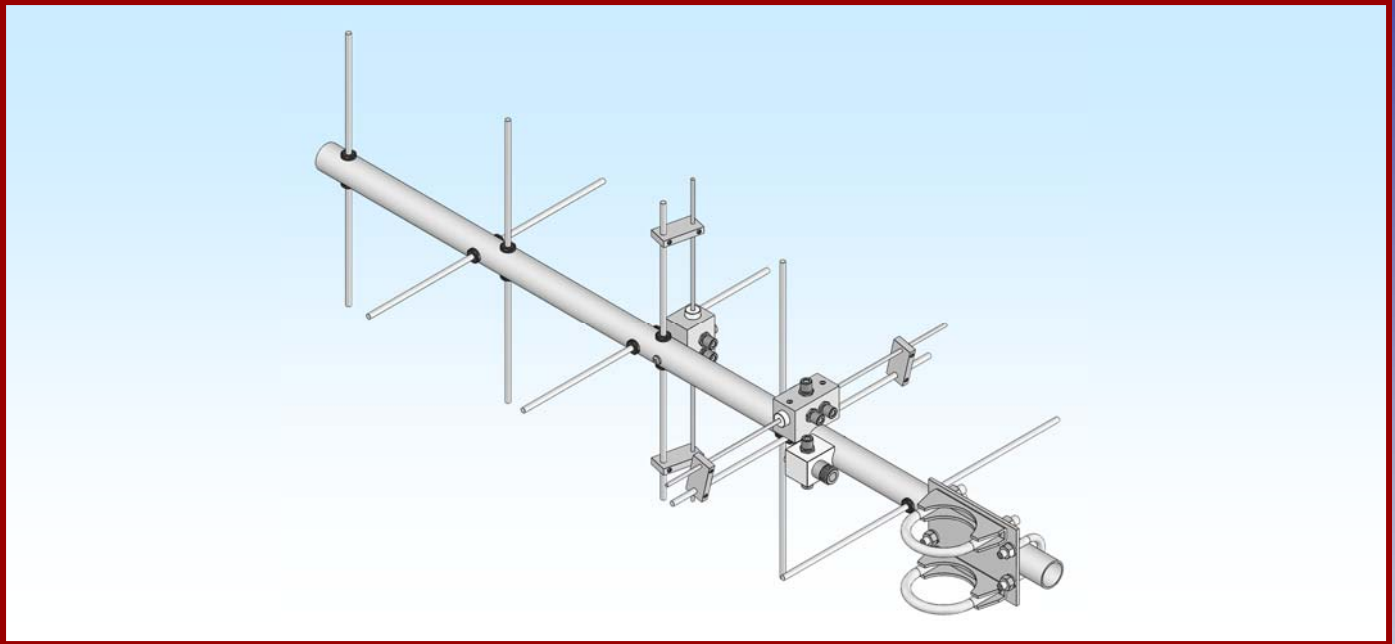

M2 Antenna Systems, Inc. Model No: 466CP8



SPECIFICATIONS:

Model	466CP8	Input Connector	"N" Female others opt.
Frequency Range.....	462 To 470 mHz	Power Handling	600 Watts
*Gain	10.2 dBic	Boom Length / Dia.....	33" / 1"
Front to back	18 dB Typical	Maximum Element Length.....	12-1/2"
Ellipticity	1.5 dB Typical	Turning Radius:	31"
Beamwidth	70° Circular	Stacking Distance.....	Call Factory
Feed type	Folded Dipole	Mast Size.....	1-1/2" to 2" Nom.
Feed Impedance.	50 Ohms Unbalanced	Wind area / Survival	1 Sq. Ft. / 100MPH
Maximum VSWR.....	1.5:1 Max	Weight / Ship Wt.....	3 Lbs. / 6 Lbs.

***Subtract 2.14 from dBi for dBd**

FEATURES:

The 466CP8 is a practical sized, yet high performance circular polarized antenna with a remarkably clean pattern. The pattern is important in order to match the antenna's noise temperature with modern low noise preamps. This antenna is ideal for satellite work but is also excellent for terrestrial uses like ATV, repeater operation, and long haul tropo DX.

The CNC machined driven element module is O-ring sealed and weather tight for low maintenance and long-term peak performance. Internal connected are encapsulated in a space-age silicone gel that seals out moisture and improves power handling. The 3/16" 6061-T6 rod elements are centered to minimize interaction and maintain good ellipticity. Insulators are UV stabilized and locked in place with stainless keepers. Rugged construction, uncompromising performance for the boomlength: thats the M² 466CP8!

466CP8 ANTENNA MANUAL

TOOL REQUIRED FOR ASSEMBLY: screwdriver, 11/32 nut driver or wrench, 7/16" and 1/2" socket or end wrenches, measuring tape.

Note: If mounting antenna to a standard H-frame with a T-brace kit, it is important to install the T-brace coupling bars to antenna before elements. Refer to H-Frame and T-brace drawings for placement and more information.

ASSEMBLING THE HORIZONTAL ELEMENTS

1. Lay out the elements by "H" length and position as shown the DIMENSION SHEET. Start with the reflector (longest) element. Balance it on your finger to find rough center and push on a black button insulator to about 1/2" off center. Push the element through the holes at the rear of the boom and install the second button, snugging it up into boom. **DO NOT BOTHER CENTERING** the element at this time and **DO NOT INSTALL** the stainless steel shaft retainers yet. It is easier to do it after all the horizontal elements are installed in the boom.
2. Install the 3/16" rod DRIVEN ELEMENT as you did the reflector. Then continue with the installation of the DIRECTORS. **Note that the Director Elements do not consistently diminish in length from rear to front, so pay close attention to length and position.**
3. Now begin centering the elements. Use a tape measure to EQUALIZE the amount the element sticking out on each side of the boom. Once you have all the elements centered, sight down the element tips from the rear comparing each side. Look for any obvious discrepancies and correct if found.

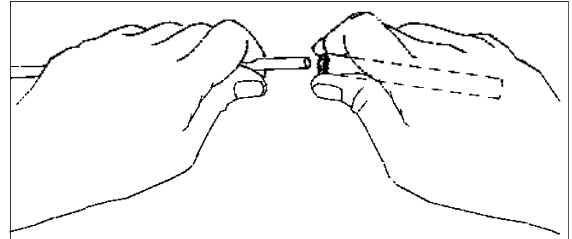

4. Stainless steel SHAFT RETAINERS lock the elements in place. They should always be used for permanent and long term antenna installations. For portable or temporary use, the button insulators are adequate for holding the elements and the retainers may be left off.
To install the stainless steel SHAFT RETAINERS, use thumb and forefinger to hold the retainer over the end of the PUSH TUBE (3/8" x 3" tube, supplied in the kit), internal fingers on retainer dished into tube. **HOLD THE ELEMENT FIRMLY TO PREVENT IT FROM SLIDING OFF CENTER** and press the retainer onto the element end and continue until retainer butts on insulator button. Locking pliers, **lightly** clamped up against opposite button insulator will help maintain center reference (if you push the first retainer too far, remove element from boom, push retainer completely off the element, and start over). Install another retainer to the opposite side of the element. Continue installing retainers until all elements are secured.
5. Mount the **HORIZONTAL DRIVEN ELEMENT BLOCK / ROD ASSEMBLY** to the **TOP** of the boom using a single 8-32 X 1-1/4" screw. Orient the block with the two balun connectors facing to rear.
6. Install the 8-32 x 1/4" set screws (internal Allen head - tool supplied) into the SHORTING BARS. Slide the bars onto the 1/8" Driven Element Block Rods and the 3/16" driven element rod. **Position the Shorting Bars according to dimension sheet.** Align the bars with each other and tighten the set screws.

ASSEMBLING THE VERTICAL ELEMENTS

Note: The vertical element set is shifted forward on the boom by 1/4 wavelength. This increases isolation between element planes, improving circularity and ease of phasing / matching the two element sets.

7. Repeat steps #2 through #5 for the Vertical elements, using the Dimension Sheet as your guide to lengths and spacing.

INSTALLATION OF THE VERTICAL DRIVEN ELEMENT BLOCK DETERMINES THE CIRCULARITY OF THIS ANTENNA. THE ORIENTATION OF THE BLOCK FOR RHC - RIGHT HAND CIRCULARITY, IS SHOWN ON THE DIMENSION SHEET AND DRAWING AND DESCRIBED BELOW:

466CP8 ANTENNA MANUAL

8. Viewed from the rear of the boom (rearmost Reflector HORIZONTAL), the VERTICAL Driven Element Block mounts to the RIGHT hand side of the boom with the two Balun connectors oriented to the REAR. Secure with 8-32 x 1-1/4" screw. Install the Shorting Bars as in step #7.

9. Before installing the Baluns and Matching / Phasing Harness, thread 3/8" SEAL NUTS fully onto all connectors, with the black Neoprene face of the nuts facing out. Attach Baluns and Phasing lines to the Driven Element Blocks and Junction Block as shown on the Dwg (see picture below). Tighten the connectors **gently** using a 7/16" end wrench. Once the connectors are tight, back the Seal Nuts out and finger-tighten firmly up against the face of the connectors (or tighten **gently** with 1/2" end wrench). A lot of torque is unnecessary. Depending on model and polarity, the Vertical balun may loop around another element. This is normal. Form balun coax until it is close to the boom and secure with a nylon cable tie. Also secure the other balun and the matching / phasing harness coax with cable ties. Ties should be snug but not crushing or kinking the coax.

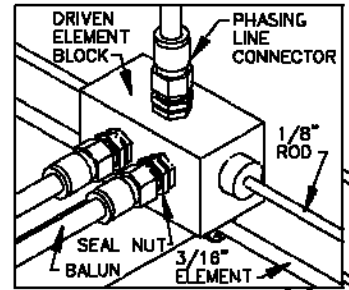

10. Use good quality coax and "N" connector for your feedline (see Installation Tips). Secure feed coax near connector on Junction Block, to provide stress relief. Allow about 60" of coax to hang in a loop between the rear end of the boom and the reattachment point (at least 12" beyond element tips) on the mast or crossboom. **Do not route feedline to boom to mast plate as exiting antenna here will adversely affect circular field.**

11. The boom to mast plate is normally mounted to the boom at the balance point. Since the feed line represents significant weight it is best to have it attached and fastened to the boom with cable ties before final mounting the plate. Use two 1" U-bolts and the stainless nuts and lock washers provided. DO NOT OVER TIGHTEN. 1-1/2" and 2" U-bolts (and stainless steel nuts / lockwashers) are provided for mounting the antenna to your NON-CONDUCTIVE mast or crossboom.

THIS COMPLETES THE ANTENNA ASSEMBLY.

CAREFULLY MANUFACTURED BY:
M² ANTENNA SYSTEMS, INC.

4402 N. SELLAND AVE.
FRESNO, CA 93722

(559) 432-8873 FAX: 432-3059

www.m2inc.com Email: sales@m2inc.com

466CP8 INSTALLATION TIPS

1. The 466CP8 is a circular polarized antenna and creates a field in all planes or polarities. Performance DETERIORATES SIGNIFICANTLY if it is mounted on a metal (conductive) mast or crossboom. A mast or crossboom of any NON-CONDUCTIVE material must be used. Fiberglass is the prime choice for its strength and weather resistance. Mount the 466CP8 so that element tips are at least 12" from any conductive material (mast, tower, feedline, etc.).
2. Recommended feedlines, in order of preference:
 Andrews or Celwave 1/2" hardline
 Times FM-8 or Belden 8214
 Try to keep the cable run to under 100 ft. to prevent excessive signal loss.
3. To maintain proper phasing when stacking two or more antennas, mount each with the same orientation of Driven Element Blocks. DO NOT MOUNT IN MIRROR IMAGE. See the Specification Sheet for stacking distances. For more detailed stacking information contact M².

CAREFULLY MANUFACTURED BY:

M² ANTENNA SYSTEMS, INC.
4402 N. SELLAND AVE.
FRESNO, CA 93722
(559) 432-8873 FAX: 432-3059
www.m2inc.com Email: sales@m2inc.com

466CP8 DIMENSION SHEET

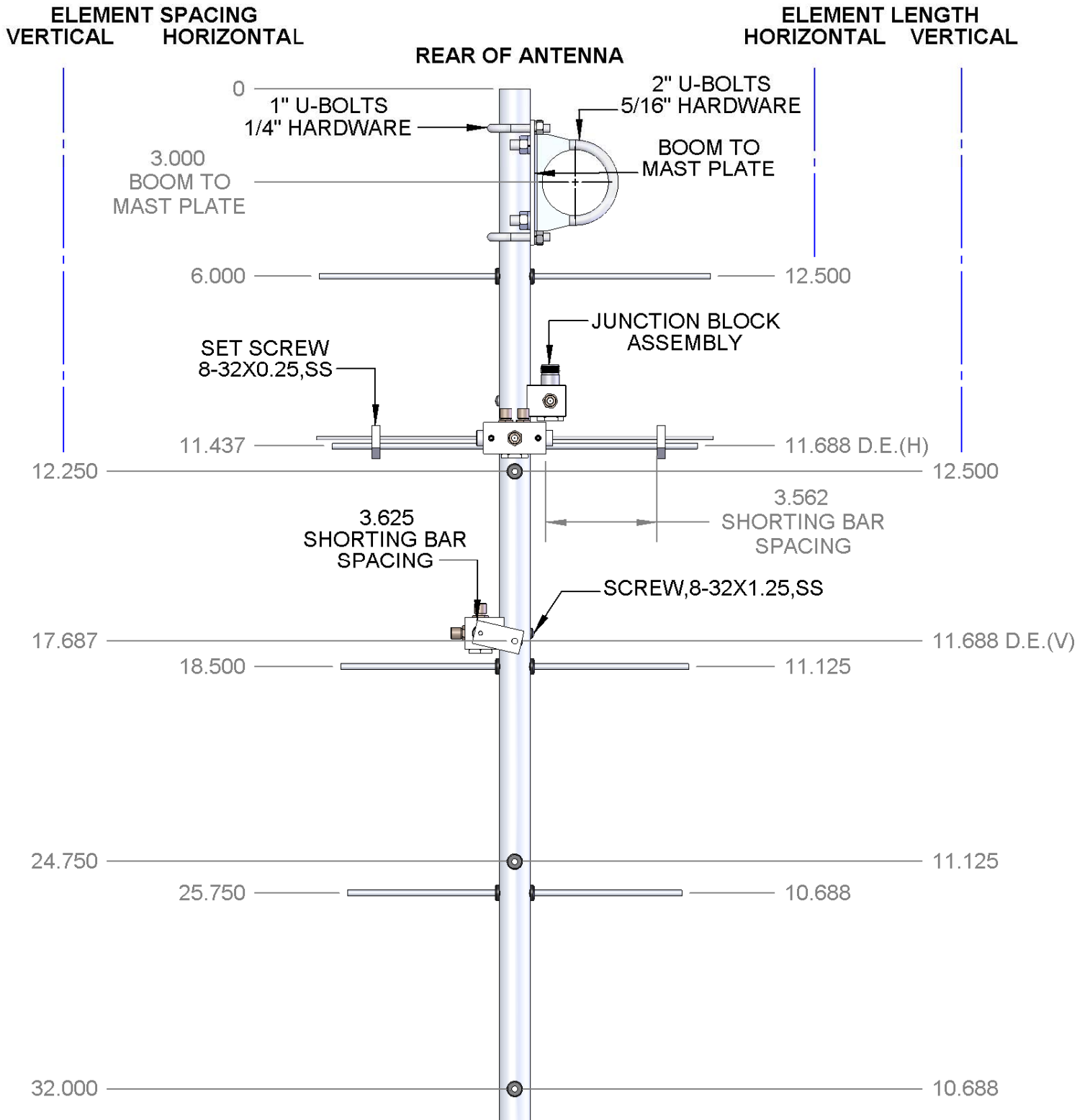

NOTE: DRIVEN ELEMENT BLOCKS SHOWN POSITIONED FOR RIGHT HAND CIRCULARITY

466CP8 PARTS & HARDWARE

DESCRIPTION	QTY.
Main Crossboom, 1 x .058 x 33" PLAIN	1
Boom to mast plate, 3 x 4 x .125"	1
Elements, 3/16" alum. rod x (see dims.)	8
(H) D. E. Block Assembly, (Rod Length = 11.250).....	1
(V) D. E. Block Assembly, (Rod Length = 11.000).....	1
"T" Block Assembly.....	1
<i>Balun, RG-6U halfwave length</i>	<i>2</i>
<i>Phasing line, RG6-U quarterwave length</i>	<i>1</i>
<i>Phasing line, RG6-U three quarterwave length</i>	<i>1</i>
U-bolt and cradle, 2"	2
U-bolt and cradle, 1-1/2"	2
U-bolt, 1" no cradle	2
Assembly instructions	1

IN HARDWARE BAG

Shorting bars, .75 x 1.532 x .250" mach. alum.	4
Button insulators, 3/16" black	16
Shaft Retainers, 3/16" ss	16
Nut, 5/16-18 ss	4
Lockwasher, 5/16" ss.....	4
Screw, 8-32 x 1-1/4" panhead	3
Set screw, 8-32 x 1/4" ss	8
Nuts, 1/4-20 ss	4
Lockwasher, 1/4-20 ss	4
Seal nuts, 3/8-32 gold zinc	8
Allen wrench, 5/64"	1
Push tube, 3/8 x 3" (for keeper installation)	1
Cable ties, 8"	6

M² ANTENNA SYSTEMS, INC.

4402 N. SELLAND AVE.

FRESNO, CA 93722

(559) 432-8873 FAX: 432-3059

www.m2inc.com Email: sales@m2inc.com