

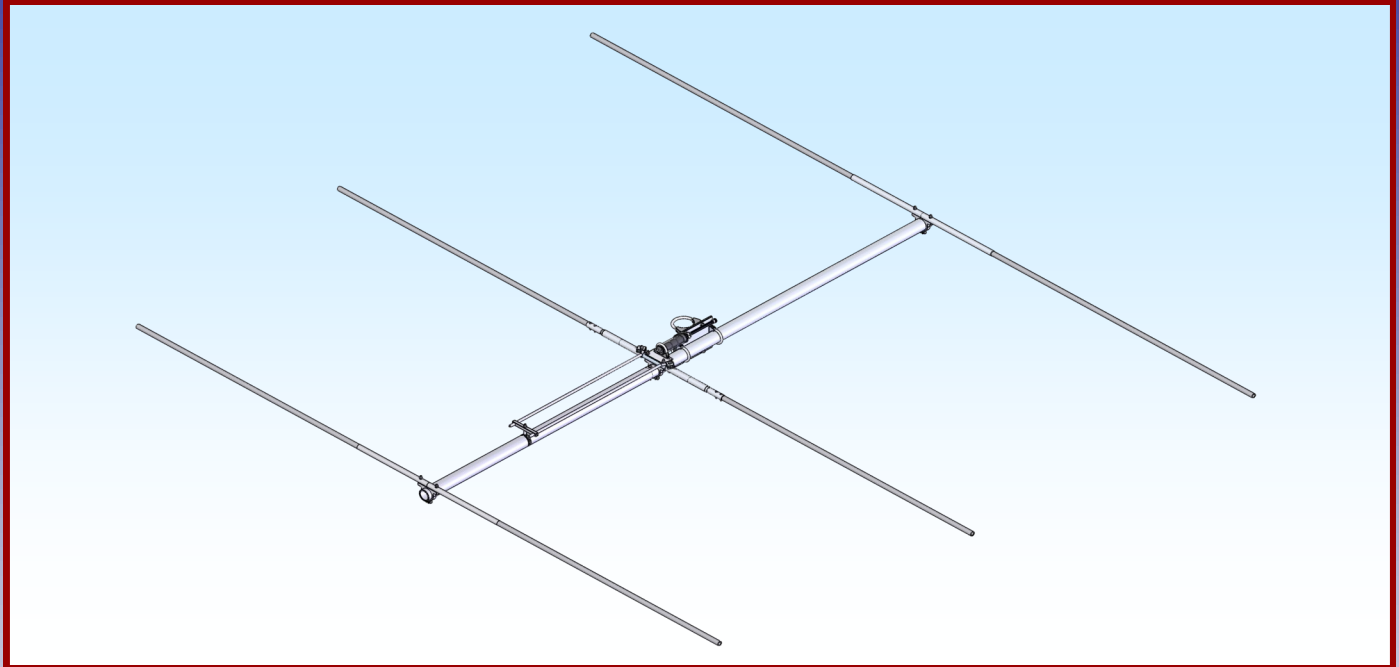

M2 Antenna Systems, Inc. Model No: 41-3BB



SPECIFICATIONS:

| | | | |
|----------------------|--------------------|-----------------------------|-----------------------|
| Model | 41-3BB | Power Handling | 1.5 kW |
| Frequency Range..... | 40.6-41.70 MHz | Boom Length / Dia..... | 107" / 2" |
| *Gain | 7.69 dBi | Maximum Element Length..... | 172" |
| Front to back | 19 dB Typical | Turning Radius: | 101" |
| Beamwidth | E=60° | Stacking Distance..... | N/A |
| Feed type | Hair Pin Match | Mast Size | 2" Nom. |
| Feed Impedance. | 50 Ohms Unbalanced | Wind area / Survival | 1.5 Sq. Ft. / 100 MPH |
| Maximum VSWR..... | 1.5:1 | Weight / Ship Wt..... | 35 Lbs. / 40 Lbs. |
| Input Connector..... | "N" Female | | |

***Subtract 2.14 from dBi for dBd**

FEATURES:

The **41-3BB** has been computer optimized from the ground up for gain and pattern covering 40.6-41.7 MHz. The original design was for the USDA / NCRS Soil Monitoring systems, but the **41-3BB** can also be used for Meteor Scatter applications. The custom 1:1 Fairite balun and low loss hairpin match help maintain high efficiency. Element ring clamps and other important components are CNC machined for maximum strength and electrical integrity. All antenna hardware is stainless steel and the u-bolts for mounting are zinc plated.

M2 Antenna Systems, Inc. has well over 30 designs for Meteor Scatter applications covering from 39 MHz to 50 MHz. If you have a specific requirement, please contact us for more details.

41-3BB DIMENSION SHEET

TOOLS REQUIRED: Screwdriver, 11/32 wrench, socket or spintite, a 7/16" and 1/2" wrench or socket, tape measure.

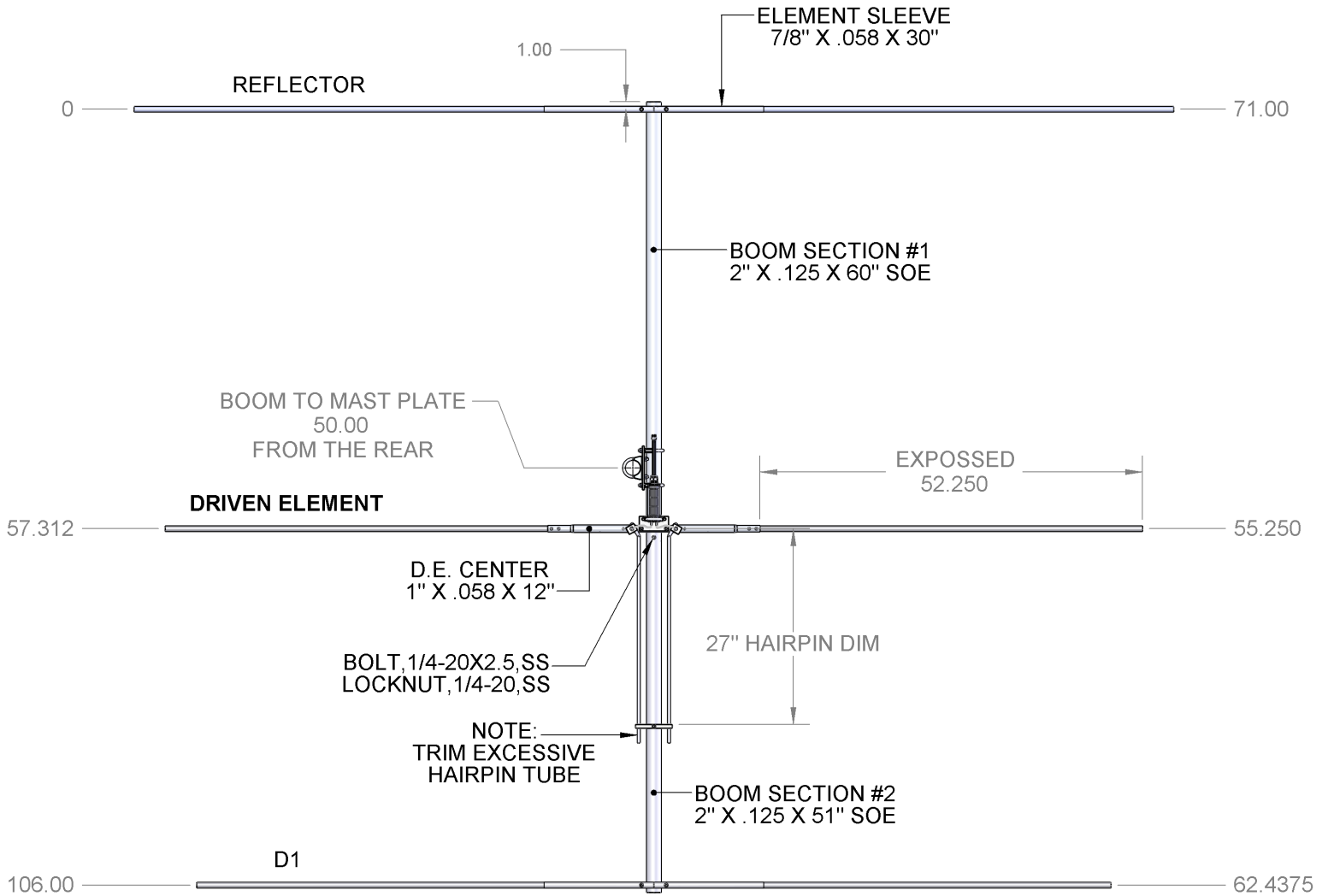

41-3BB ASSEMBLY DETAIL

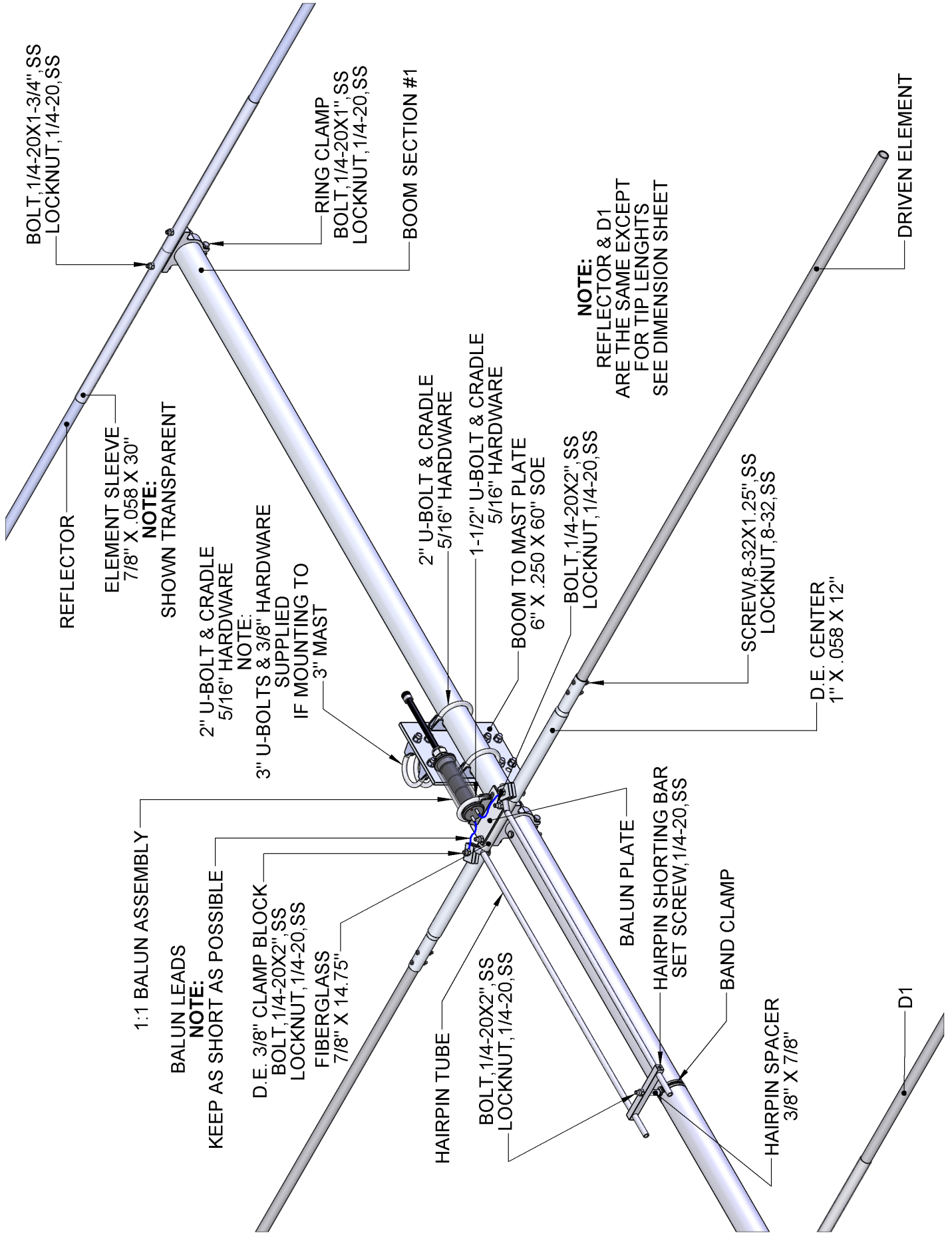

41-3BB PARTS & HARDWARE

| DESCRIPTION..... | QTY |
|--|-----|
| BOOM SECTION #1: 2" X .125 X 60" SOE..... | 1 |
| BOOM SECTION #2: 2" X .125 X 51"..... | 1 |
| DE ELEMENT CENTER, 1.0" X .058 X 12 SOE"..... | 2 |
| ELEMENT TIPS, 3/4" X .049 X SEE SHEET..... | 6 |
| FIBERGLASS DE CENTER, 7/8" X 14.75" (M2AFG0048)..... | 1 |
| ELEMENT SLEEVE, 7/8" X .058 X 30.00"..... | 2 |
| RING CLAMP 2"..... | 3 |
| HAIRPIN SHORT BAR..... | 1 |
| HAIRPIN SHORT BAR SPACER, 3/8" X 7/8"..... | 1 |
| HAIRPIN TUBE 3/8" X 30.25"..... | 2 |
| DE 3/8" CLAMP BLOCK, 1" X .250 X 1.250" (M2AMC0261)..... | 4 |
| BALUN PLATE, 1/8" X 2.0 X 4.0"..... | 1 |
| BOOM TO MAST PLATE, 6" X .250 X 8"..... | 1 |
| (3) FAIRITE 1:1 VHF BALUN ASSEMBLY WITH LEADS..... | 1 |
| BAND CLAMP WITH HOLE, 2 TO 2-1/2"..... | 1 |
| PENETROX / ZINC PASTE CUP..... | 1 |
| ASSEMBLY MANUAL..... | 1 |

HARDWARE:

| | |
|---------------------------------|----|
| U-BOLT AND CRADLE, 3"..... | 2 |
| U-BOLT AND CRADLE, 2"..... | 6 |
| U-BOLT AND CRADLE, 1-1/2"..... | 1 |
| LOCKWASHER,3/8,SS..... | 4 |
| NUT,3/8-16,SS..... | 4 |
| LOCKWASHER,5/16,SS..... | 14 |
| NUT,5/16-18,SS..... | 14 |
| BOLT,1/4-20X2.5,HEX HD,SS..... | 2 |
| BOLT,1/4-20X2.0,HEX HD,SS..... | 5 |
| BOLT,1/4-20X1.75,HEX HD,SS..... | 4 |
| BOLT,1/4-20X1.0,HEX HD,SS..... | 3 |
| SET SCREW,1/4-20X.250,SS..... | 2 |
| LOCKNUT,1/4-20,SS..... | 14 |
| SCREW,8-32X1.25, PH PHL,SS..... | 4 |
| LOCKNUT,8-32,SS..... | 4 |
| ALLEN KEY, 1/8"..... | 1 |

M² ANTENNA SYSTEMS, INC.

4402 N. SELLAND AVE.

FRESNO, CA 93722

(559) 432-8873 FAX: 432-3059

www.m2inc.com Email: sales@m2inc.com