

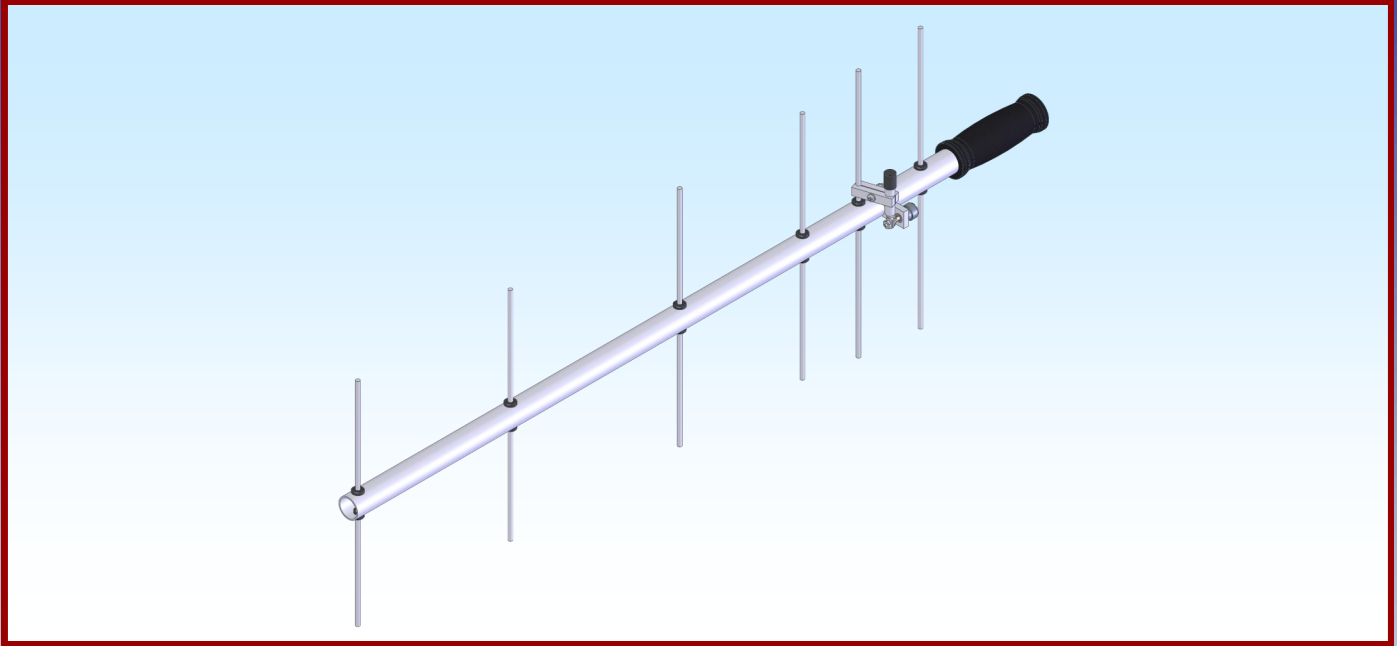

M2 Antenna Systems, Inc. Model No: 440-6SX



SPECIFICATIONS:

Model	440-6SX	Power Handling	500 Watts
Frequency Range	420 To 450 MHz	Boom Length / Dia	36' / 1"
*Gain	11 dBi	Maximum Element Length	13-5/8"
Front to back	18 dB Typical	Turning Radius:	34-1/8"
Beamwidth	E=55° H=65°	Stacking Distance	27" High & 30" Wide
Feed type	Gamma Match	Mast Size	1-1/2" to 2" Nom.
Feed Impedance	50 Ohms Unbalanced	Wind area / Survival	0.3 Sq. Ft. / 75 MPH
Maximum VSWR	1.5:1	Weight / Ship Wt.	3 Lbs. / 4 Lbs.
Input Connector	SO-239		

***Subtract 2.14 from dBi for dBd**

FEATURES:

The **440-6SX** a low cost, medium performance antenna and a great choice for a rugged hand held operation without compromising quality. A comfortable rear mount handle and all stainless hardware, give you the confidence of quality construction you have come to expect from **M2**. Built with size and portability in mind, this antenna is great for hand held tracking applications. The antenna breaks down to no more than 36" long, making it a natural for portable operations.

440-6SX ASSEMBLY MANUAL

Tools handy for assembly process: Phillips head screwdriver, 5/16",11/32" spin-tight or socket, 7/16" end wrenches / sockets, measuring tape.

1. This antenna uses a one-piece boom that will be rear mounted.
2. Lay out the elements by length and position as shown on the **DIMENSION** sheet. Start with the reflector (longest) element and push on a black button insulator to about 1/2" from the center of the element. Push the reflector element through the element hole towards the rear of the boom. (Refer to the **DIMENSION** sheet for proper placement) Install the second button insulator on the other side of the element, pushing it up into boom. **DO NOT BOTHER WITH ACCURATELY CENTERING** the element at this time and **DO NOT INSTALL** the stainless steel internal locking keepers yet. This is easier to do after all of the elements are installed in the boom.
3. Install the **DRIVEN ELEMENT** in the same way as you did the reflector element. Then continue with the installation of the **DIRECTOR or DIRECTORS**.
4. Now begin centering the elements. Use a tape measure to **EQUALIZE** the amount of each element sticking out on each side of the boom. Once you have all of the elements centered, sight down the element tips from the rear comparing each side. Look for any obvious discrepancies and correct if found.

5. Install the stainless steel keepers to secure the elements. **NOTE:** For portable or temporary use of the antenna, the keepers may be left off. The button insulators, (normally a tight fit) hold the elements quite securely.

To install, use thumb and forefinger to hold the keeper over the end of the **PUSH TUBE**. Make sure that the internal fingers of the keeper are dished into the push tube. **HOLD THE ELEMENT FIRMLY TO PREVENT IT FROM SLIDING OFF CENTER** and press the keeper onto the element end and continue until the keeper is snug on the insulator button.

Locking pliers, *lightly* clamped up against the opposite button insulator, will help maintain center reference. If you push the first keeper too far, remove the element from the boom, push the keeper completely off the element, and start over. Install another keeper to the opposite side of the element. Continue installing keepers until all elements are locked in place.



6. Next, assemble the Gamma Match assembly. Start by sliding a #6 flat washer over the end of the Gamma Feed block stud.

7. Slide the Gamma Insulator over the Gamma Rod, leaving 1/8" of the insulator exposed beyond the end of the Gamma Rod. Slide this Gamma Rod and Insulator over the end of the Gamma Feed block stud.

8. Now, slide a #6 lock washer over the Gamma Feed block stud and finish the assembly with a 6-32 nut. ***Note*** The connector stud can spin freely. Use a pair of needle nose pliers or a small wrench to hold the flat surface when tightening.

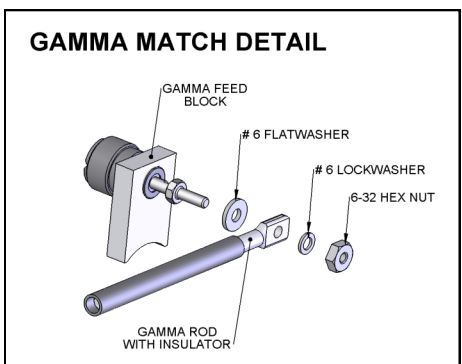

9. Next, attached the Gamma Match assembly to the boom, using a single 8-32 x 1 1/4" screw. Make sure to orient the Feed connector towards the rear of the antenna.

10. Now slide the Gamma Tube over the Gamma Insulator and refer to the **DIMENSION** sheet for proper placement.

440-6SX ASSEMBLY MANUAL

11. Install the two halves of the Shorting Bar onto the Gamma Tube and the driven element below. Refer to the **DIMENSION** sheet for proper location of the shorting bar. Tighten the shorting bar in place using a single 8-32 x 7/8" screw and lock nut.
12. Now Slide the 3/8" x 3/8" Vinyl cap over the Gamma Tube until it is flush with the end of the Gamma Tube.
13. Slide the foam padded rear mount handle into place.
14. **For hand held operation**
Route the feed line coax towards the rear of the antenna past the reflector element. Use the supplied adapter for quick disconnect using a BNC connector. Secure the feed line coax to the antenna boom with the supplied nylon ties. **For the best performance try to match the polarity of the source and tracking antennas. When fixed mounting is required with the antenna vertically polarized, make sure to orient the gamma tube with the vinyl cap facing up.**

To maintain good VSWR and antenna pattern: Keep metallic masts, cross booms and the feed line coax out of the element plane.

Stacking or Phasing ? Call us and let us help you DO IT RIGHT.

THIS COMPLETES THE ANTENNA ASSEMBLY.

Carefully manufactured by:

M² ANTENNA SYSTEMS, INC.

4402 N. Selland Ave.

Fresno, CA 93722

(559) 432-8873 Fax: 432-3059

www.m2inc.com Email: sales@m2inc.com

GENERIC GAMA MATCH ASSEMBLY DETAIL

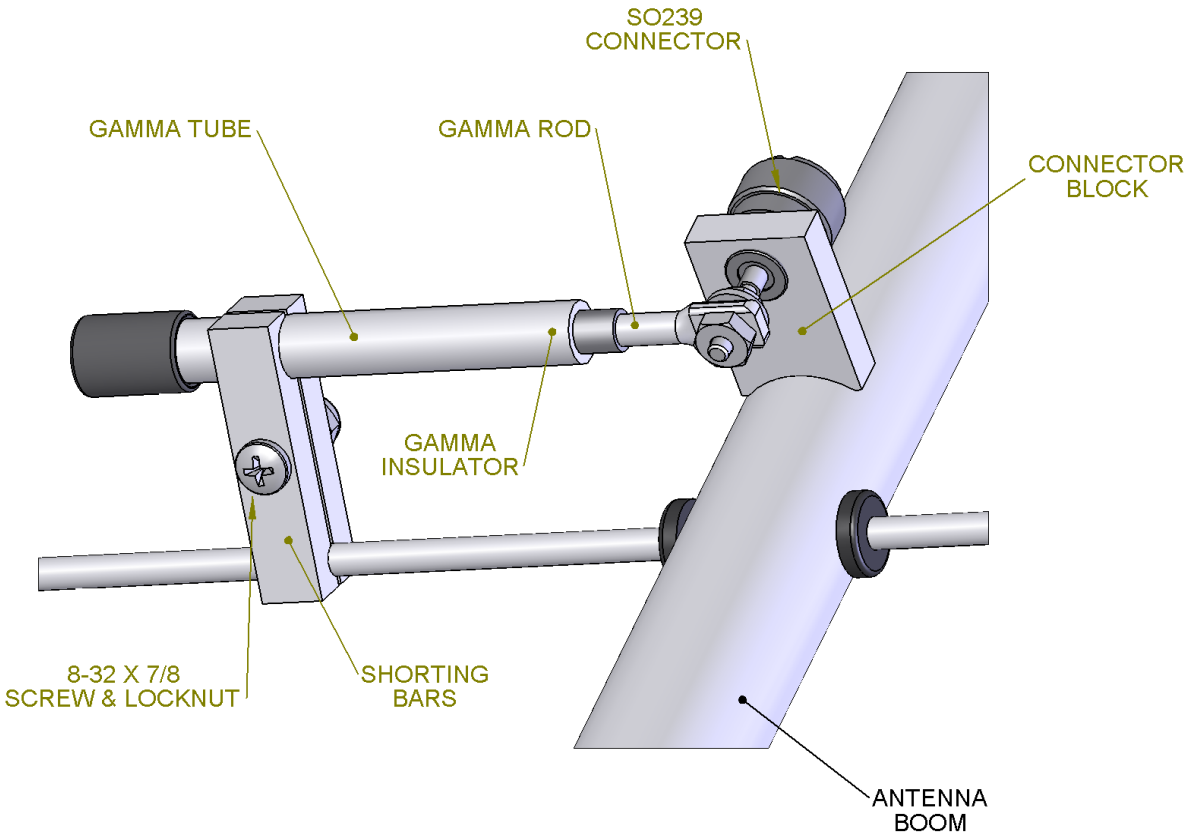

440-6SX DIMENSION SHEET

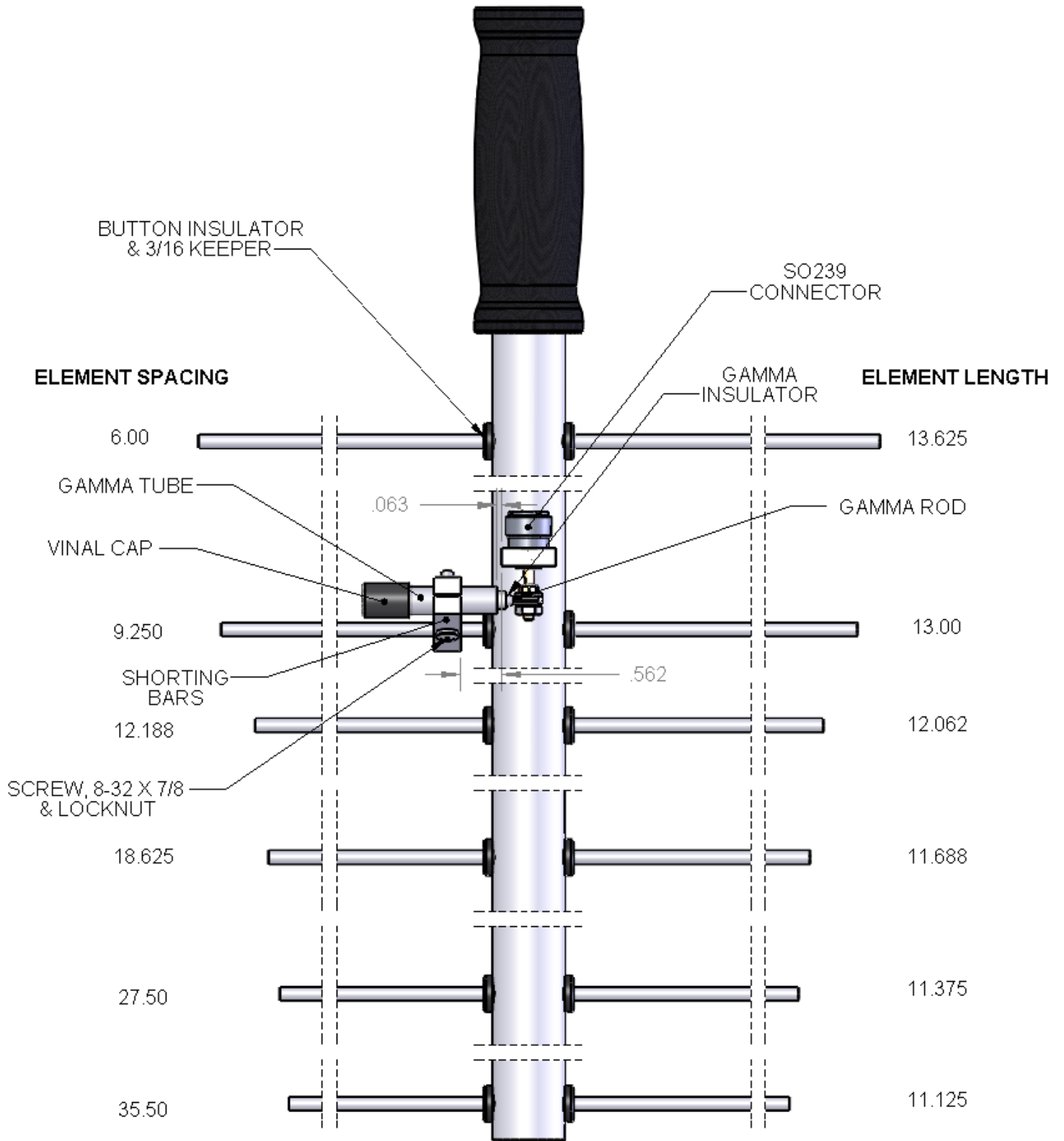

440-6SX PARTS & HARDWARE

DESCRIPTION.....	QTY
BOOM SECTION, 1 X .058 X 36"	1
ELEMENTS, 3/16 ROD X SEE DIM SHEET	6
GAMMA CONNECTOR BLOCK ASSEMBLY	1
GAMMA ROD, 3/16 X 2.0 ALUM ROD	1
GAMMA TUBE, 3/8 X .058 X 1.750 ALUM TUBE	1
GAMMA INSULATOR, .1/4 X .031 X 1.625 TEFLON TUBE... 1	
VINYL CAP, 3/8 X 3/8	1
FOAM HANDLE	1
ASSEMBLY MANUAL.....	1

HARDWARE BAG:

SHORTING BAR, 1/4 X 3/8 X 1.688	2
BUTTON INSULATORS, 3/16	12
KEEPERS, 3/16 SS	12
SCREW, 8-32 X 1.25 SS	1
SCREW, 8-32 X .875 SS	1
LOCKNUT, 8-32 SS	1
FLATWASHER, #6 SS.....	1
LOCKWASHER, #6 SS.....	1
NUT, 6-32 SS.....	1
NYLON TIE, 7 3/4	3
PUSH TUBE, 3/8 X 3"	1

Carefully manufactured by:

M² ANTENNA SYSTEMS, INC.

4402 N. Selland Ave.

Fresno, CA 93722

(559) 432-8873 Fax: 432-3059

www.m2inc.com Email: sales@m2inc.com