

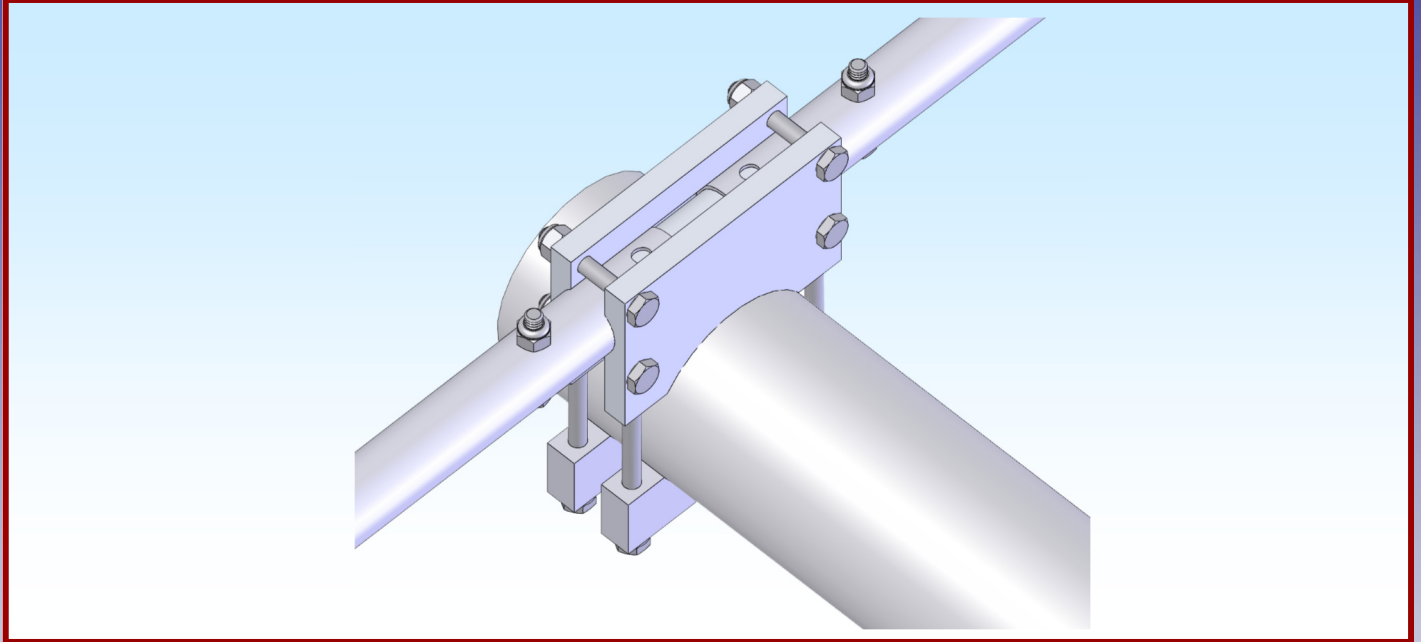

# M2 Antenna Systems, Inc.

## Model No: FGKLMUP13



### SPECIFICATIONS:

Model .....	FGKLMUP13
Element Size.....	1" X 0.058
Boom Dia .....	3.0"
Weight.....	4 Lbs.

### FEATURES:

Machined from solid aluminum, the FGKLMUP13 replaces the older plastic KLM element clamps used in KLM's original KT-34 design. Using ultra-precise computer numerically controlled (CNC) manufacturing techniques, these clamps provide a secure grip under even the worst conditions. All-aluminum clamp construction eliminates susceptibility to ultra-violet radiation, wind and cold.

Direct replacement for the reflector and director elements on the KLM KT-34 series, these require very little additional work to replace weakened plastic pieces. They clamp easily to the boom and eliminate stresses resulting from the split-element concept by joining each half with a 7/8" diameter aluminum reinforcing tube for a single super-strong, ultra-resilient element.

Other antennas can also benefit from this upgrade. Many popular HF antennas, made by KLM and other manufacturers use 1" diameter tubing with .058" wall thickness for elements. On a 3" boom, this element clamp is ideal.

Do you have an HF antenna design that you would like to try? These clamps are perfect for home brew projects. Use them with 1" x .058" tubing to create reflectors and directors for your own Yagi or log periodic design.

# KLM TO M2 (KT34 & KT34XA) CONVERSION KIT

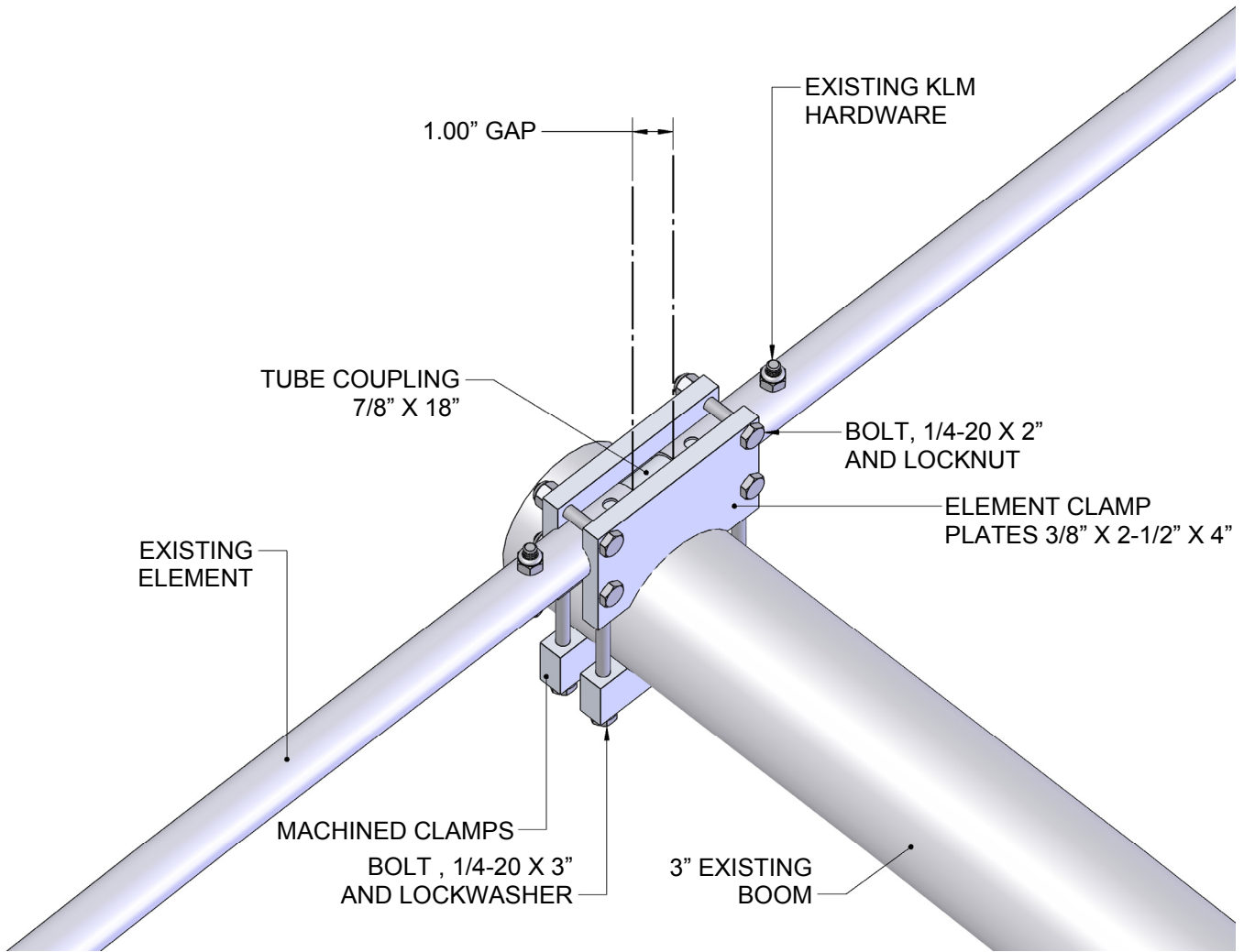

1. Assemble the HF Element Clamp Plates and install the 7/8" X 18" aluminum tubing as shown.

2. Mark Location of Drill Hole, use a #9 (0.281) drill bit and drill thru coupling tube. Repeat for other side.

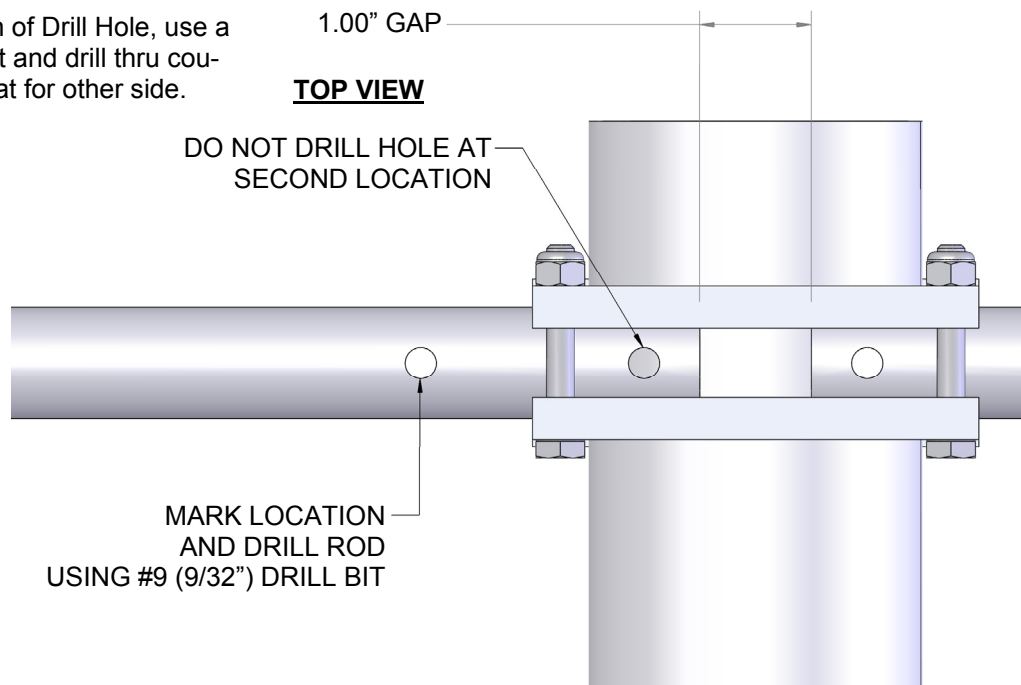

# (FGKLMUP13) PARTS & HARDWARE

<u>DESCRIPTION</u>	<u>QTY</u>
TUBE COUPLING 7/8" X 18" .....	1
HF ELEMENT CLAMP, 3/8" X 2-1/2" X 4" (M2AEC0038).....	2
MACHINED CRADLE, 3" (M2AMC0136) .....	2
 <b>HARDWARE</b>	
BOLT, 1/4-20 X 3" SS.....	4
BOLT, 1/4-20 X 2" SS.....	4
LOCKWASER, 1/4" SS.....	4
LOCKNUT, 1/4-20, SS .....	4

## **M<sup>2</sup> ANTENNA SYSTEMS, INC.**

4402 N. Selland Ave.

Fresno, CA 93722

(559) 432-8873 Fax: 432-3059

[www.m2inc.com](http://www.m2inc.com) Email: [sales@m2inc.com](mailto:sales@m2inc.com)