

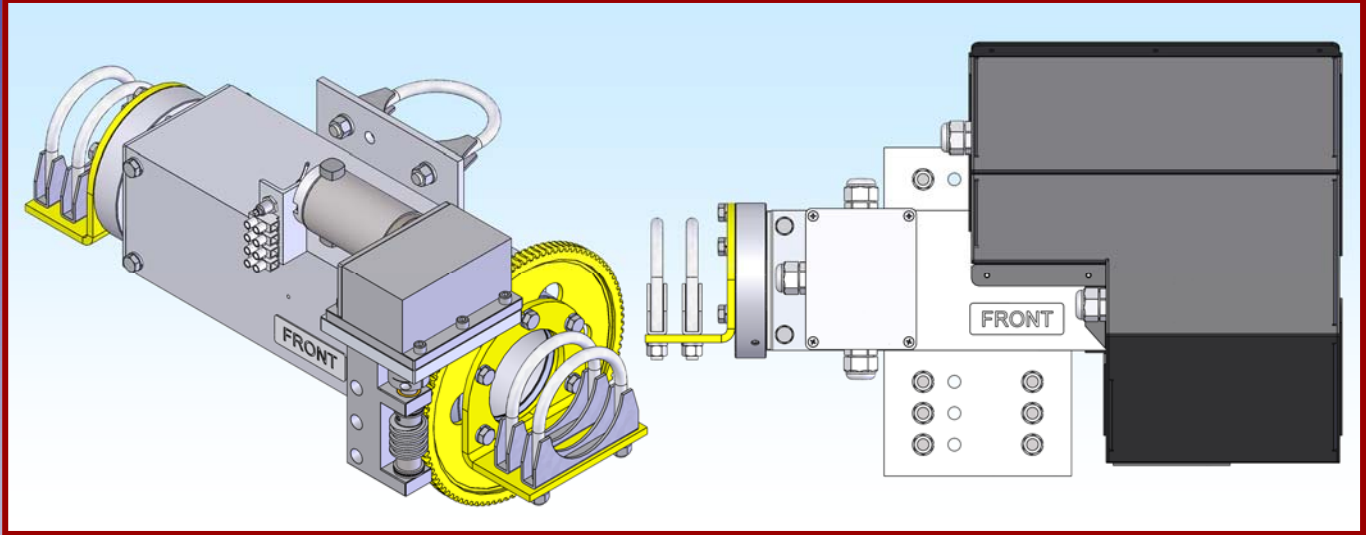

# M2 Antenna Systems, Inc.

## Model No: MT-1000AEL



### SPECIFICATIONS:

Model Number.....	MT-1000AEL positioner and RC2800P controller
Rotational Torque.....	2400 in. lb. minimum at lowest speed
Gear Ratio.....	6600:1
Rotation Time.....	0-90 deg.15 seconds maximum down to 150 seconds minimum.
Construction.....	Aluminum and Steel, welded and gold-zinc plated.
Mast Size.....	accommodates 2 and 3 inch dia.
Crossboom Size.....	1-1/2 to 3 inch dia.
Weight.....	24 lb. / Positioner and 13 lb. / Control Unit
Shipping Weight.....	40 lb. by UPS

### FEATURES:

The MT-1000AEL is a rugged, mid-size elevation mechanism designed to handle the most common EME and satellite antenna systems. It has been designed with a powerful, low backlash, double worm gear reduction and a full circumference ball bearing main boom rotation system. A full 360 degree rotation of the main crossboom makes array assembly and maintenance a breeze. The 3 inch main bearings handle up to a 3 inch diameter crossboom which rotates on axis with the weight centered over the top of a supporting tower. A powerful new permanent magnet dc servo motor produces 2 pulses per each rotation, resulting in a .1 degree pointing accuracy and repeatability. Speed range is spectacular going from 0 to 90 to 180 degrees in 30 seconds at top speed #9, down to 5 minutes low speed #1! Full output torque is produced at even the slowest speed.

The M<sup>2</sup> RC2800PXEL controller with RS232 interface is compatible with Nova and Sky moon tracking programs, or manual and straight terminal keyboard entry. The controller features speed control, travel limits and 10 preset headings.

The MT-1000AEL is designed to handle up to eight 36 foot Yagi's. It is perfect for large satellite arrays/EME com bos, or just for modest antenna systems where the weather may be too much for smaller mechanisms.

Even with all its power and ruggedness, the MT-1000AEL is light weight (24 lb.). Fabricated from aluminum with judicious use of steel where needed, M<sup>2</sup> has succeeded in filling the gap between the light duty Yaesu 500 and the heavy duty M<sup>2</sup> MT-3000AEL. An attractive unit with its silver aluminum and gold zinc steel worm drive ring, these units impress even the most sophisticated user. The M<sup>2</sup> OR2800P azimuth rotator is a perfect mate for the MT-1000AEL and, of course, we have an optional dual rackmount AZ-EL controller (RC2800PRK) with the same features for both units.

# MT-1000EL MOUNTING OPTIONS

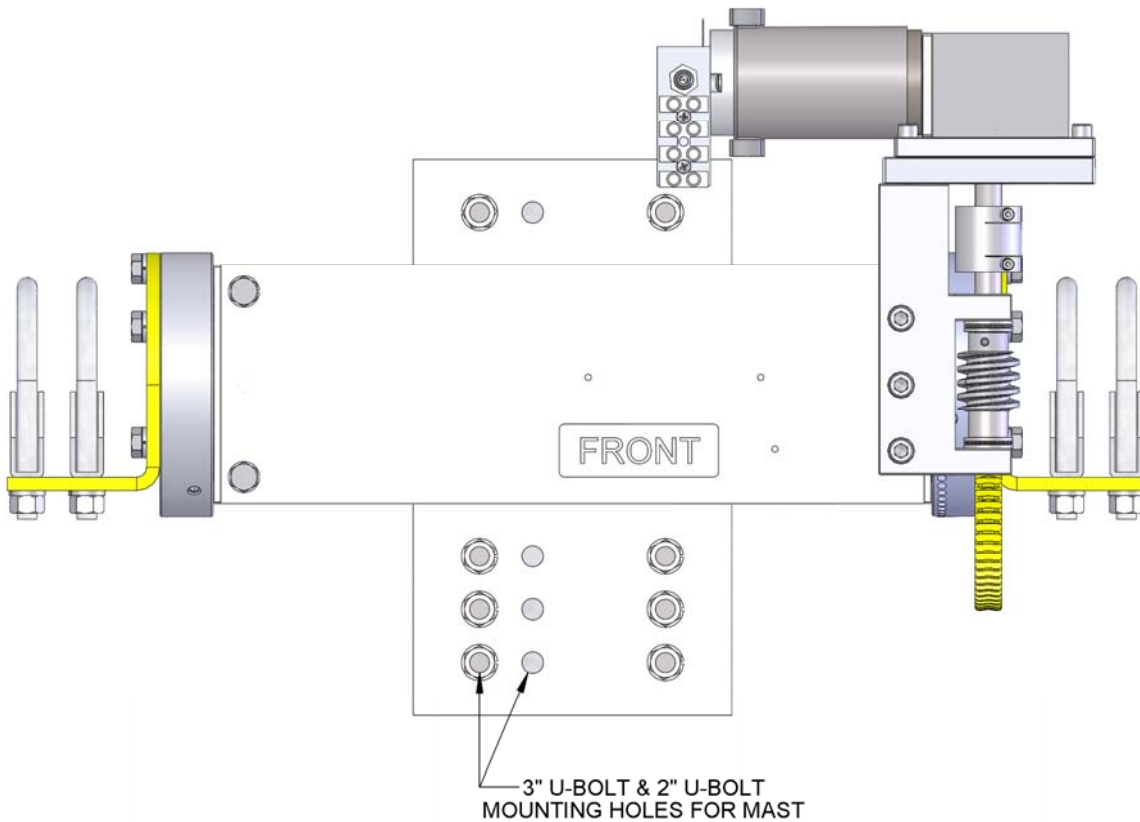
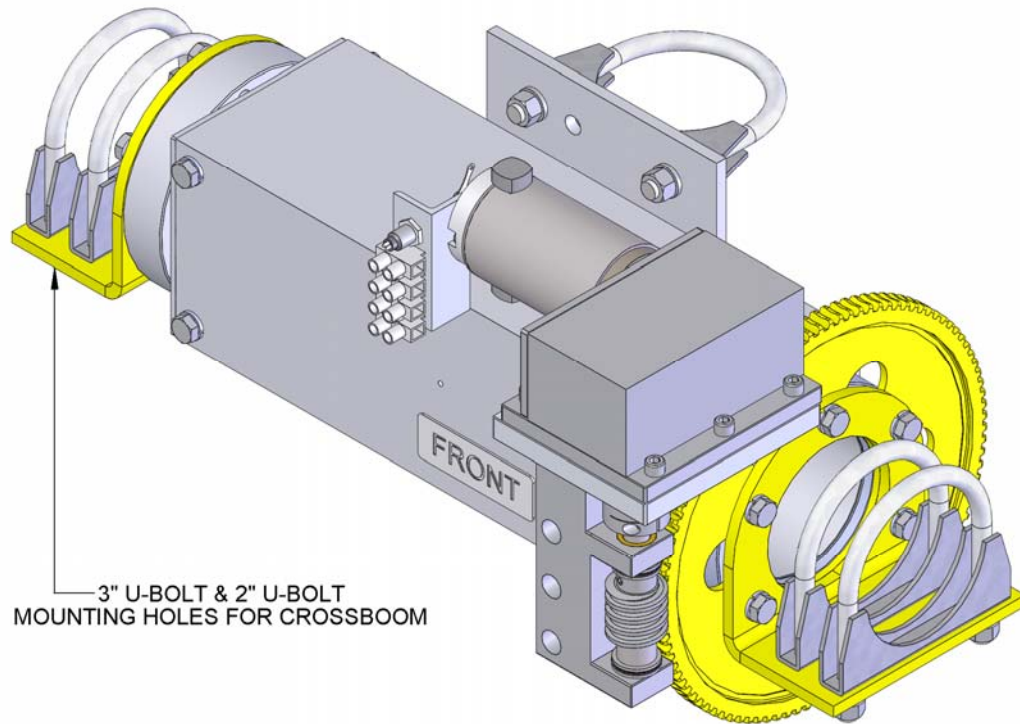

# MT-1000 OPTIONAL COVER

Position cover as shown. Mark holes on cover that inter face with MT-1000 body (3 Sides). Remove cover and use #32 (0.116) drill bit to drill marked holes. Install cover with supplied Self tapping 6-32 screws. M2 has supplied 6-32 x 1/2 ss screws and lock nuts for the covers flange edges. Removing just 1 half of the cover is recommended for inspection.

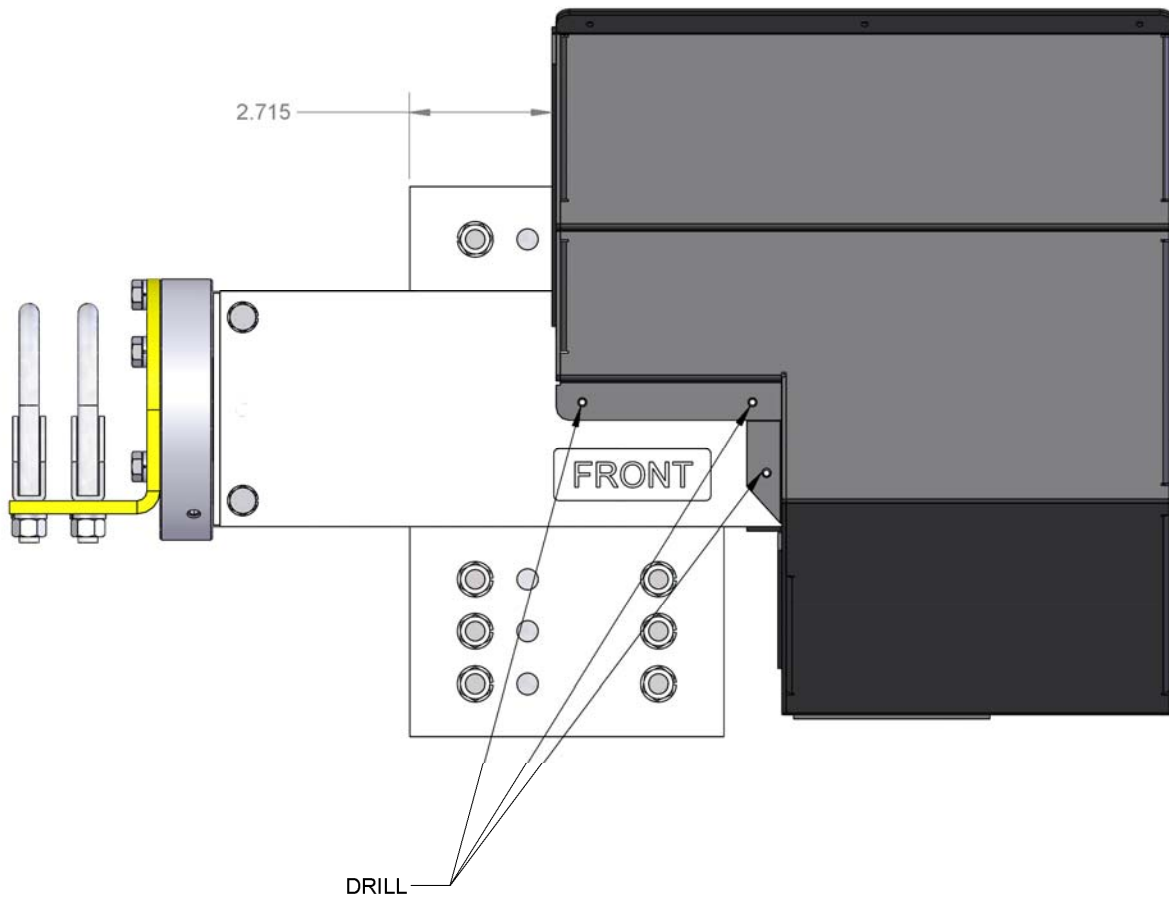

# MT-1000EL LIMIT SWITCH KIT OPTION

**Note:** The optional Limit switches kit and cover are factory installed.

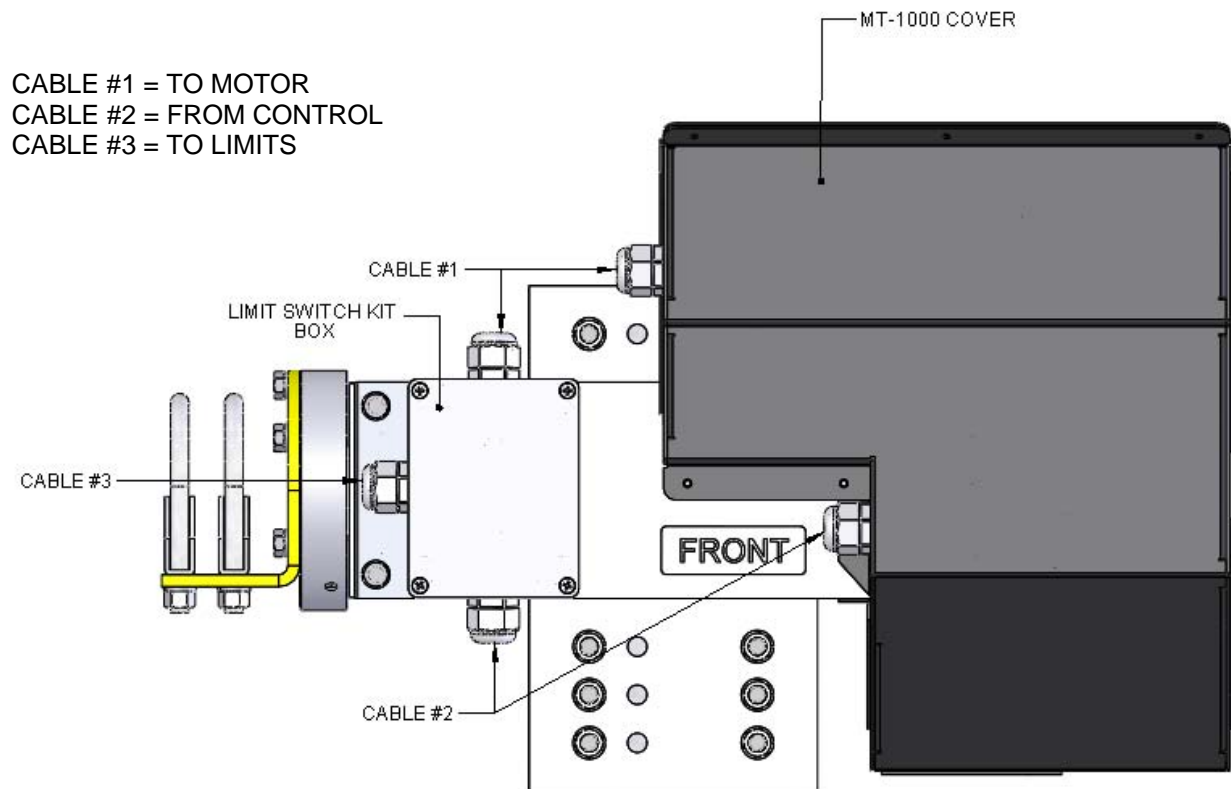

**Note:**

The cover not show for clarity.

For more information on how to set up the Limit Stop set screws.

Refer to Limit Switch Kit test page.

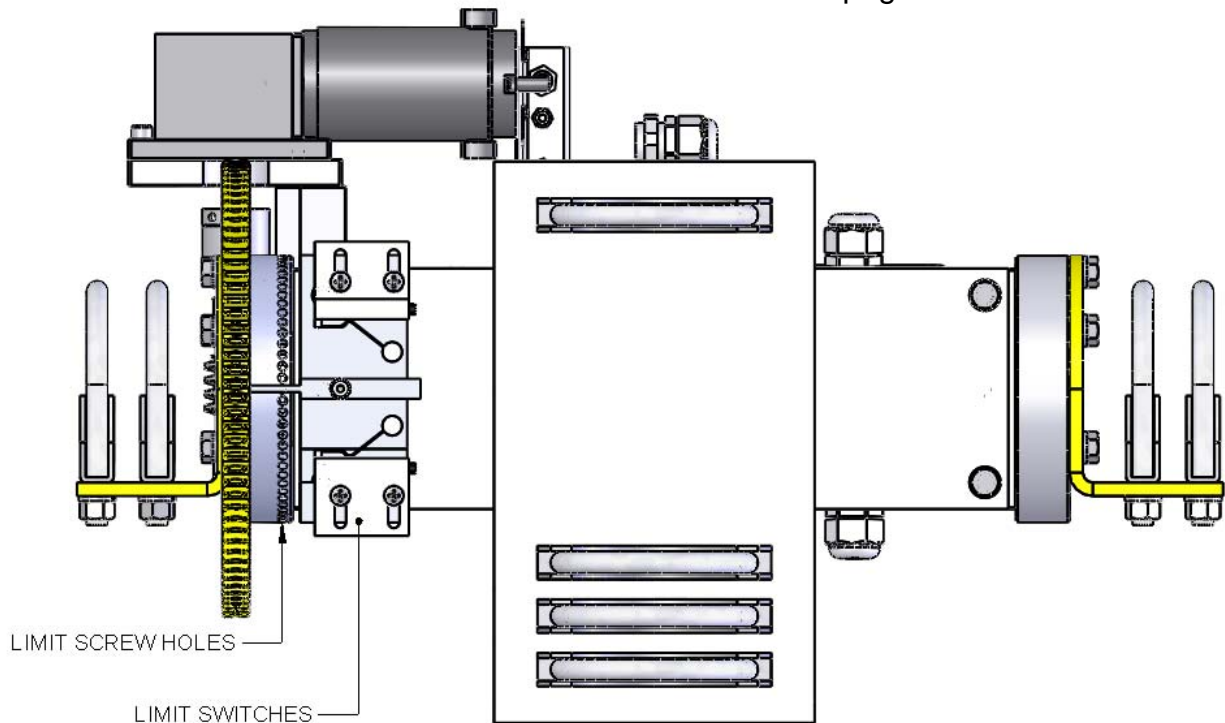

# MT-1000AEL BENCH TEST WITH OUT LIMIT SWITCHES

1. To become familiar with the operation of the MT-1000EL its operation and also to set up the programmable features of the **RC2800PXEL** control unit, the MT-1000AEL can be clamped in a vice or "C" clamped to a bench. The large ring gear and large exposed worm need to be lubricated to prevent wear in these areas. Lubrication for light bench testing is not necessary. When the unit is up and you are through handling and installing it, then lubricate the ring gear over the part of the diameter you expect to be using on a regular basis. In most cases you will set up the limits in the RC2800PXEL control box to 0 degrees and 90 degrees. If this is your choice, then lubricate AT LEAST that section of the ring gear. Only a light coat of white grease is required. It can be put on with an acid brush or small paint brush. The grease only needs to be on the worm and in the teeth of the ring. Wipe off excess if desired.
2. For Bench testing almost any wire size can be used. Attach the control cable (2 wires for the DC motor and two wires for the pulse system). The terminal strip is located on the rear of the DC motor. PLEASE note the two white wires entering the terminal strip are the pulse wires. DO NOT CONNECT THE MOTOR WIRES HERE OR SEVERE DAMAGE WILL OCCUR TO THE REED SWITCH. Follow the wiring instructions in the RC2800PXEL manual. This manual will also provide proper wire sizes for variable run lengths. The control unit puts out approximately 38 DC volts when it is unloaded. This extra voltage compensates for resistive losses over long cable runs. When bench testing with short leads, the motor may run at slightly higher speed than in its final location on you tower.
3. When the MT-1000AEL is shipped from the factory without a limit switch kit the MT-1000 is complete flexible in direction of rotation and which direction you point your antenna array. During your bench testing, pick a basic direction you plan to point (toward or away from the motor). If you push the UP button on the RC2800PXEL controller, and the MT-1000AEL rotates DOWN, then reverse the wires to the motor at the terminal strip at the motor or on the rear of the control box.
4. When the MT-1000AEL is shipped is with the limit switch kit installed at the factory, the front of the MT-1000 will be labeled. See the RC2800PXEL controller manual for calibration procedures for with and without limit switch kit.
5. Once you have established pointing and rotation direction, then program the Controller **MODE #4** to 13200 (6600:1 gear ratio X 2 (two magnets create 2 pulses per rotation). Save this and then go back into Mode #1 and set it to '0.00 which is now your lower rotation limit. If you set this Mode #1 number to 5 and save it, you will be able to go below 0 to -5 degrees (L355.0 in the readout). If you system requires that you limit ABOVE 0, you will have to get the **OPTIONAL LIMIT SWITCH KIT**.

# MT-1000AEL BENCH TEST WITH OUT LIMIT SWITCHES

6. Once you have established your lower limit using MODE #1, Go back into program mode #2 and set your upper limit. If you will need to invert the array during assembly, then set the limit to 180. If this is not required, then set the UPPER limit to what ever you feel is the adequate travel. BEAR IN MIND, YOU CAN CHANGE ANY PROGRAMMED NUMBER AT ANY TIME. The only two program settings that effect all other settings are Mode #1 and Mode #2. That is why we suggest you do those settings first.

7. If you are ready to CALIBRATE the MT-1000AEL to an exact heading, then go into MODE #6 and set it to the desired heading. This setting can be changed at any time with no effect on any other setting.

8. INSTALLING YOUR ARRAY: Consider what it will take to keep your array well balanced. Sometimes the side you mount the vertical risers on the main crossboom will help or hurt the basic balance of the array. The MT-1000AEL is quite powerful but of course has some limit to its rotational capability. Avoid adding weight to the front or rear of the array to achieve balance whenever possible.



# MT-1000AEL BENCH TEST WITH LIMIT SWITCHES

## LSK-1000 OVERVIEW:

The **LSK-1000** limit switch kit is a physical hard backup limit. The standard control unit supplied with our AZ or EL has “**Electronic Limits**”, but the **LSK-1000** limit switch kit, has been designed as a physical backup system in the event of a control unit failure. The factory has pre-installed the **LSK-1000** limit switch kit into the AZ and EL units for you. Typically the **LSK-1000** limit switches only need to be setup once, but can be adjusted when necessary.

## LSK-1000 MANUAL LIMIT SWITCH PRE-TEST:

Remove one half of the black enclosure from the positioner unit that **DOES NOT** have cord grips or wires running into it. You will see the limit switches (**A,B**) the limit arm (**C**), and limit screw (**D**) as pictured to the right. **We have installed the lower limit screw and have established -5.0 DEG. and the front of the MT-1000.** Move the supplied **RC2800** control unit near the positioner for proper limit switch testing. With the positioner wired to the control unit, turn the control unit on. Be sure to test the proper direction of the positioner before moving forward. Once you have determined the correct direction of rotation from the control units’ “Control Buttons,” determine which limit switch will be activated by the rotation of the main gear and limit screw. Press a known direction using the “Control Buttons,” and manually activate the limit switch. At this point the positioner should stop it’s travel. Continue holding the limit switch and reverse the direction using the “Control Buttons.” The motor should move away from the engaged limit switch. This confirms proper wiring and operation of the limit switch. Repeat this procedure for the other direction and limit switch.

## FINAL LIMIT SWITCH SET UP:

Adjustment of the lower limit should not be necessary, if you feel adjustment is required, we have provided holes for 5 deg adjustments. The upper limit only needs to be set outside of the upper limit. Drive your positioner to the upper electrical limit and install limit set screw outside the limit arm. Setting the upper limit is not needed until after final system assembly.

## AZ/ EL-1000 LIMIT SWITCH ARRANGEMENT

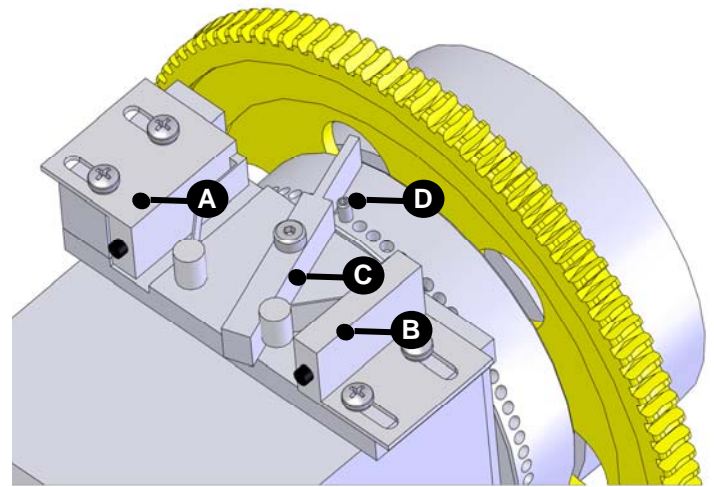

# MT-1000AEL PARTS & HARDWARE

DESCRIPTION	QTY
MT-1000AEL Assembly .....	1
<b>HARDWARE BAG #1:</b>	
U-Bolt, & Cradle 3" .....	4
U-Bolt, & Cradle 2" HD .....	4
Nut, 3/8-16 SS .....	8
Lock Washer, 3/8-16 SS .....	8
<b>HARDWARE BAG #2:</b>	
U-Bolt & Cradle, 3" .....	4
U-Bolt & Cradle, 2" .....	4
Lock Washer, 3/8 SS .....	16
Nut, 3/8-16 SS .....	16
Lock Washer, 5/16-18 SS .....	8
Nut, 5/16-18 SS .....	8
<b>OPTIONAL MT-1000 COVER</b>	
MT-1000 Cover Assembly + Window Cover .....	1
Screw, 6-32 x 1/2", Pan Head, ss .....	12
Lock Nut, 6-32, ss .....	12
<b>OPTIONAL LIMIT SWITCH KIT (LSK-1000)</b>	
<b>FACTORY INSTALLED ONLY</b>	
Limit Screw, 8-32 x 1/2", Set, ss .....	2

## M<sup>2</sup> ANTENNA SYSTEMS, INC.

4402 N. Selland Ave.

Fresno, CA 93722

(559) 432-8873 Fax: 432-3059

[www.m2inc.com](http://www.m2inc.com) Email: [sales@m2inc.com](mailto:sales@m2inc.com)



**NEW PRODUCT UPDATE !**

**New!**

# **Product Update!**

## **“Backlash Adjustment”**

*See next page for more information!*

# WORM & WORMGEAR ADJUSTMENT

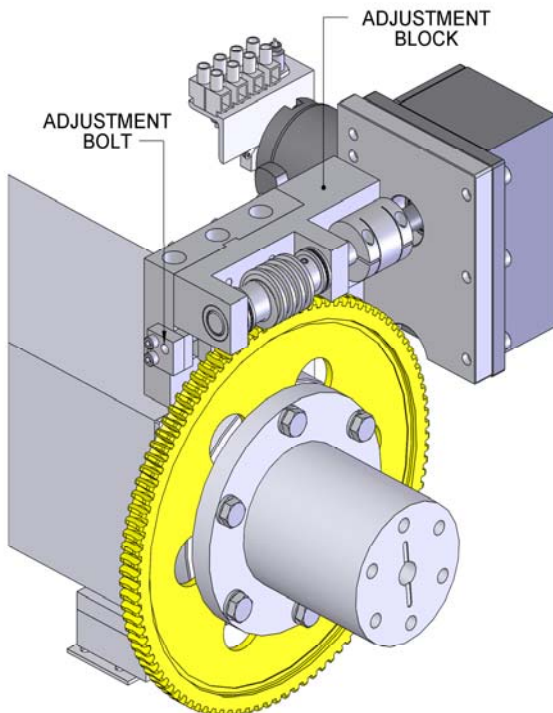
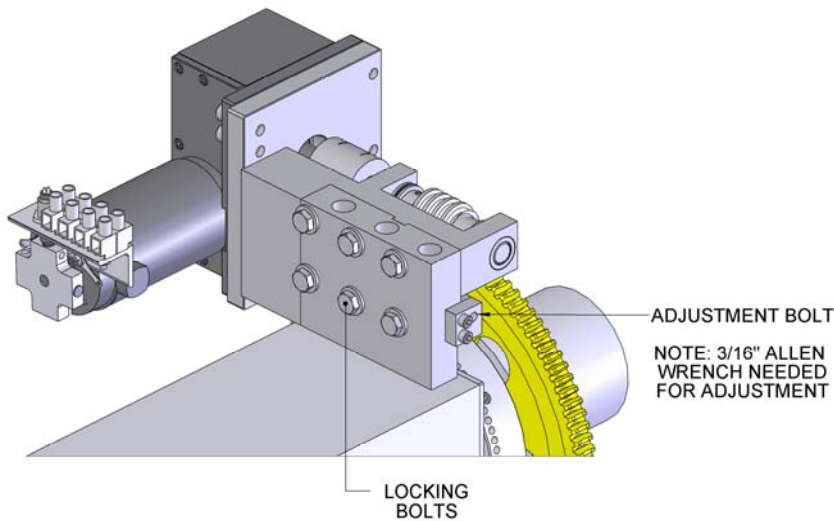

NOTE:  
SOME PARTS ARE NOT SHOWN FOR CLARITY

Excessive backlash may develop after using system for some time. We have incorporated a built in backlash adjustment block to keep backlash at a minimum.

Please review drawings shown for more detailed information.

To adjust system:

1. Slightly loosen locking bolts to hand tight.
2. Use a 3/16" Allen wrench to turn adjustment bolt.
3. One full turn of the adjustment bolt will move adjustment block 0.010 of an inch.
4. Clockwise rotation of the adjustment bolt will move the adjustment block down, moving the worm closer to the worm gear and removing backlash.
5. Counter clockwise rotation of the adjustment bolt will move the adjustment block up, moving the worm away from the worm gear and creating more backlash.
6. Adjustments should be made with the motor running. Use the motor drive sound as gauge for friction between worm and worm gear.

**Note:** Too much friction may cause gear binding in rarely used sections of the worm gear. Some finesse may be required.

7. Tighten locking bolts and test system. Listen for motor running sound for smooth system operation and minimal

# 12 MONTH LIMITED WARRANTY

## **MT-1000AEL / MT3000AEL & RC2800PX**



This warranty gives you specific legal rights. You may also have other rights which will vary from state to state or province to province.

**M2** warrants the MT-1000AEL / MT-3000AEL with RC2800PXEL Control unit against defects in material and workmanship for a **period of 12 months** from date of purchase. During the warranty period, **M2** will, at its option, either repair or replace products or components which prove to be defective. The warranty shall not apply to defects or damage resulting from:

- Improper or inadequate maintenance by user
- Improperly prepared installation site
- Unauthorized modifications or misuse
- Accident, abuse, or misapplication
- Normal wear

**M2** specifically does not warrant this product for any direct, indirect, consequential, or incidental damages arising from the use or inability to use the product. Some state or provinces do not allow the exclusion or limitation of liability for consequential or incidental damages so the above limitation may not apply.

In the event repair or replacement are necessary, purchaser shall contact M2 for return authorization. In many cases this contact can simplify and expedite the repair / replacement process and help reduce costs and downtime.

The purchaser shall be responsible for packing the product properly for return and for charges to ship the product to **M2**. Always include with the shipment, a statement detailing the problem / failure and any other pertinent observations. Insuring the product for shipment is recommended. Use the original packing materials whenever possible. **M2** is responsible for charges (**in the United States**) to return the repaired / replacement product only where warranty service is involved.