

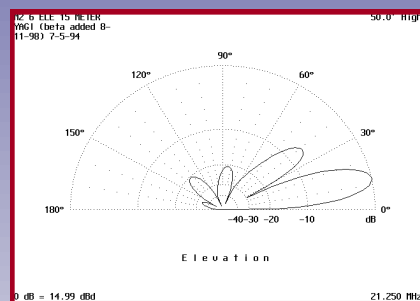

M2 Antenna Systems, Inc.

Model No: 15M6-125

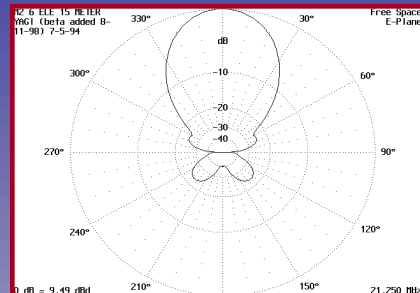
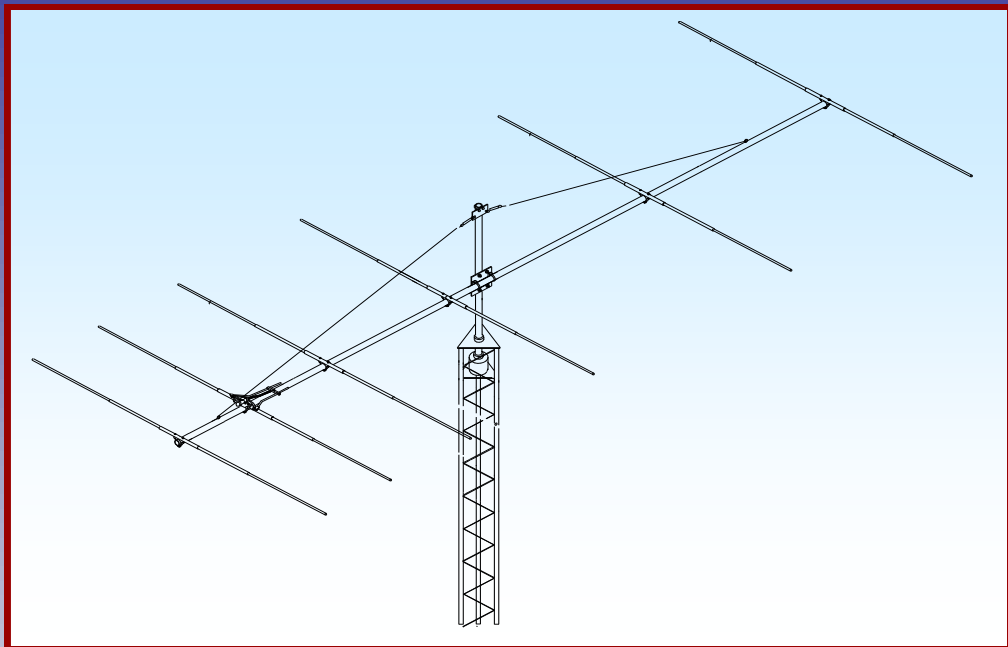

SPECIFICATIONS:

| | | | |
|-----------------------------|------------------------|----------------------------|--------------------------|
| Model | 15M6-125 | Boom Length / Dia | 44' 10" / 3" x .125 Wall |
| Frequency Range | 21.0 To 21.450 MHz | Element Length / Dia. | 24" / 1" To 1/2" |
| *Gain, (FS) / Over gnd..... | 11.3dBi / 17.1dBi @47' | Turning Radius: | 27' |
| Front to back..... | 23 dB Typical | Stacking Distance | 40' To 49' |
| Beamwidth | E=48° / H=53° | Mast Size | 2" to 3" Nom. |
| Feed type..... | Hair pin match | Wind area / Survival..... | 10.5 Sq. Ft. / 125 MPH |
| Feed Impedance..... | 50 Ohms Unbalanced | Weight / Ship Wt. | 115 Lbs. / 130 Lbs. |
| Maximum VSWR | 1.5:1 | | |
| Input Connector | SO-239, Others avl. | | |
| Power Handling | 3 kW, Higher avl. | | |

***Subtract 2.14 from dBi for dBd / FS = Free Space**

FEATURES:

The 15M6-125 is the perfect balance between wind area and performance. It features improved gain and F/B across the 15m band. Performance is excellent on both CW and phone. The 15M6-125 has been computer optimized for maximum strength for its wind area. The pattern is sharp and clean reducing noise and QRM. The 15M6-125 is a band opener and closer. It makes 100 watts sound like a kW! Mechanically, CNC machined aluminum (6061-T6) ring clamps ground the elements to the boom and make assembly a snap. A hairpin type match couples the 3kW 1:1 balun to the feedline. The antenna is completely DC grounded. Physically, the 15M6-125 features tapered elements, each secured with a pair of CNC machined, 1/2" thick aluminum boom-to-element plates secure each element and permit spacing adjustments on the 3" x .125" wall boom. Elements taper in size from 1" to the adjustable 1/2" tips and are single and double sleeved at critical points to achieve a 125MPH wind survival rating. All hardware, except U-bolts, is stainless steel. Great effort has been put into making sure this antenna stays in the air for years to come while providing enjoyment and satisfaction along the way.

M2 Antenna Systems, Inc. 4402 N. Selland Ave. Fresno, CA 93722
Tel: (559) 432-8873 Fax: (559) 432-3059 Web: www.m2inc.com

©2018 M2 Antenna Systems Incorporated

8/18/18
REV A

15M6-125 ASSEMBLY MANUAL

TOOLS REQUIRED: 11/32 NUT DRIVER, PHILLIPS HEAD SCREW DRIVER, 7/16, 1/2 AND 9/16" SOCKETS AND / OR END WRENCHES, KNIFE.

NOTE: Apply conductive paste or anti-seize compound (PENETROX OR NOALOX) lightly to all joints and electrical connections except the coax connectors.

Refer to the DIMENSION SHEET for details on boom assembly and element assembly.

1. Assemble the center section on each element EXCEPT THE DRIVEN ELEMENT by sliding two 1" x 60", "swaged one end" (SOE) tubes OVER the 7/8 x 48" center coupling tube. Secure with 8-32 x 1-1/2" screws and locknuts. For the DRIVEN ELEMENT, first slide on the two white polyethylene discs onto the 7/8 X 29-3/4" fiberglass center insulator near the center. Then slip the two special 1" x 60" tubes over the 7/8 x 29.75" fiberglass rod and align the 9/32 holes. insert (2) 1/4-20 x 2-1/4" bolts up through the holes and add (2) 3/8 clamp blocks to each side. Add the locknuts and finger tighten at this time.

2. Assemble the 3/4 x 36" SOE tubes to the 1/2" x (see DIMENSION SHEET) and (COMPRESSION CLAMP/TIP ASSEMBLY DETAIL) tubes in pairs and secure with 5/8" compression clamps. Be sure the driven element gets the right tip length pair. Now attach these tip sections to the center 1" sections using 8-32 x 1-1/4 screws and locknuts.

3. **FOR THE PARASITIC ELEMENTS**, attach a pair of element to boom clamps at the center of each 1" element section using (4) 1/4-20 x 2" bolts and locknuts. **FOR THE DRIVEN ELEMENT**, center the clamps over the 7/8 o.d. fiberglass center insulator. Tighten evenly so the clamp halves are parallel.

4. Assemble the boom by first sliding in the BOOM STIFFENER into the 3" x 15 ft. straight section per the dimensions sheet. Then insert the two 3" x 15' SOE tubes into the 3" x 15" straight section. Align the holes and secure with 1/4-20 x 3-1/2" bolts and locknuts. Tighten until no movement occurs at the joints.

5. Add the two 3/8 forged eyebolts and secure with 3/8 nuts.

6. Refer to the DIMENSION SHEET and install the elements on the boom at the correct spacing. Start with the REFLECTOR and place it about 3/8" in from the end of the boom. Add two saddles and secure with (4) 1/4-20 x 3" bolts with 1/4" split ring lockwashers under each bolt head. Align the reflector, on the top of the boom, perpendicular to the eyebolts and tighten the 4 bolts evenly. Continue with the rest of the elements.

7. Install the 1 x 1x 4" "L" bracket on the top of the DRIVEN ELEMENT CLAMP PLATES by removing the nuts from the upper set of clamp bolts. (These bolts should be 1/4-20 x 2-1/4") Place the bracket on top of the clamp block and re-install the two nuts. Attach the balun as shown on the DIMENSIONS SHEET. The main feedline MAY be attached at this time and secured along the boom using the heavy black nylon ties supplied. For long tie life, wrap a couple of layers of Scotch 33 black vinyl tape over the ties.

8. Attach the HAIRPIN assembly as shown on the DIMENSION SHEET and the HARDWARE ARRANGEMENT SHEET. Set the shorting bar to the dimension shown. A one or two inch longer setting will improve the match at the CW end and a one inch shorter setting will improve the match at the high end. Generally, the match will be under 1.5 : 1 across the

15M6-125 ASSEMBLY MANUAL

whole band for the dimension shown.

9. (THIS STEP MAY VARY DEPENDING ON MAST OR TOWER TYPE). Locate the balance point of the boom and attach the boom to mast plate using two 3" U-bolts and saddles. Secure with (2) stainless 3/8-16 nuts and lockwashers for each U-bolt. Temporarily install two of the 2" heavy duty U-bolts and attach a temporary mast. Install the single 2" regular U-bolt and 2 x 5" turnbuckle plate up about 5 feet on the temporary mast. Open the two forged turnbuckles until just one thread shows inside the body of the turnbuckle. Attach the turnbuckles to the turnbuckle plate.

10. Unroll the HPTG 4000 Phyllistran guy cable and attach one end to each eyebolt using two 1/4 clips and a 1/4 cable eye. Return to the temporary mast and cut the guy cable so you have at least 12 inches remaining after the cable passes through the eye of the turnbuckle. Install a cable eye in each turnbuckle eye and attach the cable using two cable clips on each side as on the eyebolts. Tension the cables evenly with the turnbuckles so the boom is level. Remove the temporary mast. The antenna is now ready to be installed on the tower.

NOTE: Whenever possible let the antenna sit overnight to allow the hardware to take a "set". Go over the dimensions one more time. Then re-tighten all the screw and bolt connections one more time.

CAREFULLY DESIGNED AND MANUFACTURED BY:

M² ANTENNA SYSTEMS, INC.

4402 N. SELLAND AVE.

FRESNO, CA 93722

(559) 432-8873 FAX: 432-3059

www.m2inc.com Email: sales@m2inc.com

15M6-125 ASSEMBLY DETAILS

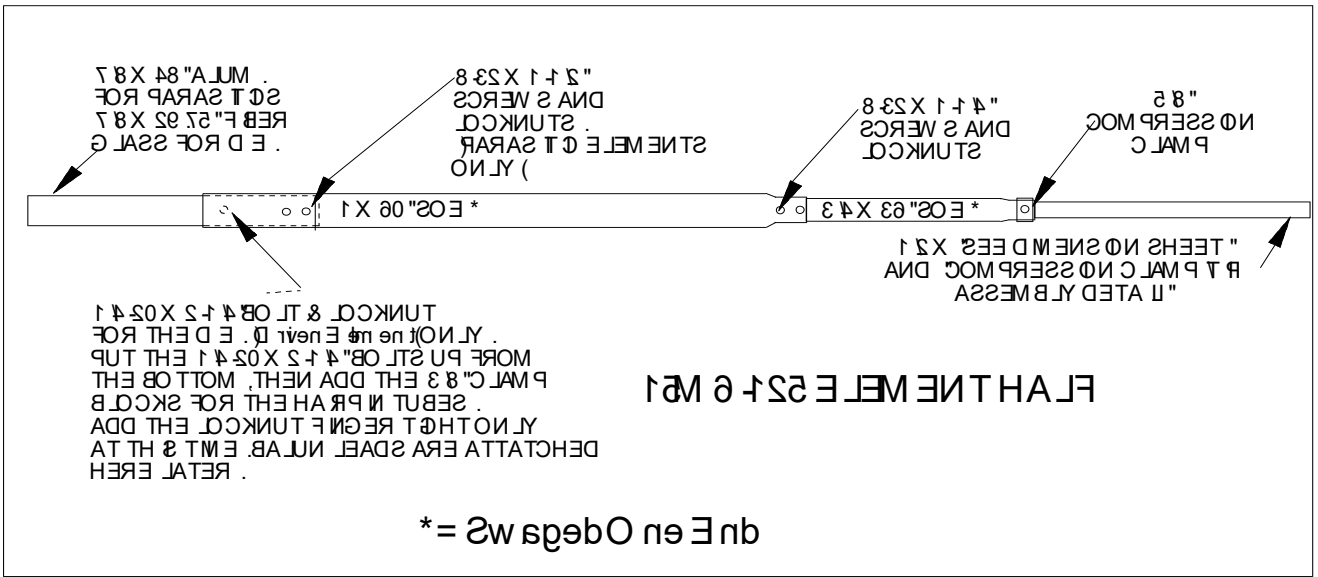
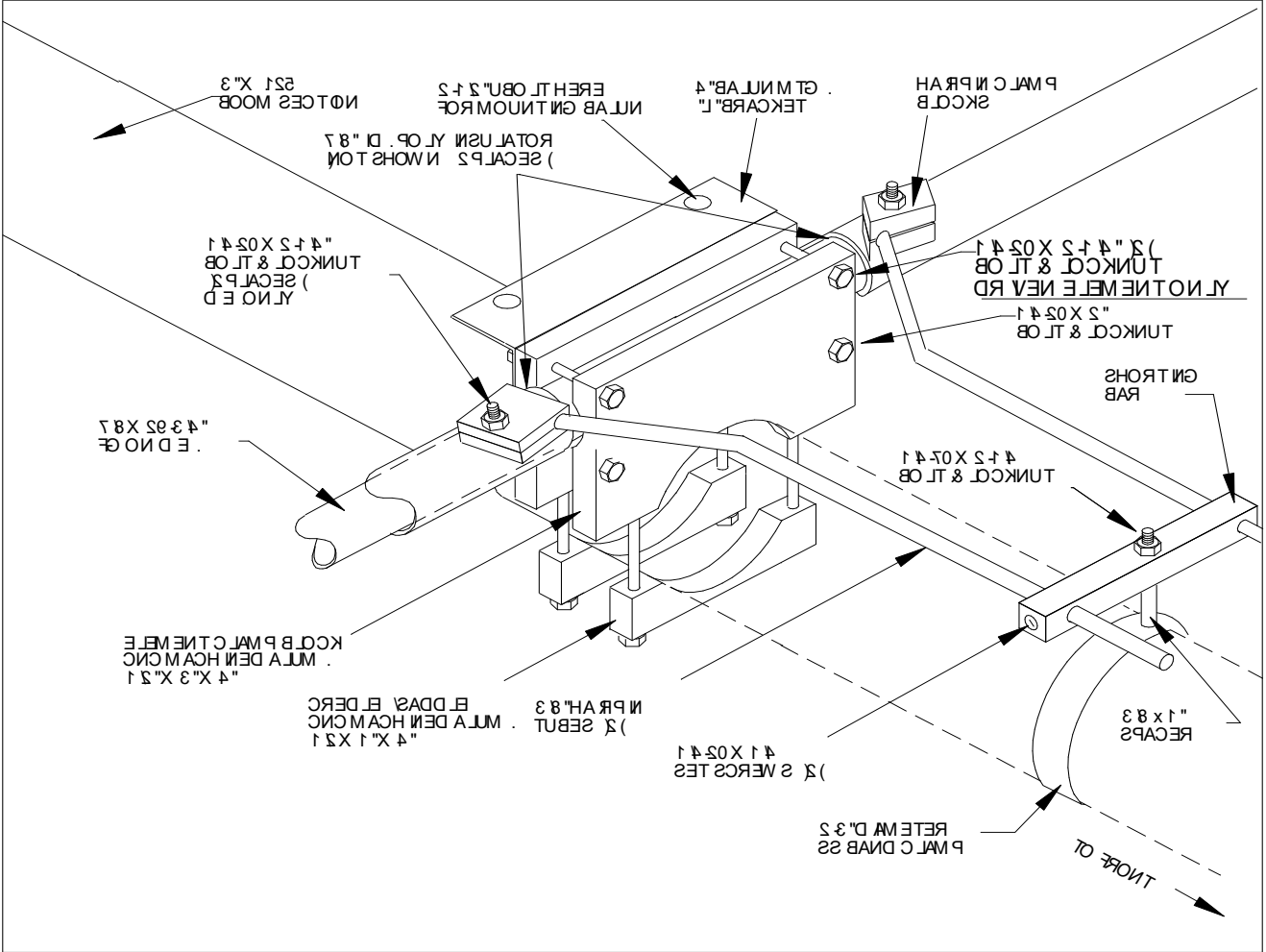

dn E en Odegs W2 = *

GENERIC COMPRESSION CLAMP DETAIL

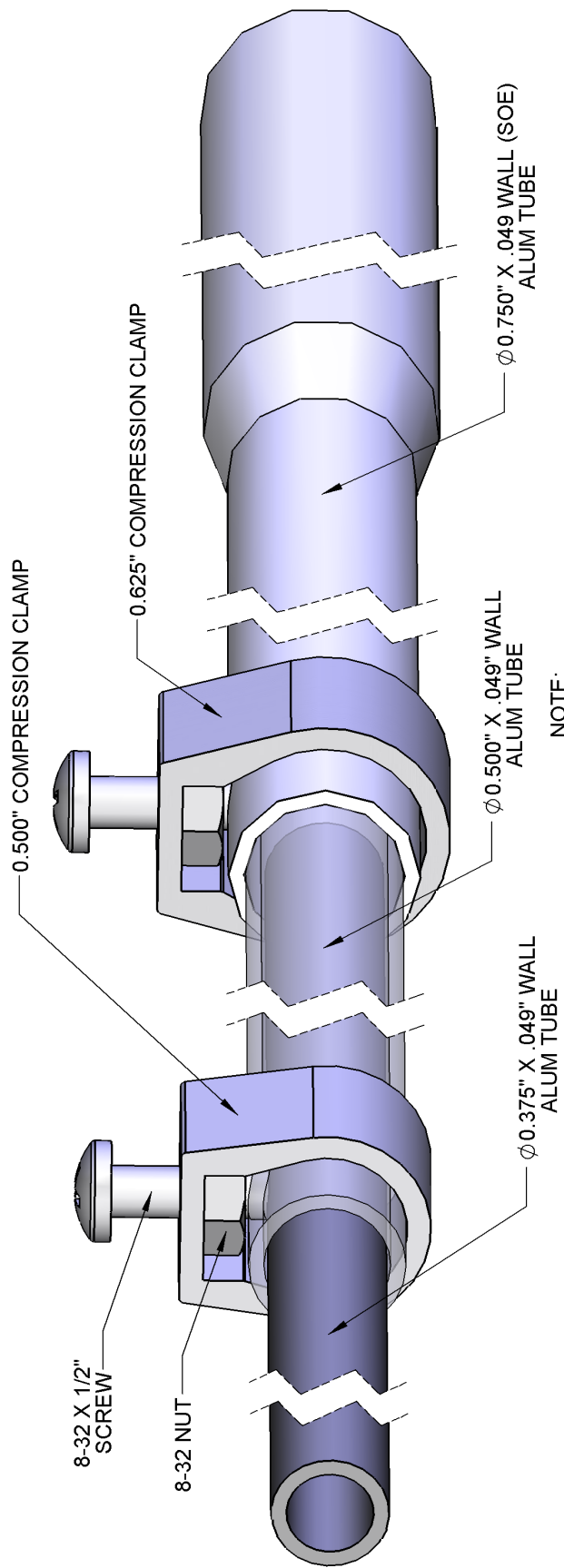

NOTE:
TUBES SHOWN TRANSPARENT
TO SHOW MORE DETAIL

NOTE:
Generic layout to show
how compression clamps work.
Your antenna may have one or the other
or may even have both compression
clamp sizes.

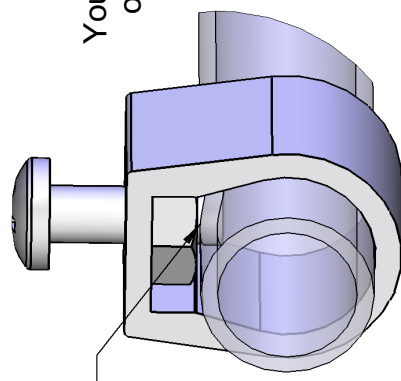

NOTE: INSIDE TUBE NOT SHOWN FOR CLARITY

15M6-125 PARTS & HARDWARE

| DESCRIPTION | Qty |
|--|-----|
| BOOM SEC 3.0 X .125 X 180"..... | 1 |
| BOOM SEC 3.0 X .125 X 180" S.O.E..... | 2 |
| BOOM STIFFENER 2-1/2 X 120" W / 1" COUPLING RINGS..... | 1 |
| ELEMENT SLEEVE 7/8 X .058 X 48"..... | 5 |
| ELEMENT SEC. 1.0 X .058 X 60"..... | 10 |
| ELEMENT SEC. 1.0 X .058 X 60 (DRIVEN ELEMENT)..... | 2 |
| ELEMENT SEC. 3/4 X .058 X 36"..... | 12 |
| ELEMENT TIPS 1/2 X .049 X SEE DIM. SHEET..... | 12 |
| BOOM TO MAST PLATE 8.0 X 8.0 X .250..... | 1 |
| HAIRPIN PARTS | |
| FIBERGLASS ROD ,7/8 X 29-3/4"..... | 1 |
| TUBE, HAIRPIN, 3/8 X 30"..... | 2 |
| BALUN, 1:1, 3-30 MHz STANDARD..... | 1 |
| HAIRPIN PARTS BAG | |
| SHORTING BAR, HAIRPIN 1/2 X 1/2 X 5"..... | 1 |
| CLAMP BLOCK, HAIRPIN,..... | 4 |
| SPACER, 3/8" X 1"..... | 1 |
| POLY DISC, 7/8" HOLE..... | 2 |
| 'L' BRACKET, BALUN MTG, 1 X 1 X 4"..... | 1 |
| BAND CLAMP 3-1/2" MODIFIED..... | 1 |
| U-BOLT 2-1/2" (BALUN MTG.)..... | 1 |
| NUT, 5/16-18 SS..... | 2 |
| LOCKWASHER, 5/16" SPLIT RING SS..... | 2 |
| BOLT, 1/4-20 X 2-1/4..... | 1 |
| LOCKNUT, 1/4-20 NYLOC..... | 1 |
| SET SCREW 1/4-20 X 1/4" SS..... | 2 |
| ALLEN WRENCH 1/8"..... | 1 |
| TURNBUCKLE PLATE, 2 X 5..... | 1 |
| EYE BOLT 3/8 X 6", FORGED..... | 2 |
| HF ELEMENT CLAMPS, 4"..... | 12 |
| 3" SADDLE CLAMP,..... | 12 |
| TURN BUCKLES 3/8 X 8, EYE & JAW, FORGED..... | 2 |
| HPTG 4000, (40')..... | 1 |
| U-BOLT 2" STANDARD (for turnbuckle plate)..... | 1 |
| U-BOLT 2" HD..... | 4 |
| U-BOLT 3"..... | 2 |
| 5/8" COMPRESSION CLAMP..... | 12 |
| 1/4" CLIPS, GALV. (for guy cable)..... | 8 |
| HARDWARE BAG | |
| 8-23 X 1-1/2" SCREW, SS..... | 20 |
| 8-32 X 1 1/4 SCREW SS..... | 24 |
| 8-32 X 1/2" SCREW SS..... | 12 |
| 8-32 NYLOC NUT SS..... | 44 |
| 8-32 NUT SS..... | 12 |
| BOLT 1/4-20 X 3 1/2 SS..... | 4 |
| BOLT 1/4-20 X 3" SS..... | 24 |
| BOLT 1/4-20 X 2-1/4" SS..... | 4 |
| BOLT 1/4-20 X 2 SS..... | 22 |
| NUT, NYLOC 1/4-20 SS..... | 30 |
| LOCKWASHER, 1/4" SPLIT RING,SS..... | 24 |
| NUT, 5/16-18 SS (for standard 2" U-BOLT..... | 2 |
| LOCKWASHER, 5/16", SPLIT RING SS..... | 2 |
| NUT, 3/8-16 SS..... | 14 |
| LOCKWASHER 3/8 SPLIT RING, SS..... | 14 |
| THIMBLE, 1/4" (for guy cable)..... | 4 |
| NYLON TIES 14"..... | 6 |
| CONDUCTIVE PASTE, CUP..... | 1 |

M² ANTENNA SYSTEMS, INC.
 4402 N. SELLAND AVE.
 FRESNO, CA 93722
 (559) 432-8873 FAX: 432-3059
 www.m2inc.com Email: sales@m2inc.com