

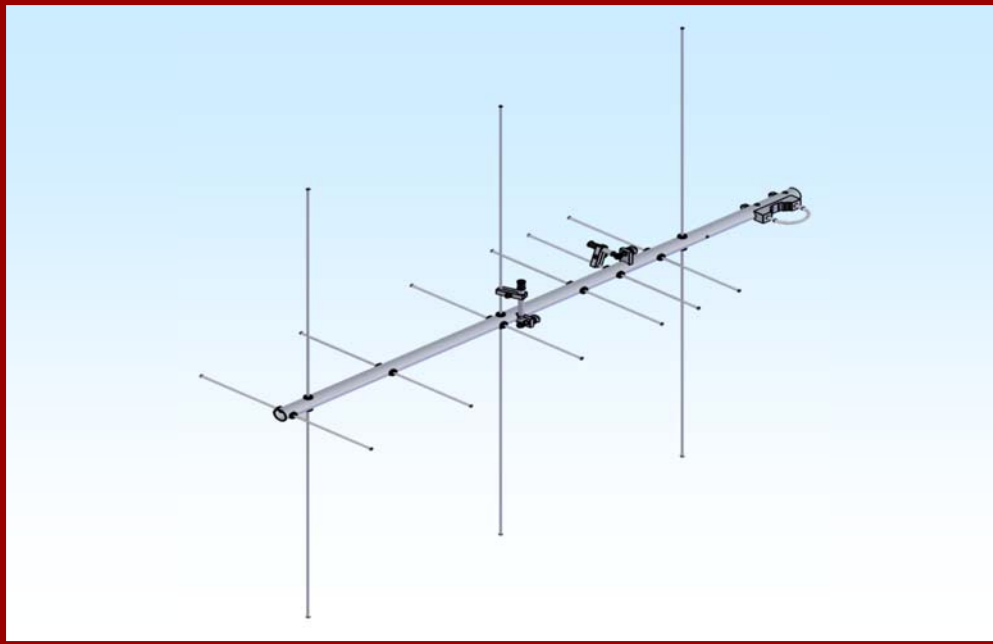

M2 Antenna Systems, Inc. Model No: 2M-440XPSS



SPECIFICATIONS:

Model	2M-440XPSS	Boom Length / Dia.....	41-1/4" / 1"
Frequency Range.....	144-148 / 420-450 MHz	Maximum Element Length.....	40"
*Gain 2M / 440	8.3 / 11 dBi	Turning Radius	42"
Front to back 2M / 440	20 dB / 18 dB	Stacking Distance.....	Call Factory
Feed Impedance.	50 Ohms Unbalanced	Mast Size.....	1-1/2" to 2" Nom.
VSWR.....	1.5:1	Wind area / Survival	0.31 Sq. Ft. / 75 MPH
Connectors	SO-239	Weight / Ship Wt.....	2 Lbs. / 5 Lbs.
Power Handling 2M / 440	500W / 500W		

***Subtract 2.14 from dBi for dBd**

FEATURES:

The 2M-440XPS is ideal for linking repeaters and remote bases utilizing both 2 meters and 440 MHz. Elements are cross polarized to avoid the severe performance compromises on 440 MHz common to other dual band antennas that have all elements in the same polarity. The XP also works well on the OSCAR frequencies and is handy wherever dual band capability and compact size are required. Recently, with PACKET users finding horizontal polarization better on 2 meters, it has become even more useful.

Construction is designed for long term mechanical and electrical integrity. Elements are 3/16" 6061-T6 aluminum rod, centered through the boom on UV stabilized insulator buttons. All hardware is stainless steel.

2M-440XPSS ASSEMBLY MANUAL

Tools handy for assembly process: Phillips head screwdriver, 5/16", 11/32" spin-tight or socket, 7/16" end wrenches / sockets, measuring tape. (**Note: Repeat Steps 1—15 for both antennas.**)

1. This antenna uses a one-piece boom that will be rear mounted.
2. Lay out the elements by length and position as shown on the **DIMENSION** sheet. Start with the reflector (longest) element and push on a black button insulator to about 1/2" from the center of the element. Push the reflector element through the element hole towards the rear of the boom. (Refer to the **DIMENSION** sheet for proper placement) Install the second button insulator on the other side of the element, pushing it up into boom. **DO NOT BOTHER WITH ACCURATELY CENTERING** the element at this time and **DO NOT INSTALL** the stainless steel internal locking keepers yet. This is easier to do after all of the elements are installed in the boom.
3. Install the **DRIVEN ELEMENT** in the same way as you did the reflector element. Then continue with the installation of the **DIRECTOR or DIRECTORS**.
4. Now begin centering the elements. Use a tape measure to **EQUALIZE** the amount of each element sticking out on each side of the boom. Once you have all of the elements centered, sight down the element tips from the rear comparing each side. Look for any obvious discrepancies and correct if found.

5. Install the stainless steel keepers to secure the elements. **NOTE:** For portable or temporary use of the antenna, the keepers may be left off. The button insulators, (normally a tight fit) hold the elements quite securely.

To install, use thumb and forefinger to hold the keeper over the end of the **PUSH TUBE**. Make sure that the internal fingers of the keeper are dished into the push tube. **HOLD THE ELEMENT FIRMLY TO PREVENT IT FROM SLIDING OFF CENTER** and press the keeper onto the element end and continue until the keeper is snug on the insulator button.



Locking pliers, *lightly* clamped up against the opposite button insulator, will help maintain center reference. If you push the first keeper too far, remove the element from the boom, push the keeper completely off the element, and start over. Install another keeper to the opposite side of the element. Continue installing keepers until all elements are locked in place.

6. Next, assemble the Gamma Match assembly. Start by sliding a #6 flat washer over the end of the Gamma Feed block stud.
7. Slide the Gamma Insulator over the Gamma Rod, leaving 1/8" of the insulator exposed beyond the end of the Gamma Rod. Slide this Gamma Rod and Insulator over the end of the Gamma Feed block stud.

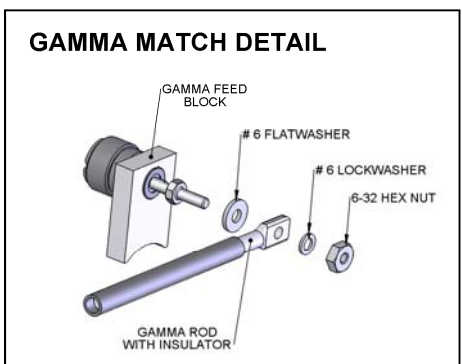

8. Now, slide a #6 lock washer over the Gamma Feed block stud and finish the assembly with a 6-32 nut. ***Note*** The connector stud can spin freely. Use a pair of needle nose pliers or a small wrench to hold the flat surface when tightening.
9. Next, attached the Gamma Match assembly to the boom, using a single 8-32 x 1 1/4" screw. Make sure to orient the Feed connector towards the rear of the antenna.
10. Now slide the Gamma Tube over the Gamma Insulator and refer to the **DIMENSION** sheet for proper placement.

2M-440XPSS ASSEMBLY MANUAL

11. Install the two halves of the Shorting Bar onto the Gamma Tube and the driven element below. Refer to the **DIMENSION** sheet for proper location of the shorting bar. Tighten the shorting bar in place using a single 8-32 x 7/8" screw and lock nut.
12. Now Slide the 3/8" x 1/2" Vinyl cap over the Gamma Tube until it is flush with the end of the Gamma Tube.
13. At this point it is important to determine whether your antenna will be mounted horizontally (**SSB/CW**) or Vertically (**FM**). Locate the two sets of holes at the rear of the antenna.
14. Insert the 2" u-bolt into the uni-cradle and slide this assembly into one of the two sets of holes on the rear of the boom. Finish the assembly by installing (2) 1/4" lock washers and 1/4-20 nuts.
15. **MOUNTING FOR HORIZONTAL OR VERTICAL POLARIZATION**
Route the feed line coax towards the rear of the antenna past the reflector element and onto your mast. Secure the feed line coax to the antenna boom with the supplied nylon ties. **When mounting the antenna vertically polarized, make sure to orient the gamma tube with the vinyl cap facing up.**

To maintain good VSWR and antenna pattern: Keep metallic masts, cross booms and the feed line coax out of the element plane.

Stacking or Phasing ? Call us and let us help you DO IT RIGHT.

THIS COMPLETES THE ANTENNA ASSEMBLY.

Carefully manufactured by:

M² ANTENNA SYSTEMS, INC.

4402 N. Selland Ave.

Fresno, CA 93722

(559) 432-8873 Fax: 432-3059

www.m2inc.com Email: sales@m2inc.com

2M3-SS DIMENSION SHEET

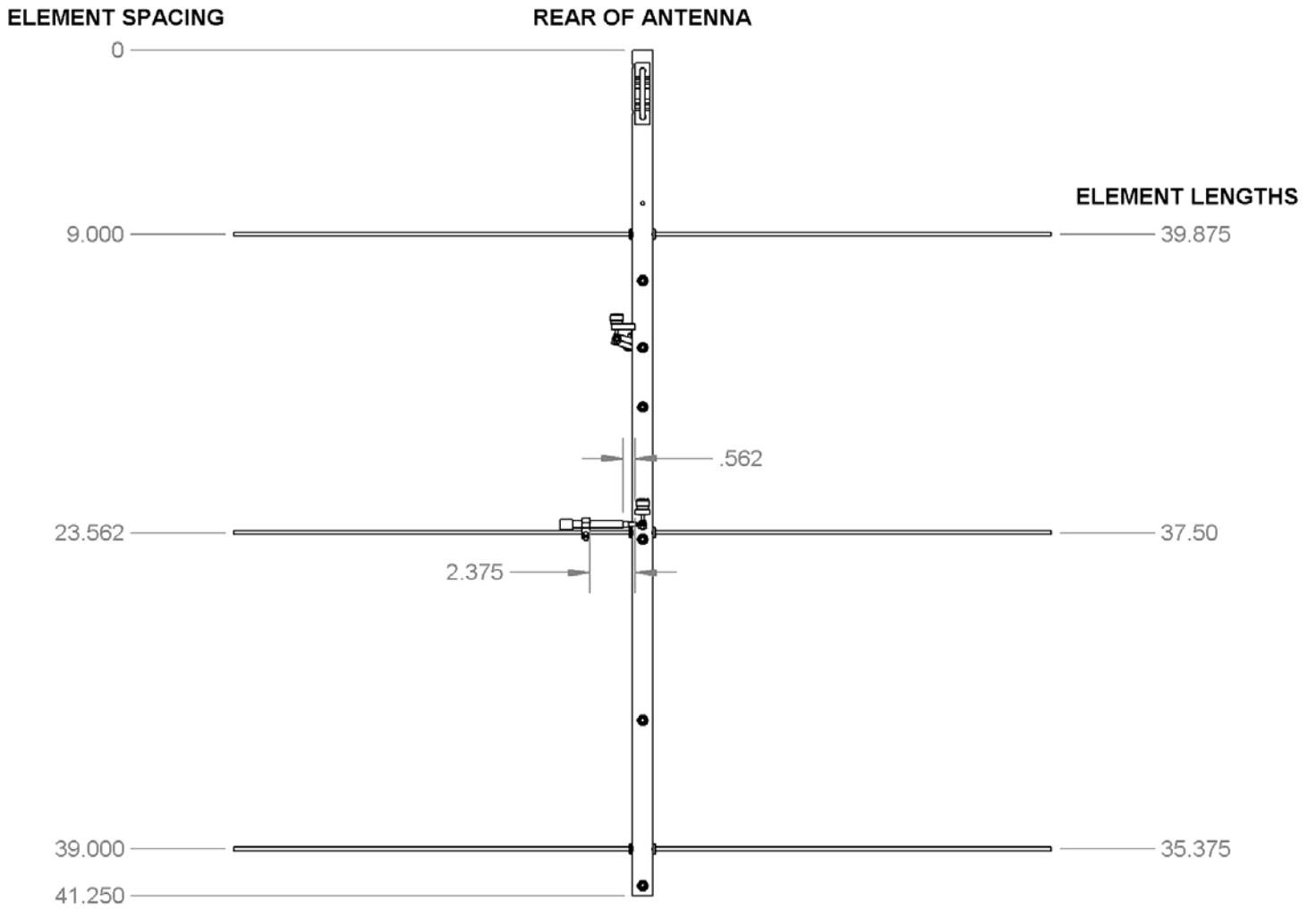

440-6SS DIMENSION SHEET

ELEMENT SPACING

REAR OF ANTENNA

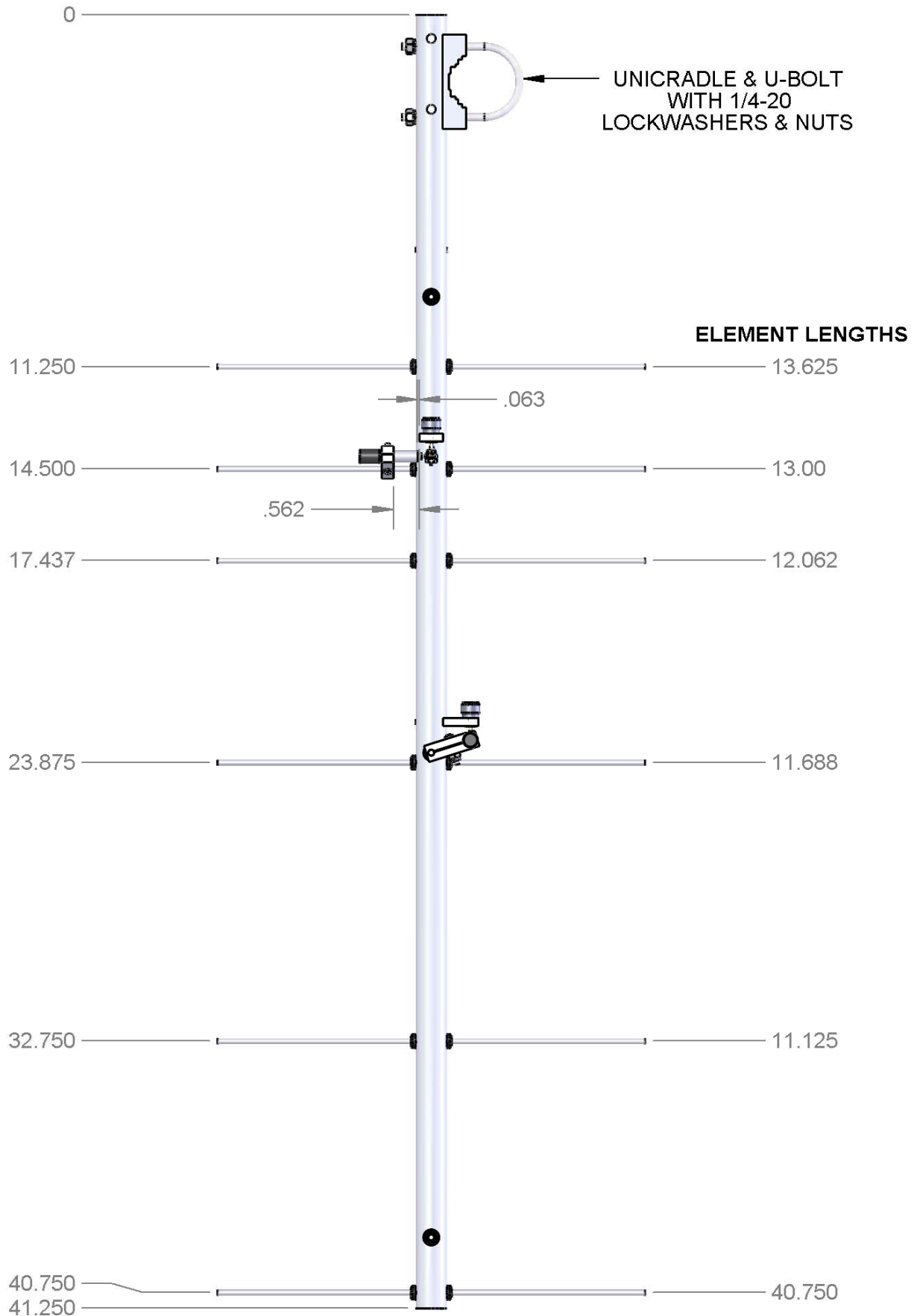

GAMMA MATCH PARTS & HARDWARE

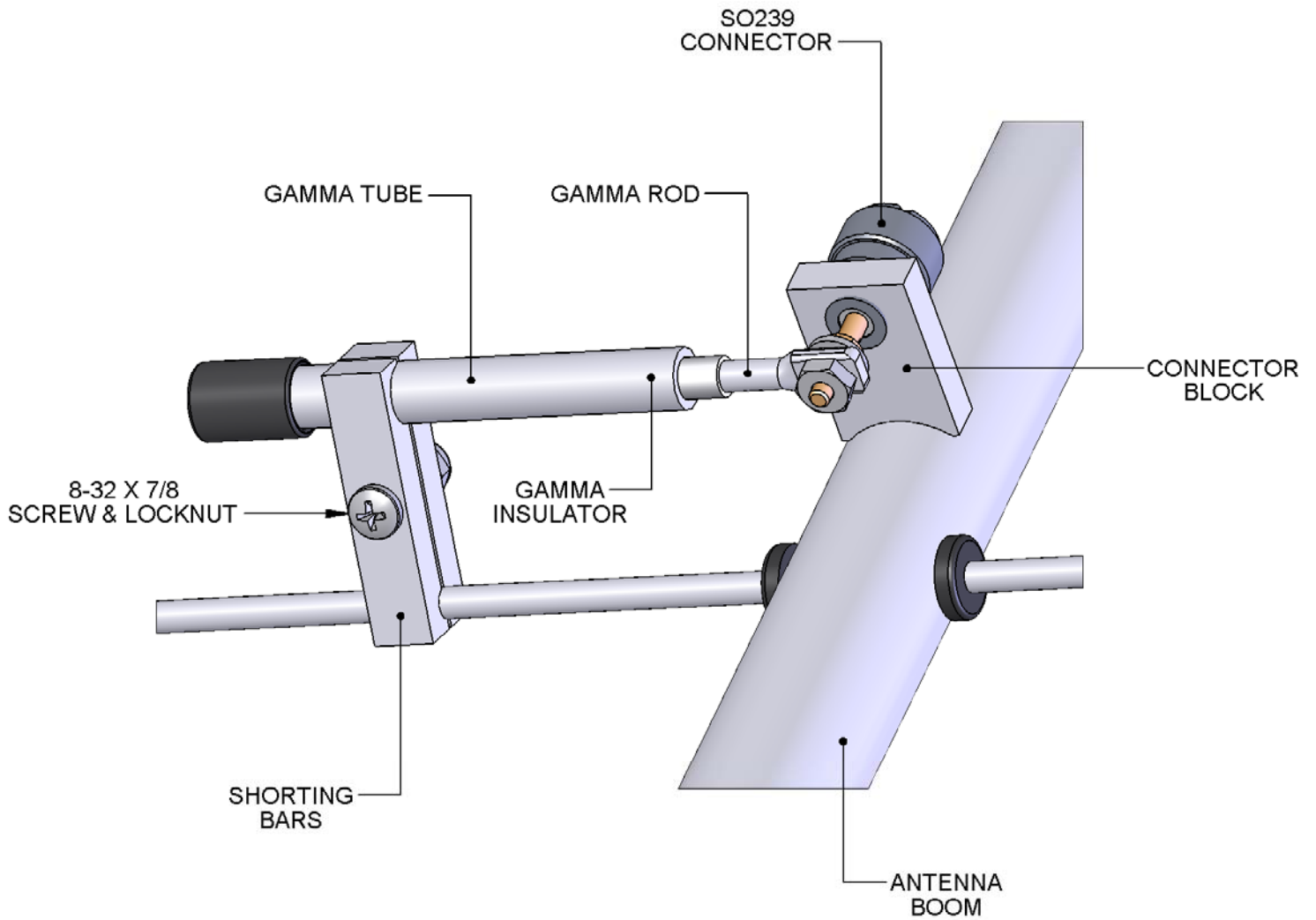

2M-440XPSS PARTS & HARDWARE

DESCRIPTION	QTY
BOOM SECTION, 1 X .058 X 41-1/4"	1
2M ELEMENTS, 3/16 ROD X SEE DIM SHEET	3
2M GAMMA ROD, 3/16 X 3.25 ALUM ROD	1
2M GAMMA TUBE, 3/8 X .058 X 3.00 ALUM TUBE	1
2M GAMMA INSULATOR, 1/4" X .031 X 2.50 TEFLON.....	1
440 ELEMENTS, 3/16 ROD X SEE DIM SHEET	6
440 GAMMA ROD, 3/16 X 2.0 ALUM ROD	1
440 GAMMA TUBE, 3/8 X .058 X 1.75 ALUM TUBE.....	1
440 GAMMA INSULATOR, 1/4" X .031 X 1.625 TEFLON.....	1
GAMMA CONNECTOR BLOCK ASSEMBLY.....	2
VINYL CAP, 3/8" X 1/2"	2
UNI CRADLE	1
U-BOLT, 2" SS	1
HANDLE GRIP	1
ASSEMBLY MANUAL	1

HARDWARE BAG:

SHORTING BAR, 1/4 X 3/8 X 1.688.....	4
BUTTON INSULATORS, 3/16	18
KEEPERS, 3/16 SS	18
SCREW, 8-32 X 1.25 SS	2
SCREW, 8-32 X .875 SS	2
LOCKNUT, 8-32 SS.....	2
FLATWASHER, #6 SS	2
LOCKWASHER, #6 SS	2
NUT, 6-32 SS	2
LOCKWASHER, 1/4 SS	2
NUT, 1/4-20 SS	2
NYLON TIE, (MEDIUM)	6
PUSH TUBE, 3/8 X 3".....	1

M² ANTENNA SYSTEMS, INC.

4402 N. Selland Ave.

Fresno, CA 93722

(559) 432-8873 Fax: 432-3059

www.m2inc.com Email: sales@m2inc.com