

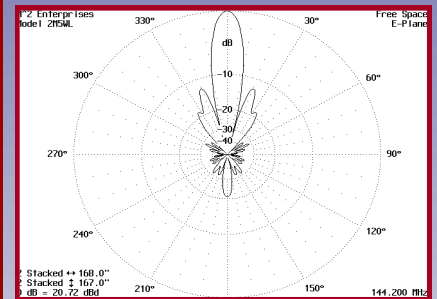

M2 Antenna Systems, Inc.

Model No: 2M5WL

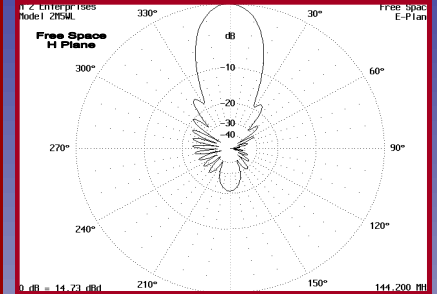
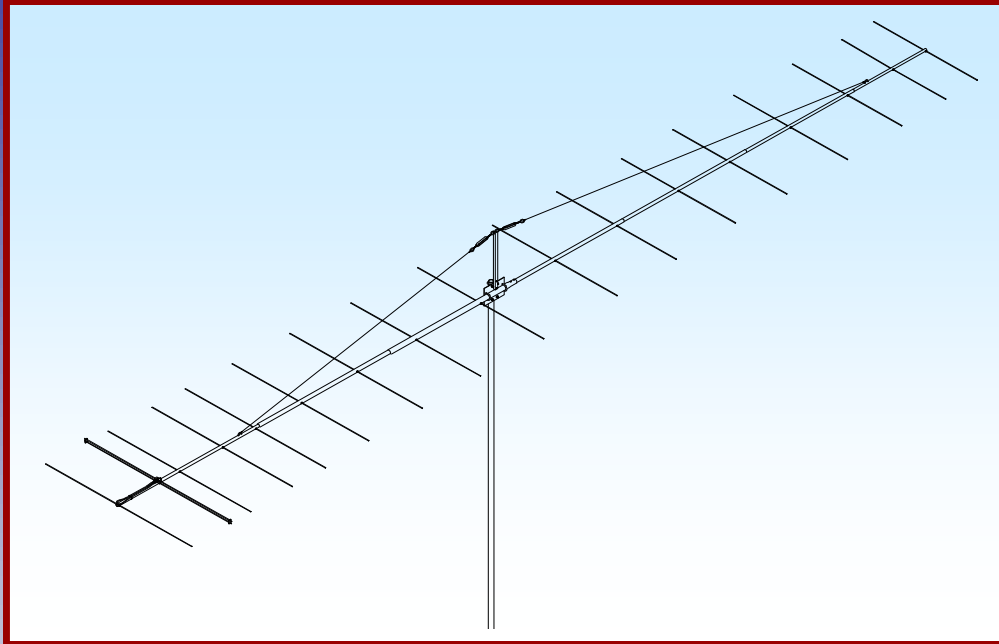

SPECIFICATIONS:

Model	2M5WL	Power Handling	1.5 kW
Frequency Range	144 To 148 MHz	Boom Length / Dia	33' / 1-1/2" to 3/4"
*Gain	16.84 dBi	Maximum Element Length	40-5/8"
Front to back	22 dB Typical	Turning Radius:	18' 9"
Beamwidth	E=26° H=29°	Stacking Distance	14' High & 14' Wide
Feed type	"T" Match	Mast Size	2" Nom.
Feed Impedance	50 Ohms Unbalanced	Wind area / Survival	2.7 Sq. Ft. / 100 MPH
Maximum VSWR	1.2:1	Weight / Ship Wt.	13 Lbs. / 14 Lbs.
Input Connector	"N" Female		

***Subtract 2.14 from dBi for dBd**

FEATURES:

The **2M5WL** is designed with the **SERIOUS "Weak Signal"** enthusiast in mind. It provides excellent gain for minimum weight and wind load yet is strong enough to survive 100+ mph winds. The modified folded dipole driven element is also unique as it's center is a CNC machined block of aluminum fitted with 'O' ringed connectors and access cap. After factory assembly, the block is filled with a space age silicone gel which further seals and increases dielectric breakdown and arc-over protection. The 3/16" rod elements mount through the boom on UV stabilized button insulators. All hardware is stainless steel except for U-bolts. A vertical riser and an overhead Dacron cord guy system is supplied for boom support. This antenna is widely used in **EME** (W5UN's 48 2M5WL's and many others) and large Tropo scatter arrays. Several optional items are available to provide more gain from your 2M5WL's. 2 and 4 port power dividers are available for matching stacks of 2 or 4 antennas. 50 Ohm phasing lines model VHF-50-2M5WL2 and VHF-50-2M5WL4 can be ordered for phasing 2 or 4 antennas together. 'H' frames, OR-2800 and MT-3000 AZ and EL rotators are also available as well as Rohn and US towers.

2M5WL ASSEMBLY MANUAL

1. Start by laying out the boom sections using the DIMENSION sheet as a guide. Use 8-32 X 1-1/4 screws and locknuts to join 3/4" to 1" sections; 1-1/2" screws for 1" to 1-1/4" sections; 1-3/4" screws for 1-1/4" to 1-1/2" and 1-1/2" to 1-1/2" sections.
To make assembly easier, support the boom about waist high on bucks, tables, etc. Or, drive a 1-1/2" to 2" pipe into the ground and temporarily attach boom using boom to mast plate and U-bolts at balance point.
2. Lay out the elements by length and position as shown the DIMENSION sheet. Start with the reflector (longest) element. Balance across finger to find center and push on a black button insulator to about 1/2" from center. Push the element through the holes 1/2" from the rear of the boom and install the second button, snugging it up into boom. **DO NOT BOTHER WITH ACCURATELY CENTERING** the element at this time and **DO NOT INSTALL** the stainless steel internal locking shaft retainers yet. This is easier to do after all the elements are installed in the boom.
3. Install the 3/16" rod DRIVEN ELEMENT as you did the reflector. Then continue with the installation of the DIRECTORS. **Note that the Director Elements do not consistently diminish in length from rear to front, so pay close attention to length and position.**
4. Now begin centering the elements. Use a tape measure to EQUALIZE the amount the element sticking out on each side of the boom. Once you have all the elements centered, sight down the element tips from the rear comparing each side. Look for any obvious discrepancies and correct if found.
5. NOTE: The SHAFT RETAINERS should always be used to secure the elements for permanent and long term antenna installations. However, for portable or temporary use, or whenever it is anticipated that the antenna will be disassembled within a short time, the retainers may be left off. The button insulators, normally a tight fit, will hold the elements quite securely.
To install the stainless steel element SHAFT RETAINERS, start by using thumb and forefinger to hold the retainer against the end of the PUSH TUBE (3/8 x 3" push tube, supplied in the kit), internal fingers on retainer dished into tube. **HOLD THE ELEMENT FIRMLY TO PREVENT IT FROM SLIDING OFF CENTER** and press the retainer onto the element end and continue until retainer butts on insulator button (Locking pliers, **lightly** clamped up against opposite button insulator will help maintain center reference. If you push the first retainer too far, remove element from boom and push retainer completely off the element). Now repeat for the other side of the element. Continue installing retainers until all elements are locked in place.
6. Mount the DRIVEN ELEMENT BLOCK ASSEMBLY to the top of the boom using a single 8-32 X 1-1/4" screw. Orient the block with feed connector facing to center and balun connectors facing to rear. Block orientation may be reversed if you wish feedline to exit from rear of boom.
7. Before installing the balun, thread a 3/8" SEAL NUT all the way onto each connector, with the black Neoprene face out. Attach balun to the Block and tighten the connectors **gently** using a 7/16" end wrench. Once the connectors are tight, back the Seal Nuts out and finger-tighten firmly up against the face of the connectors (or tighten **gently** with 1/2" end wrench). A lot of torque is unnecessary. Form the balun close to the boom and secure to boom with a nylon cable tie. Tie should be snug but not crushing or kinking the coax.
8. Install the 8-32 x 1/4" set screws (internal Allen head - tool supplied) into the SHORTING BARS. Slide the bars onto the 3/16" rod driven element tips and then onto the Driven Element Block Rods. Position the Shorting Bars at the very ends of the 3/16" rod (through the boom). Align the bars and rods with each other and tighten the set screws.
9. Attach the square 18" RISER TUBE to the boom-to-mast plate using two 8-32 x 1-1/4" screws and locknuts. The large holes at the top of the riser are slightly off-center and should be oriented away from the boom-to-mast plate and closer to the centerline of the boom.

2M5WL DIMENSION SHEET

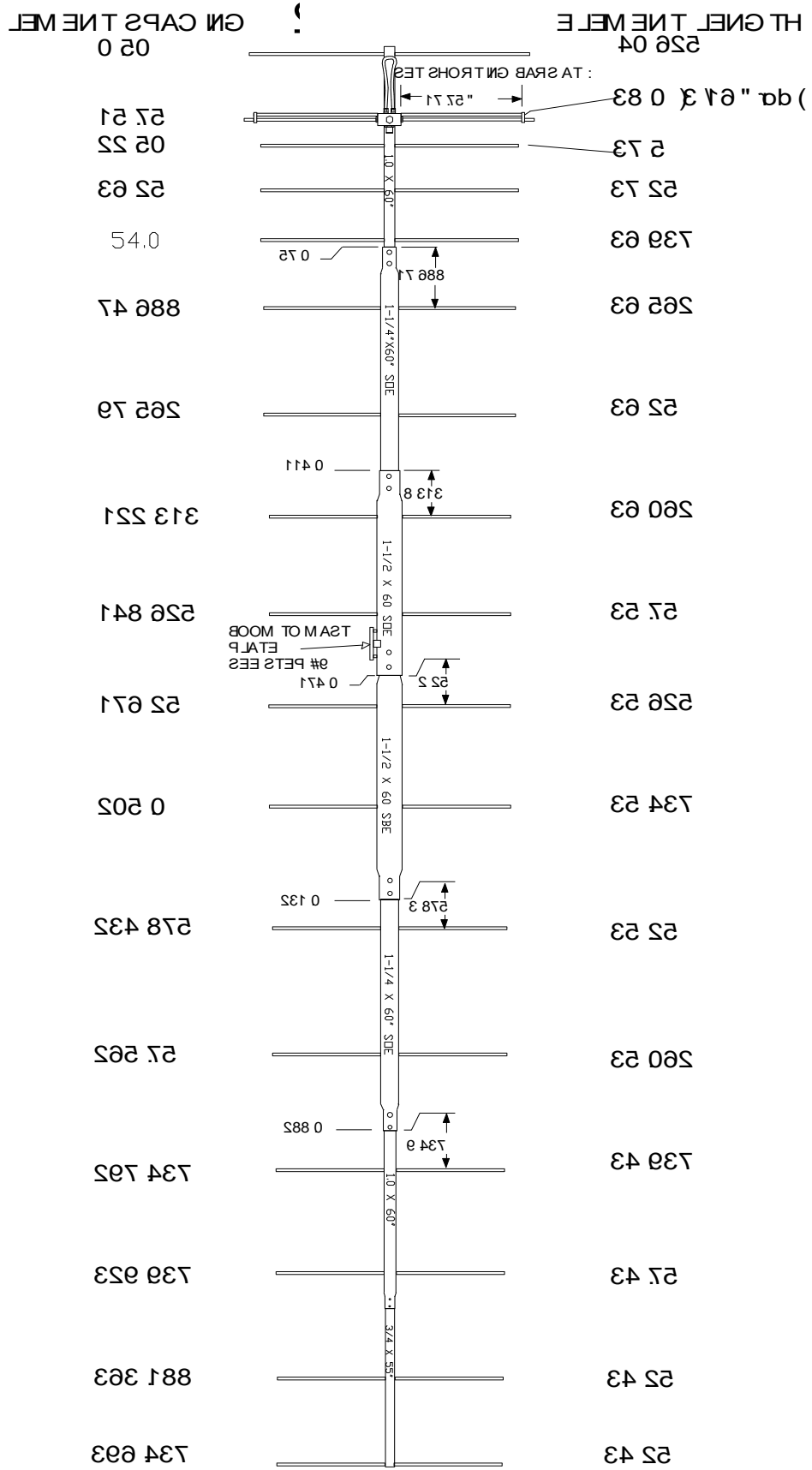

NO SREVNOIC NOTCARF OT LAMCED	
01 = 280	
02 = 251	
03 = 881	
04 = 022	
05 = 212	
06 = 272	
07 = 234	
08 = 002	
09 = 252	
10 = 228	
11 = 888	
12 = 022	
13 = 218	
14 = 278	
15 = 238	

2M5WL ASSEMBLY MANUAL

10. The boom to mast plate is normally mounted at the balance point, about 13' 2" from rear of boom. Use two 1-1/2" U-bolts and the stainless nuts and lock washers provided. DO NOT OVER TIGHTEN. 2" U-bolts are provided for mounting the antenna to your mast. Since the feed line represents significant weight it is best to have it attached and fastened along the boom with cable ties before final mounting the plate.
11. Refer to Boom support drawing. Install the two small "U" shaped rods into the top side of the boom. Secure with SHAFT RETAINERS.
12. Install the two turnbuckles into the top of the riser with open ends of the hooks "UP". Adjust threads until just one or two show inside turnbuckle body. Adjust the boom with supports until the middle is 4" to 6" LOWER than the ends. Attach one end of the Dacron cord to the rear eye bolt by taking two wraps through the eye and finishing with two half-hitches or a square knot. Adjust to leave 2" to 4" of cord after knots. Attach the other end of the cord to the front eye bolt in the same way. Equalize excess cord at the riser tube and cut. Take rear cord end and make two wraps through rear turnbuckle eye, then pull line taut and knot as above. Repeat for front cord and turnbuckle.
13. Now support antenna at the boom-to-mast plate. This tensions the cord and helps the knots to take a set. If possible, let this process extend overnight. Then adjust turnbuckles so boom ends bow up slightly (and equally). A few days on the mast should leave the boom straight. Cut excess lengths from cord, leaving 2" to 4". To prevent fraying melt ends with heat or flame and tape back to main line.

THIS COMPLETES THE ANTENNA ASSEMBLY.

INSTALLATION AND STACKING INFORMATION

A. Always use high quality coax and connectors, as old, corroded, or poor quality materials are common sources of performance degradation and failure.

B. If possible, test the antenna, connectors and feed line BEFORE installing to your mast or tower. At 6 feet or more the antenna will exhibit VSWR *similar* to higher mounting heights. Set antenna on a ladder or temporary mast. Check for continuity and match across the band. It should be 1.5:1 or better from 144 to 146 MHz and then rise to about 2:1 at 148 MHz. Remember, the 2M5WL is tailored for the lower half of two meters where horizontal polarity and sideband / CW are the common modes.

C. STACKING REMINDERS:

1. All driven element blocks MUST be oriented to the same side of boom.
2. All boom-to-mast plates MUST be mounted at the same point on the boom.
3. Feed / phasing lines MUST be of equal electrical length or multiples of 1 wavelength in order to maintain equal phasing in the array. Improper phasing can severely deteriorate performance.

If you are unsure about stacking multiple antennas, please call **M²** and let us help you DO IT RIGHT

CAREFULLY MANUFACTURED BY:

M² ANTENNA SYSTEMS INC.

4402 N. Selland Ave.

FRESNO, CA 93722

(559) 432-8873 FAX (559) 432-3059 Web:www.m2inc.com Email:sales@m2inc.com

2M5WL D.E. & OVERHEAD DETAIL

TYPICAL 2 METER
HARDWARE
ARRANGEMENT

NO SCALE

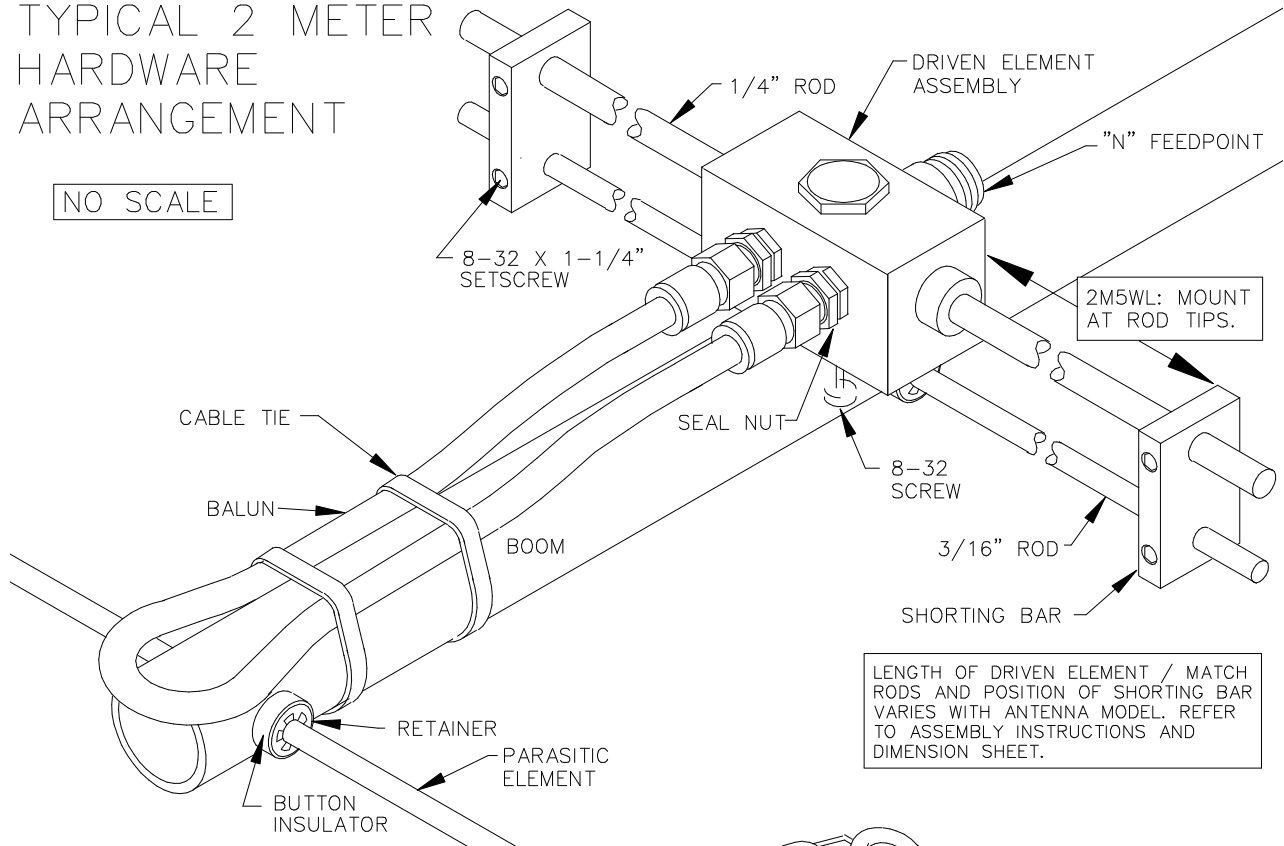

ELEMENT PLACEMENT
VARIES WITH MODEL

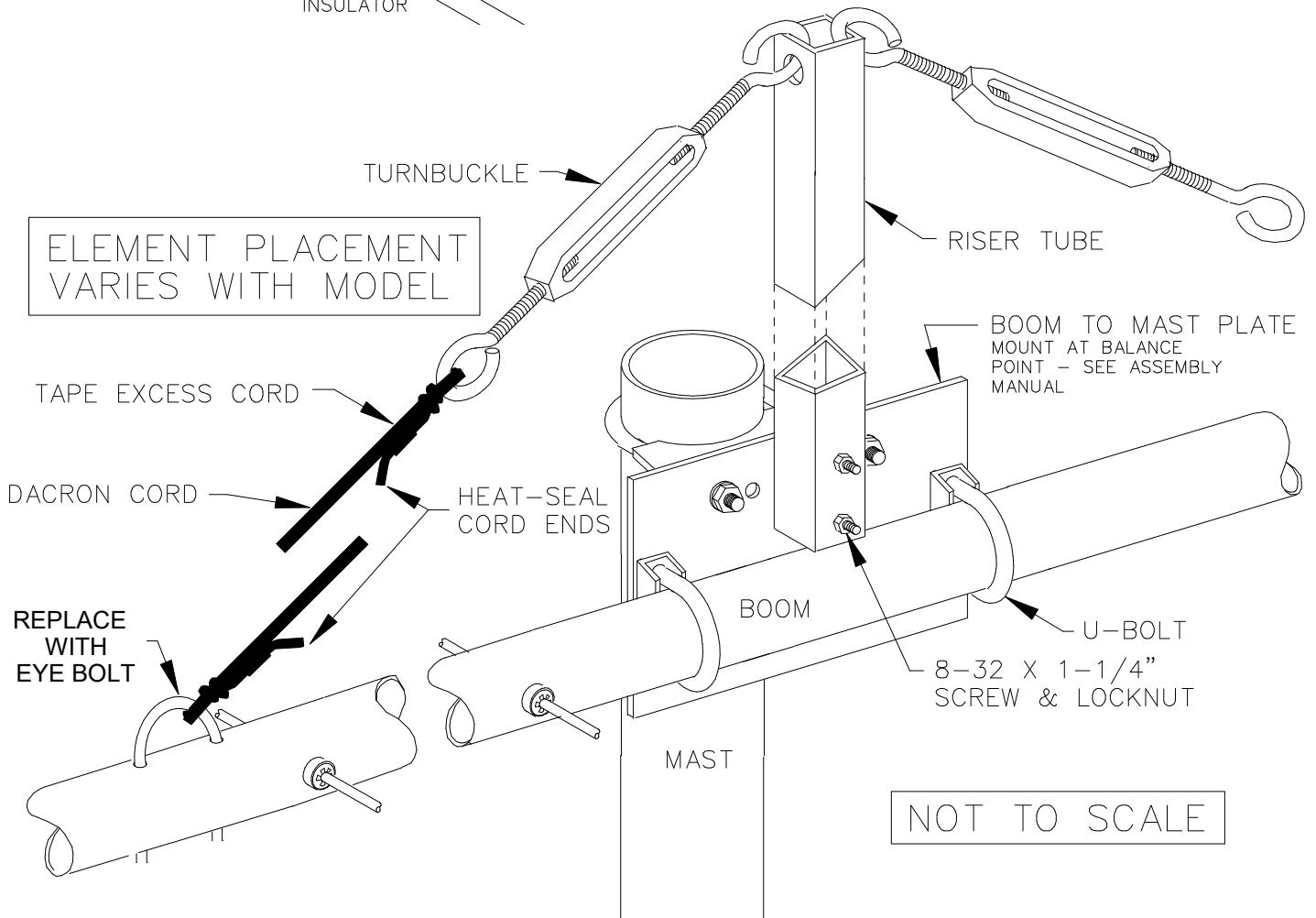

2M5WL PARTS & HARDWARE

DESCRIPTION	QTY
BOOM SECTION #1, 1 X .058 X 60" STR	1
BOOM SECTION #2, 1-1/4 X .058 X 60" SOE.....	1
BOOM SECTION #3, 1-1/2 X .058 X 60" SOE.....	1
BOOM SECTION #4, 1-1/2 X .058 X 60" SBE	1
BOOM SECTION #5, 1-1/4 X .058 X 60" SOE.....	1
BOOM SECTION #6, 1 X .058 X 60" SOE.....	1
BOOM SECTION #7, 3/4 X .049 X 55" STR	1
ELEMENTS, 3/16 ROD x Dimension Sheet.....	17
DRIVEN ELEMENT BLOCK ASSEMBLY	1
BALUN, RG-6 1/2 WAVE	1
BOOM-TO-MAST PLATE, .188 X 6 X 4".....	1
VERTICAL RISER, 3/4 X 18"	1
TURNBUCKLES, 1/4 X 4'	2
U-BOLT AND CRADLE, 2'	2
U-BOLT AND CRADLE, 1-1/2"	2
DACRON CORD, 3/32" X 25'.....	1
ASSEMBLY MANUAL.....	1
 IN HARDWARE BAG:	
SHORTING BAR.....	2
EYE BOLT X 2.5 ZN	2
BUTTON INSULATORS	34
SHAFT RETAINER, SS	34
NUT, 5/16-18 SS.....	8
LOCKWASHER, 5/16 SS.....	8
NUT, 1/4-20 SS.....	2
LOCK WASER, 1/4 SS	2
SETSCREW, 8-32 X 1/4, SS	4
SCREW, 8-32 X 1-1/4 SS	7
SCREW, 8-32 X 1-1/2 SS	4
SCREW, 8-32 X 1-3/4 SS	4
SCREW, 8-32 X 2 SS	2
LOCKNUT, 8-32 SS.....	16
CABLE TIE, NYLON	5
ALLEN HEAD WRENCH, 5/64"	1
PUSH TUBE, 3/8 X 3"	1

CAREFULLY MANUFACTURED BY:
M2 Antenna Systems, Inc.
4402 N. Selland Ave.
FRESNO, CA 93722
(559) 432-8873 FAX (559) 432-3059