

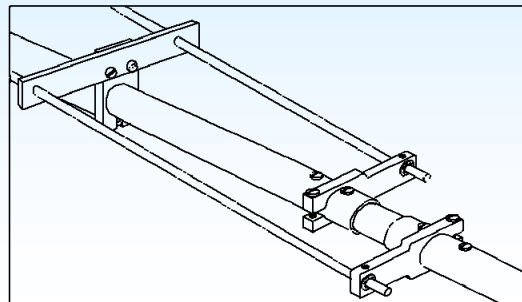

M2 Antenna Systems, Inc.

Model No: 40M1L

HALF ELEMENT DETAIL

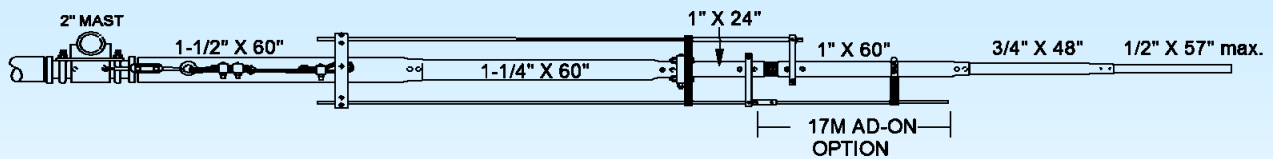

LINEAR LOADING HARDWARE ARRANGEMENT

SPECIFICATIONS:

Model	40M1L	Power Handling	3 kW Higher avl.
Frequency Range tune able	6.9-7.3 MHz X 200 kHz	Boom Length / Dia	N/A
*Gain, (FS) / Over gnd.....	1.75 dBi / 7.2 dBi @ 70'	Element Length / Dia.	46' / 1 1/2" to 1/2"
Front to side.....	15-20 dB Height depend	Turning Radius:	23'
Beamwidth	E = 84° H = N/A	Stacking Distance	85' Max
Feed type.....	Direct Feed	Mast Size	2" to 3" Nom.
Feed Impedance.....	50 Ohms Unbalanced	Wind area / Survival	3 Sq. Ft. / 100 MPH
Maximum VSWR	2.0:1	Weight / Ship Wt.	22 Lbs. / 25 Lbs.
Input Connector	SO-239 Others avl.		

***Subtract 2.14 from dBi for dBd / FS = Free Space**

FEATURES:

This simple antenna combines 15 years of design and field experience with CNC machined parts to become the worlds best rotatable, reduced size dipole. Everything we have learned about linear loaded dipoles and structural reliability has been designed into the 40M1L. We just stretched it a bit and broad banded it to cover at least 250 kHz or more. We also have added an option to make it a dipole on 17 meters as well. The center insulator is a solid 1-1/4 inch fiberglass rod. There is nothing here to weaken or break from the effects of sun, wind or ice loading.

The linear loading elements have been lifted slightly above the main element to eliminate the tension/compression problems of other designs. The linear loading also lifts the whole element slightly virtually eliminating droop. Newly designed shorting bars make assembly and adjustment easier and quicker. If desired, optimizing inside the 40 meter band is done with 1/2" tip adjustment. A Husky 1:1 balun delivers all your transmit power to the antenna with no feed line radiation or pickup.

40M1L ASSEMBLY MANUAL

A small container of zinc paste (Penetrox, Noalox, or equivalent) has been provided to enhance and maintain the quality of all electrical junctions on this antenna. Apply a thin coat wherever two pieces of aluminum come in contact or other electrical connections are made.

ELEMENT ASSEMBLY – SEE ELEMENT ASSEMBLY DRAWING

1. Assemble the 1" sections first. Locate the LINEAR LOADING ARMS and the 7/8 x 9" long fiberglass rod insulator. It may be necessary to spread the opening of the arms lightly with a round screwdriver shank or equivalent in order to slide them into position between the two mounting holes in each section. Connect the two sections to the fiberglass with 8-32 x 1-1/2" screws and locknuts. Note that the arms closest to the fiberglass insulator should be pushed right up against the inner screws and can be used to hold the locknut while tightening the screw. Secure the arms with 8-32 x 1-1/2" screws and locknuts.

2. Now assemble the flat black stabilizer insulators to the support arms using 8-32 x 1" screws and locknuts. Slide these assemblies about 4" onto the end of the short 1" tube sections. Don't tighten yet.

3. Next attach the 3/4" x 48" tubes to the swaged ends of the longer 1" sections using 8-32 x 1-1/4" screws and locknuts.

4. Now assemble the 1-1/2 x 60" section to the 1-1/4" x 60" sections using 8-32 x 1-3/4" screws and locknuts. Tighten securely. Then, if it is not already inside the 1-1/2" sections, insert a 1-3/8 x 24" section into each element butt.

5. Next, locate the large 1-1/4 x 24" fiberglass rod and slip a white Polyethylene ring on each end to about 1-1/2" inside the two holes in the rod. Now slide the rod carefully into the sleeved 1-1/2" element butt, align the holes and install a 1/4-20 x 2-1/4" bolt, lock washer and nut at this time. Tighten securely and repeat for the other 1-1/2" element butt. These bolts form studs where the BALUN leads will attach later.

6. Now return to the 1" sections with the linear loading arms. Install an 8-32 x 1/4" set screw into each arm. Next slide a 3/16" x 57" rod through the black stabilizer insulator and on into the hole in the linear loading arm. Allow the rod to protrude about 1/2" beyond the arm and tighten the set screw. Repeat for the other arm. Repeat for the other side of the dipole element.

7. Locate the small 1/4 x 1/2 x 1" aluminum coupling blocks and install 8-32 x 1/4" set screws. Slide each block 1/2" onto the inner end of the 3/16" rods and tighten the set screw down onto the rod securely. NOTE: be sure the ALLEN wrench is fully inserted into the set screw socket or damage to the set screw and the ALLEN wrench will occur. Now attach the second 3/16" x 57" rod to the coupling block and tighten the set screw. Repeat for all rods.

8. Using a tape measure, hook it to the inner linear loading arm and measure out 108.5" along the rod. Mark the rod at 108.5 inches. Install 3 of 5 screws and locknuts loosely into a pair of shorting bars. Locate the 44" lengths of HPTG phillistran cable and route one end into the MIDDLE HOLE formed by the two shorting bar halves.

Loop the cable around the STRAIN RELIEF and back through the second NEAR MIDDLE hole and allow about 4" of cable to protrude. Now slide this shorting bar assembly onto a pair of 3/16" rod ends and set the edge of the shorting bar at the mark at 108.5". Orient the shorting bars as shown and begin to tighten the screw nearest the marked rod. When it is secure tighten the screw on the other side of the shorting bar pair. Then tighten the middle screw. These screws will hold

40M1L ASSEMBLY MANUAL

the assembly together and the other two screws and locknuts can be added anytime. String on one cable clip and secure it near the shorting bars. Repeat for the other side of the element. Install the shaft retainers on the 3/16" rod ends beyond the arms using the 3/8 x 3" push tube.

9. Using the two 1-1/2" U-bolts, attach the mast mounting plate to the center 1-1/4" rod insulator. Center the plate and align it vertically. Then tighten the nuts.

10. Attach the two turnbuckles to the 'L' shaped turnbuckle angle plate and extend the turnbuckles evenly until just one thread is exposed inside the body of the turnbuckle.

11. Using one 2" U-bolt, TEMPORARILY attach the turnbuckle plate to the mast mounting plate in the top set of holes. Now, install a cable eye (thimble) in the eye of the turnbuckle. Slide two cable clips onto the HPTG 1200 Philistran attached to the shorting bar assembly and string the cable through the turnbuckle eye, around the thimble and back through the two of cable clips. Tighten the cable and then secure its position with the two cable clips. Repeat for the other side. Remove the 2" U-bolt from the mast plate but leave it attached to the turnbuckle angle plate. This part is now ready to be mast mounted.

12. The 1:1 BALUN can be attached to the two 1/4-20 x 2" bolts near the butt of each element half or it can be attached later at the time of installation on the mast. The BALUN normally mounts below the dipole and is attached to the mast with the two large nylon ties supplied.

13. Attach the 3/4 x 48" element sections to the 1" sections at this time, using 8-32 x 1-1/4" screws and locknuts. Tighten securely.

14. Now is the time to determine what frequency you want to optimize the dipole. Consult the chart below. A nominal setting of 45" exposed 1/2" tip sections will yield a 2:1 or better match across most of the 40 meter band with the best match occurring at approximately 7.150 MHz. This setting was tested at 50 feet above ground. Mounting the dipole lower or very near to other antennas or antenna booms may move the best match lower in frequency. Mounting the dipole in the clear at heights above 50 feet will raise the frequency slightly and can affect the match.

This tuning chart is a guide. Surrounding objects and height above ground will cause shift in frequency. Your results may vary. For operation outside the frequency range shown here, please consult with M2 Engineering.

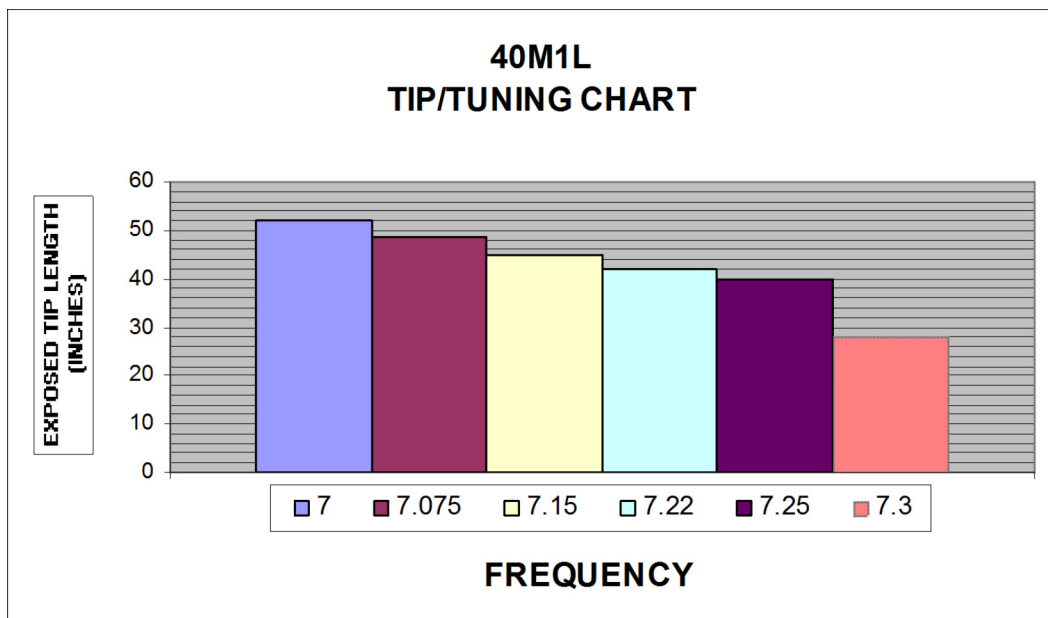

40M1L ASSEMBLY MANUAL

Depending upon the final height of the dipole, the feed impedance can range from about 30 Ohms up to about 75 Ohms. This is normal and will not affect the performance of the antenna.

15. Note the 1/2" tip section has not been drilled. Note also that it is 60" long. You can insert the tip into the desired EXPOSED LENGTH. We recommend inserting to the desired EXPOSED LENGTH. Use a compression clamp to hold the tip at the desired length. (see compression clamp / tip assembly detail)

IF POSSIBLE , WE RECOMMEND TESTING THE FREQUENCY RESPONSE OF THE DIPOLE AT THIS TIME AT A HEIGHT AT OR NEAR THE FINAL LOCATION. If this is not possible, then drill the second set of holes, attach the hardware and tighten securely.

16. Once the Dipole is completed, re-check each element half for tight hardware and tight SET SCREWS.

17. The dipole is now ready to be mounted on your 2" mast. 2" U-bolts and stainless steel 5/16" lockwashers / nuts are supplied for mast mounting; THIS COMPLETES THE ASSEMBLY.

18. When mounting on your mast, the dipole is normally attached first, and aligned with or at 90 degrees to other antennas on the mast. Then the turnbuckle angle plate is attached and raised above the dipole enough to lift the elements slightly until the inner two element sections are not bowed down. However this is not critical unless you expect heavy ice loading. For this condition it will help to raise the turnbuckle angle plate until the elements are tilted up slightly. Final small adjustments of the element can be done with the turnbuckles. Be sure to safety wire the turnbuckles once the final setting is achieved. Good luck and SEE YOU ON 40! De K6MYC.

THIS COMPLETS ANTENNA ASSEMBLY

M² ANTENNA SYSTEMS, INC.

4402 N. SELLAND AVE.

FRESNO, CA 93722

(559) 432-8873 FAX (559) 432-3059

www.m2inc.com Email: sales@m2inc.com

40M1L ASSEMBLY DETAILS

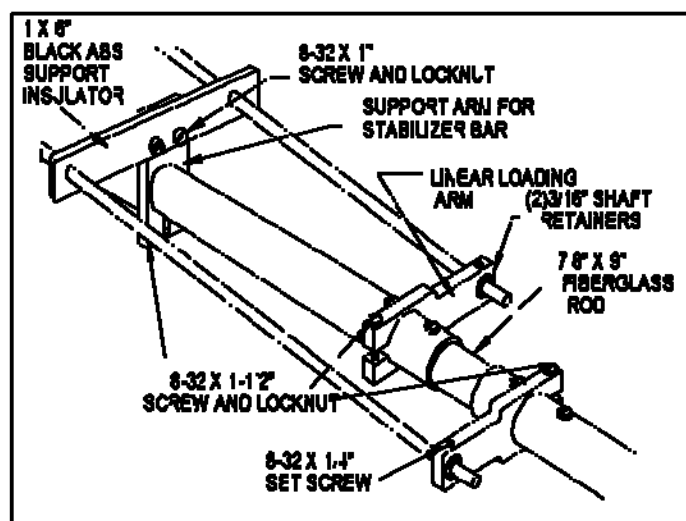
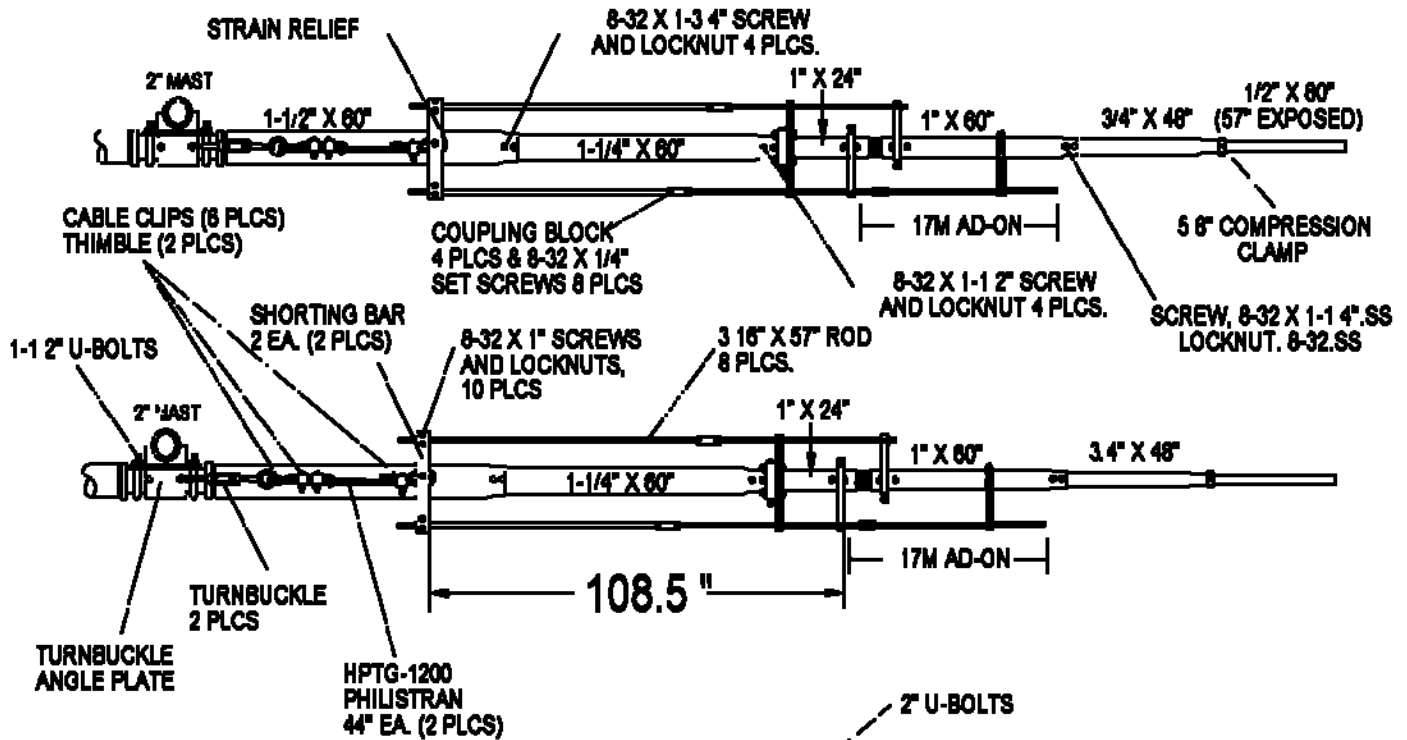

HALF ELEMENT W/17 METER ADD-ON KIT

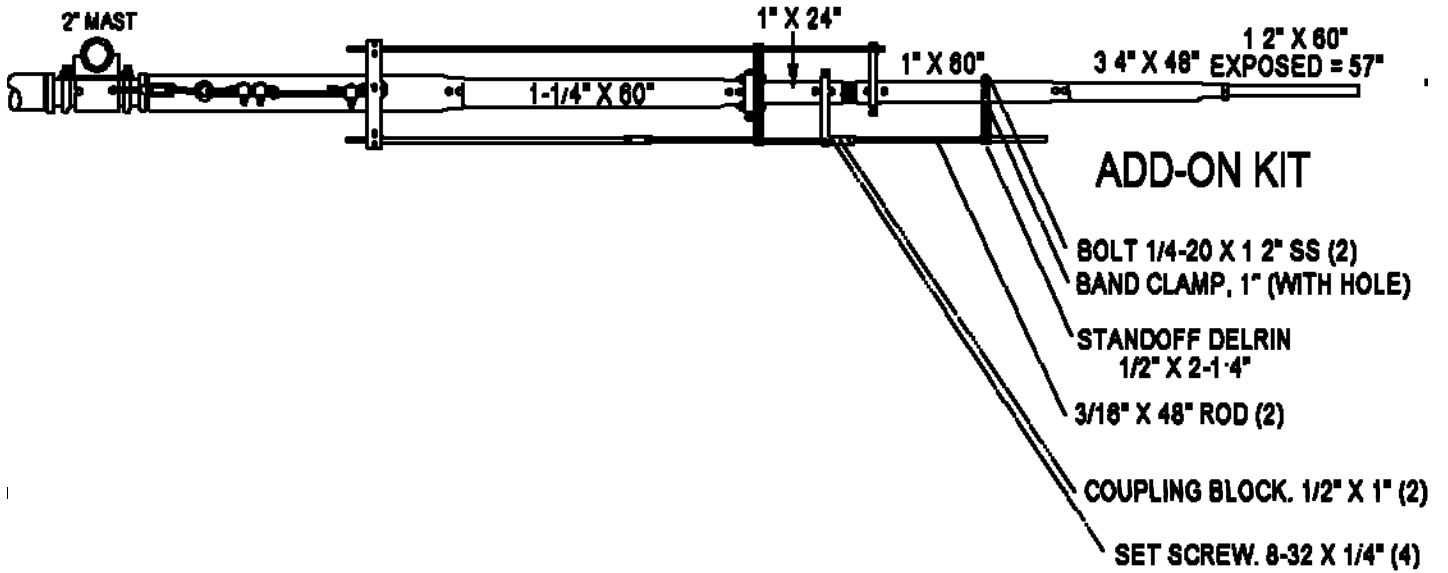

GENERIC COMPRESSION CLAMP DETAIL

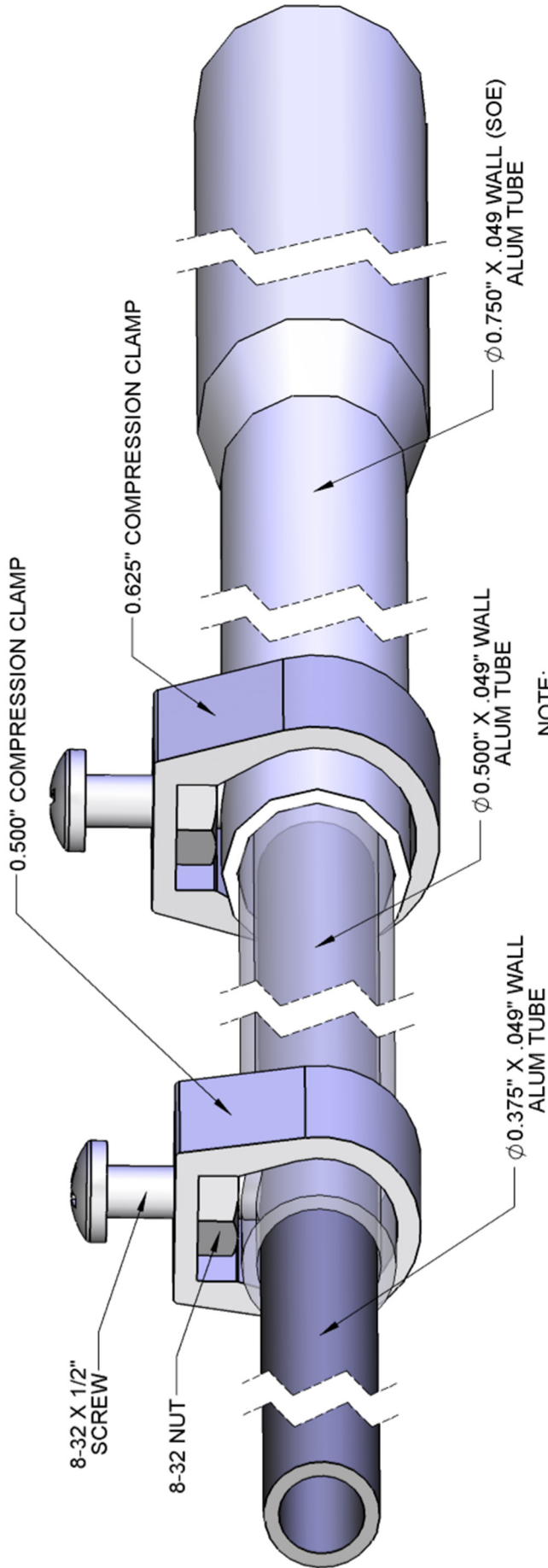

NOTE:
TUBES SHOWN TRANSPARENT
TO SHOW MORE DETAIL

NOTE:

Generic layout to show how compression clamps work. Your antenna may have one or the other or may even have both compression clamp sizes.

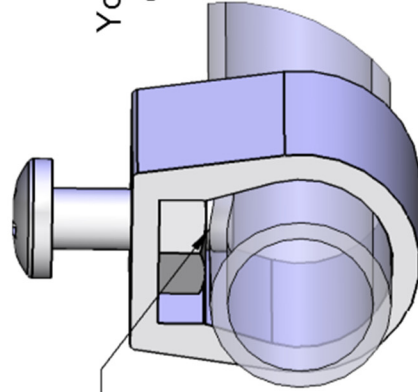

NOTE: INSIDE TUBE NOT SHOWN FOR CLARITY

40M1L PARTS & HARDWARE

DESCRIPTION	QTY
ELEMENT, 1-1/2 X .058 X 60 SOE	2
SLEEVE, 1-3/8 X .058 X 23 13/16"	2
ELEMENT, 1-1/4 X .058 X 60 SOE	2
ELEMENT, 1 X .058 X 24"	2
ELEMENT, 1 X .058 X 60 SOE	2
ELEMENT, 3/4 X .049 X 48" SOE	2
ELEMENT, 1/2" X .049 X 60"	2
LINEAR ELEMENT, 3/16 X 57" ALUM ROD	8
INSULATOR, CENTER, 1-1/4 X 24" FIBERGLASS ROD	1
INSULATOR, LINEAR 7/8 X 9" FIBERGLASS ROD	2
SUPPORT ARM, FOR SUPPORT INSULATOR (M2APL0201)	2
SUPPORT INSULATOR, LINEAR LOADING STABILIZER (M2APL0200)	2
BALUN, 1:1, SO-239 CONNECTOR (FGBL0100)	1
MAST PLATE 6 X 6" X 3/16" ALUM (M2APT0300)	1
ANGLE PLATE, FOR TURNBUCKLES. 2 X 2 X 4" (M2APT0120)	1
PHILLISTRAN HTPG-1200 X 44"	2
ASSEMBLY MANUAL	1

HARDWARE BOX

DISC INSULATOR, 3/8 X 2" POLY., 1-1/4" HOLE	2
TURNBUCKLE, 1/4- X 4"	2
LINEAR LOADING ARM 3/8 X 1-1/4 X 2-3/4" ALUM. (M2APL0255)	4
SHORTING BAR HALF, 1/4 X 3/4 X 5-7/8" ALUM (M2ASB0250)	4
PHASE STRAIN RELIEF 1/2" X 1/2" BLACK DELRIN	2
5/8" COMPRESSION CLAMP	2
U-BOLT AND SADDLE, 2"	3
U-BOLT AND SADDLE, 1-1/2"	2
U-BOLT AND SADDLE, 2-1/2"	1
ZINC PASTE	1

IN HARDWARE BAG

NUT 5/16-18 SS	12
LOCKWASHER, 5/16" SPLIT RING SS	12
BOLT, 1/4-20 X 2-1/4" SS	2
LOCKNUT, 1/4-20, LOCKING, SS	2
NUT, 1/4-20	2
LOCKWASHER, 1/4 SPLIT RING	2
SCREW, 8-32 X 1-3/4" PAN SS	4
SCREW, 8-32 X 1-1/2" PAN SS	18
SCREW, 8-32 X 1-1/4" PAN SS	4
SCREW, 8-32 X 1" PAN SS	14
SCREW, 8-32 X 1/2" PAN SS	2
SET SCREW 8-32 X 1/4" INT HEX SS	12
NUT, 8-32 LOCKING SS	40
NUT 8-32 SS	2
LINEAR COUPLING BAR, 1/4 X 1/2 X 1" ALUM.	4
SHAFT RETAINERS, 3/16" SS	4
CLIP, 3/16"	6
CABLE EYE, 3/16"	2
ALLEN WRENCH, 5/64	1
PUSH TUBE, 3/8 X 3", FOR RETAINER INSTALL	1

M² ANTENNA SYSTEMS, INC.
 4402 N. SELLAND AVE.
 FRESNO, CA 93722
 (559) 432-8873 FAX (559) 432-3059
 www.m2inc.com Email: sales@m2inc.com

(17M KIT) OPTIONAL PARTS & HARDWARE

DESCRIPTION	QTY
ROD ELEMENT, 3/16" X 48" ALUM.....	2

HARDWARE:

COUPLING BLOCK 1/2 X 1" ALUM.....	2
STANDOFF, DELRIN 1/2 X 2-1/4" TAPPED FOR 1/4-20.....	2
HOSE CLAMP, #12, MODIFIED WITH 1/4" HOLE	2
BOLT, 1/4-20 X 1/2", SS	2
SET SCREW, 8-32 X 1/4", SS	4
ASSEMBLY INSTRUCTIONS.....	1

M² ANTENNA SYSTEMS, INC.
4402 N. SELLAND AVE.
FRESNO, CA 93722
(559) 432-8873 FAX (559) 432-3059
www.m2inc.com Email: sales@m2inc.com