

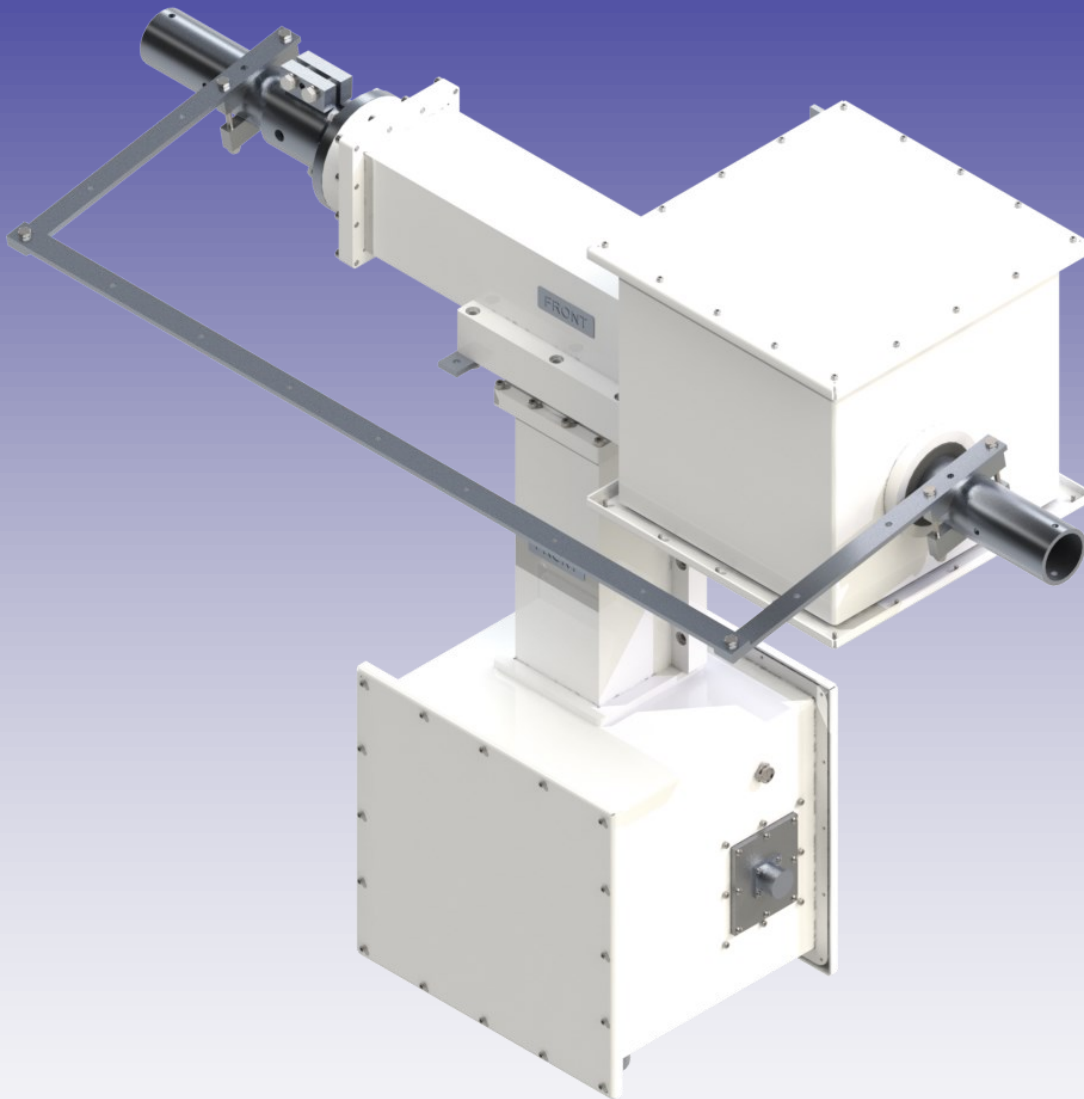

M2 Antenna Systems, Inc.

Model No: FGAE1000-D1-W-C-A-H



SPECIFICATIONS:

Model FGAE1000-D1-W-C-A-H
Motor Type DC Motor
Worm Gear Configuration Single
Enclosure Type Weatherproof

Mount Style.....Cross Boom
Body Material.....Aluminum
Environment Control.....Heater

3" PIPE CLAMPS (OPTIONAL)

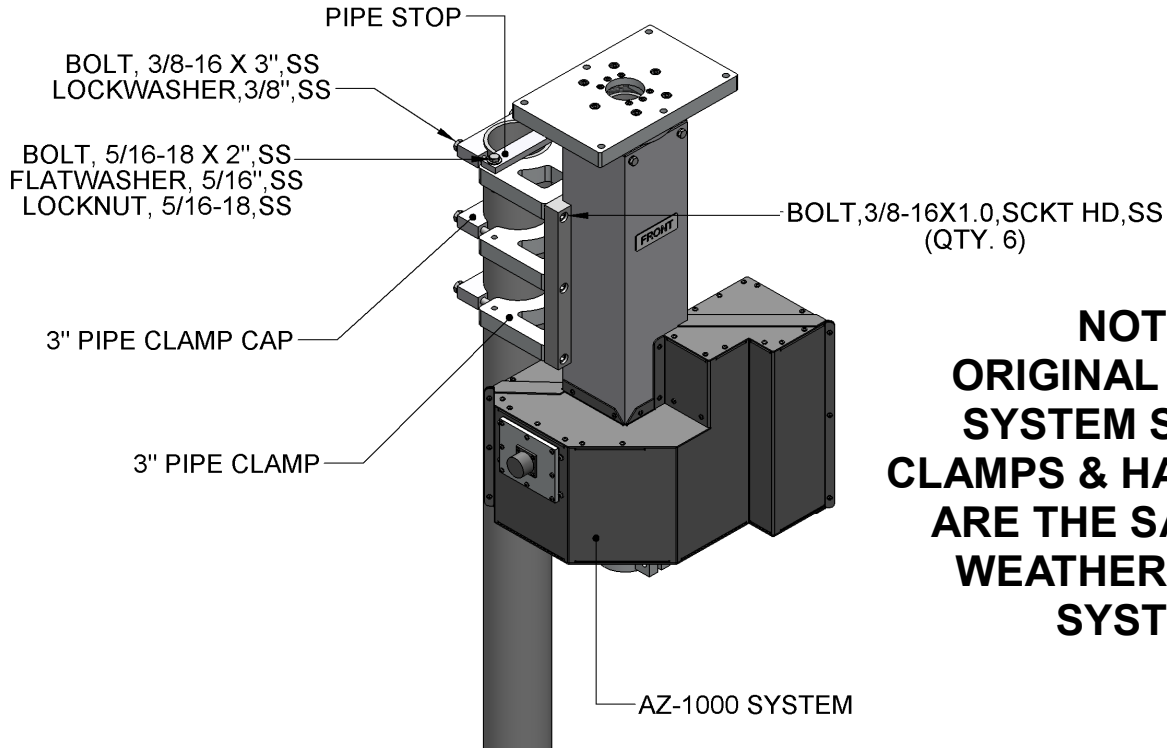

**NOTE:
ORIGINAL AZ-1000
SYSTEM SHOWN.
CLAMPS & HARDWARES
ARE THE SAME FOR
WEATHER PROOF
SYSTEM**

6" PIPE CLAMPS (OPTIONAL)

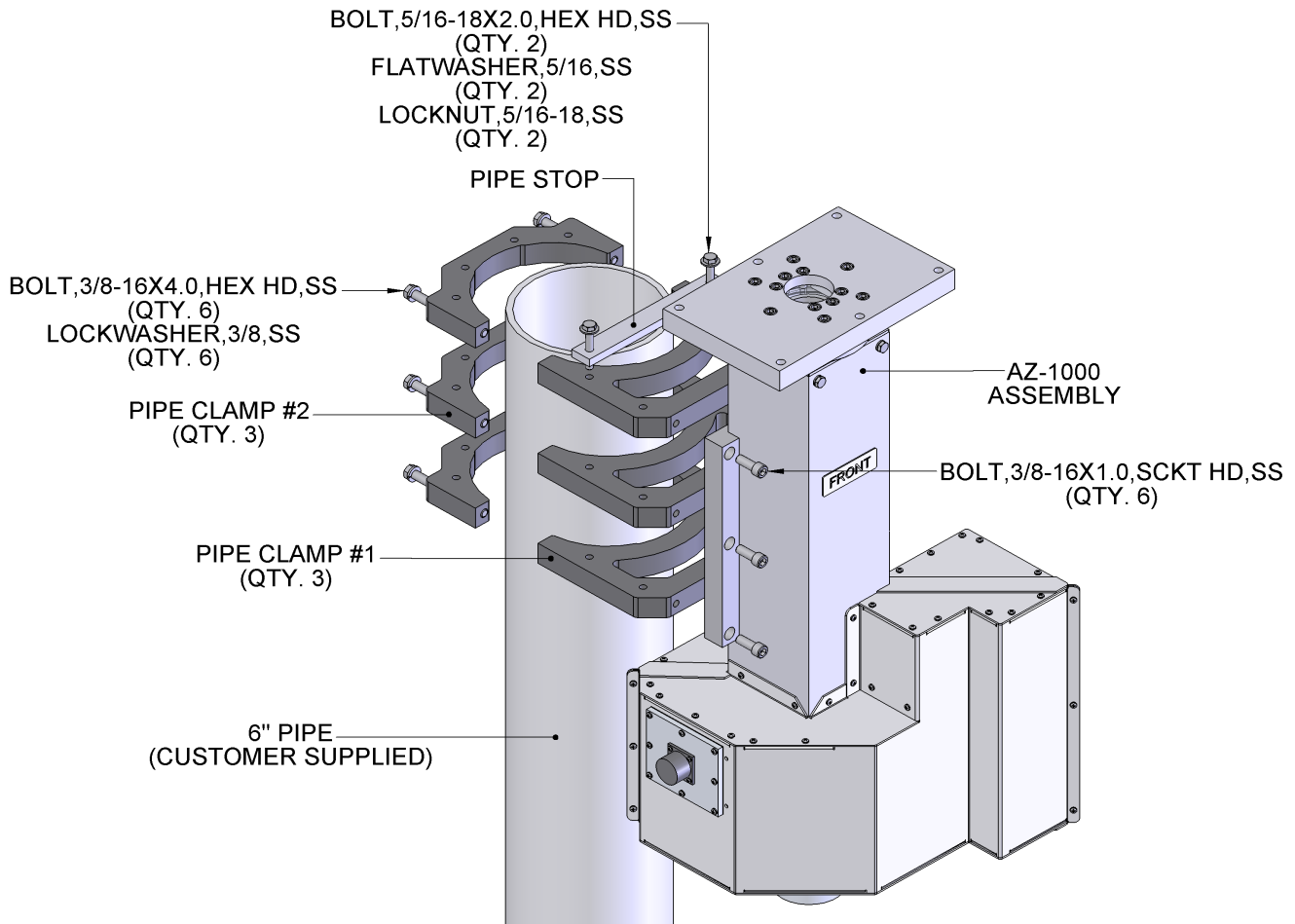

FGAE1000-D1-W-C-A-H ASSEMBLY

NOTE:
INSTALL O-RING BEFORE
ATTACHING EL-1000CBW
THE USE OF SILICON
GREASE IS RECOMENDED

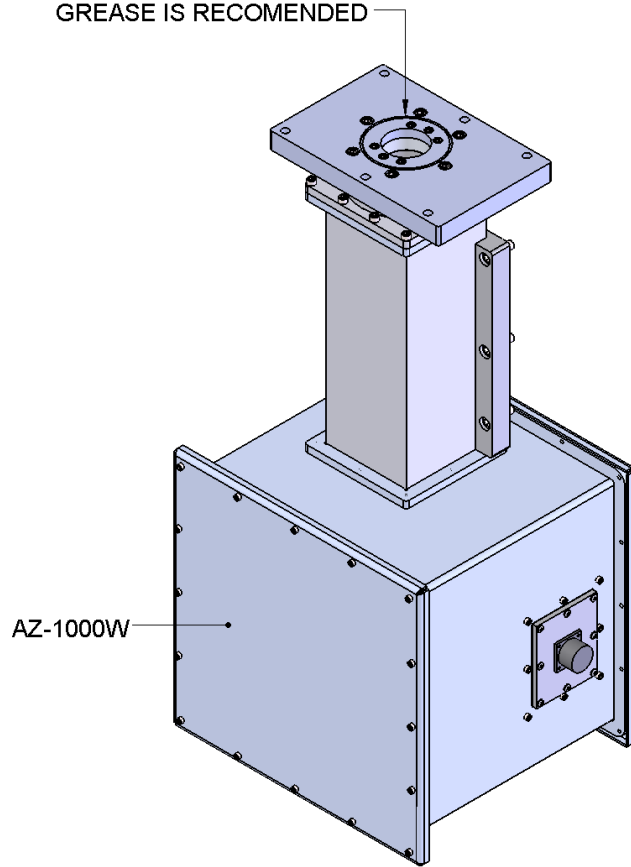

BOLT, 3/8-16 X 1",SS
(QTY. 6)

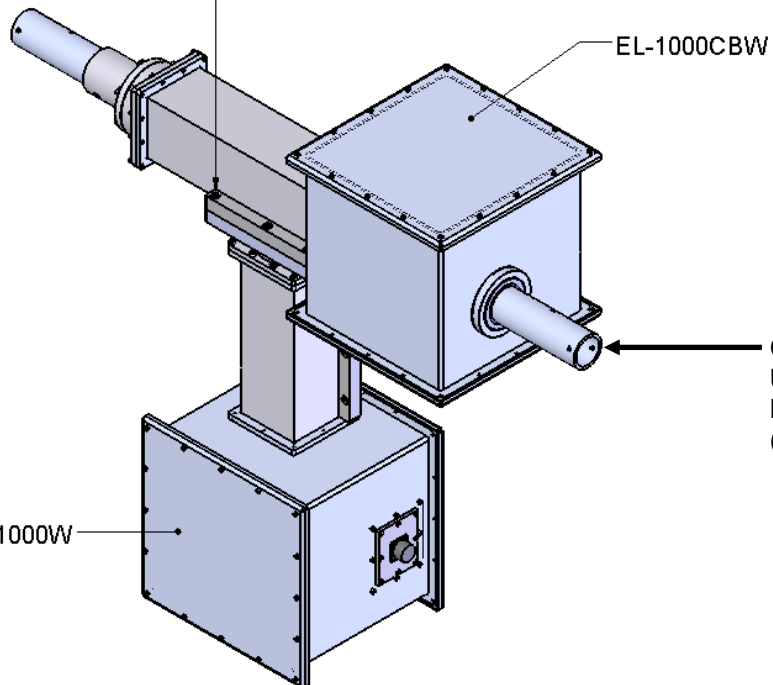

FGAE1000-D1-W-C-A-H ASSEMBLY

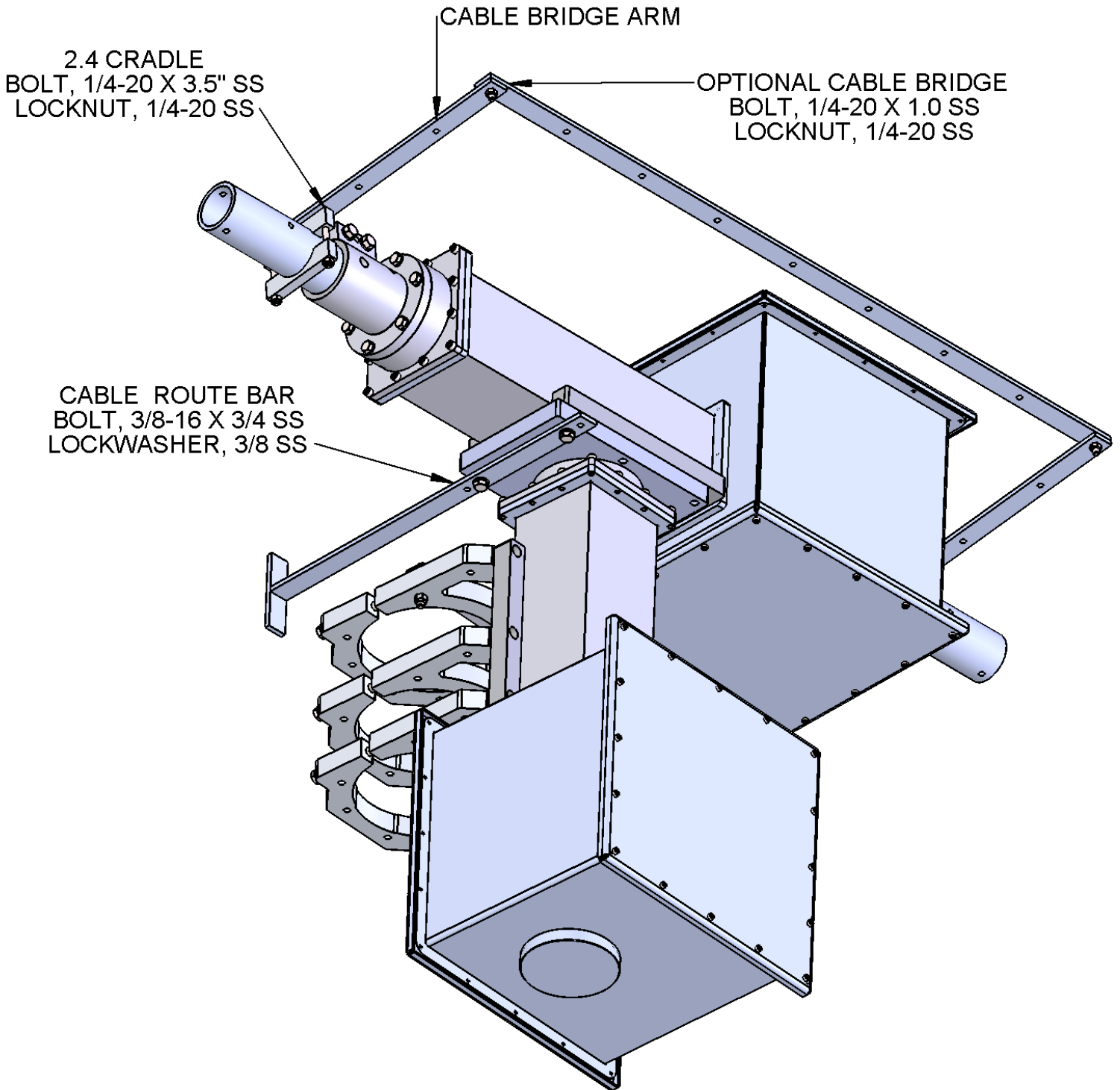

FGAE1000-D1-W-C-A-H ASSEMBLY

NOTE: When using 180 degrees over the top elevation movement during tracking, the cable bridge can collide with the cable routing bar and associated cables. When mounting the cable bridge, be sure the elevation system is on the horizon, then position the cable bridge 10-30 degrees below the horizon to avoid collision with the cable routing bar. Confirm clearance before any un-manned operations.

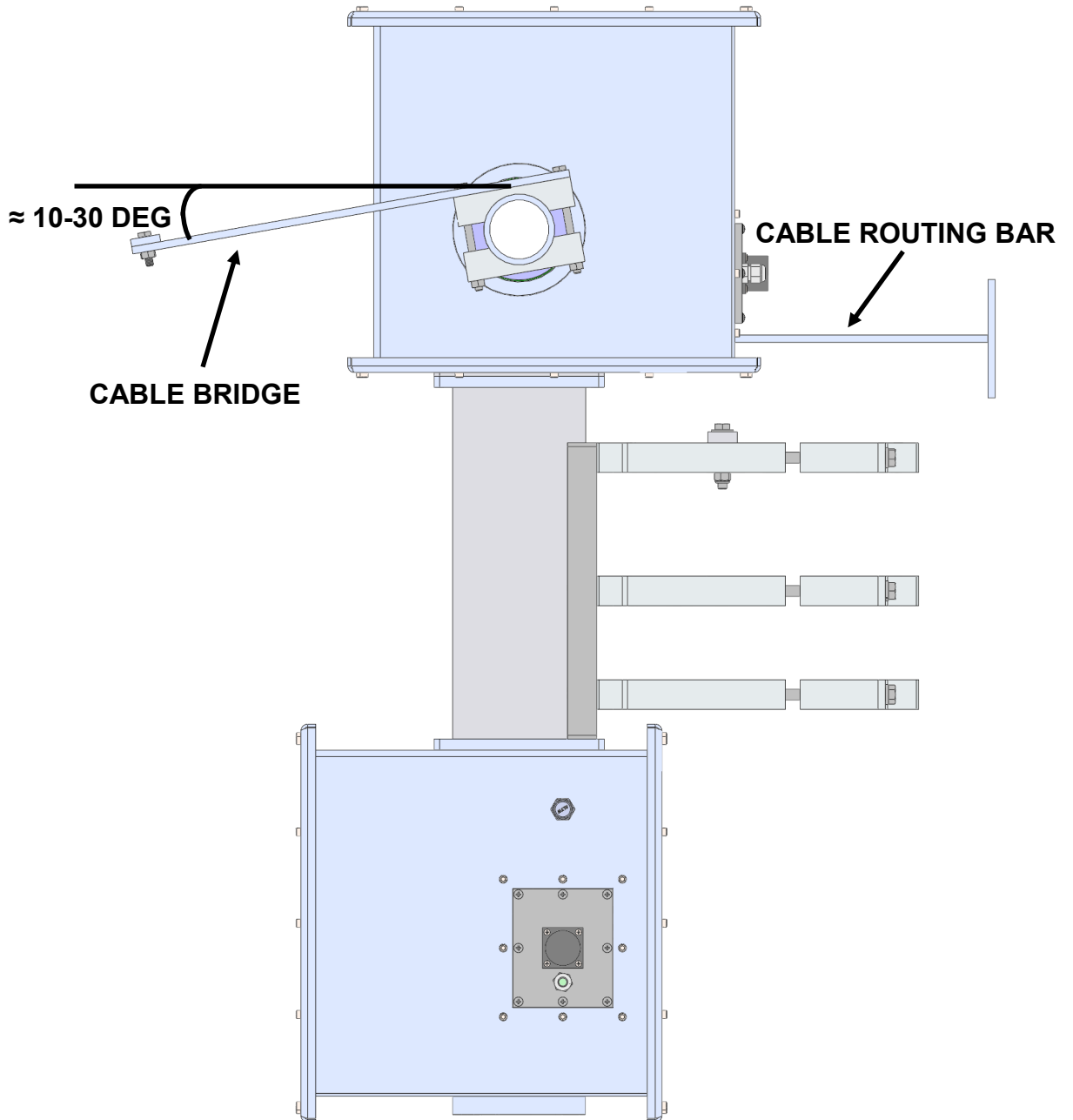

CABLE ROUTE FLAG (CBW)

NOTE:

Elevation cable route shown for Cross Boom Weather System.
See pages 7-9 for more cable route information.

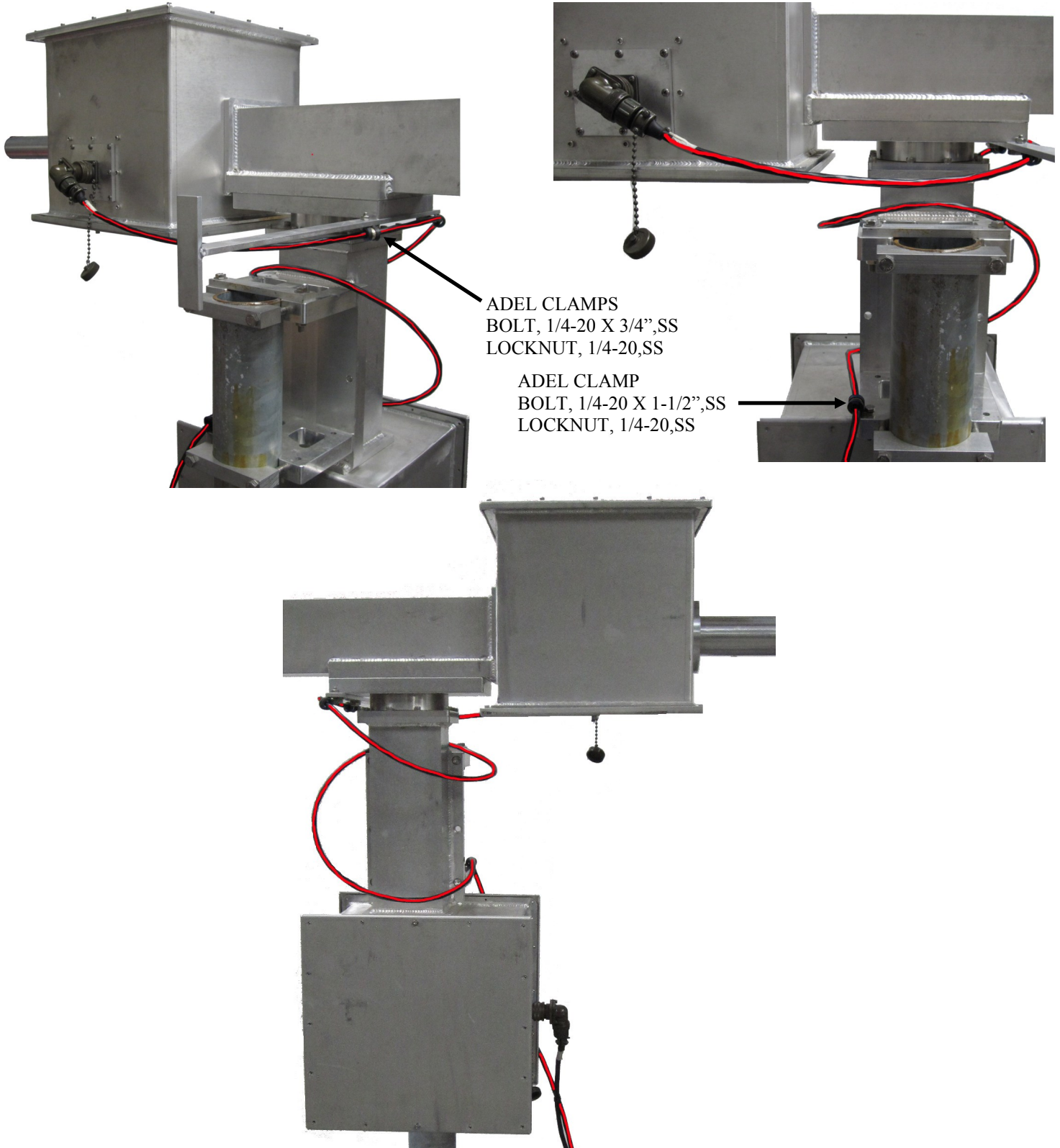

CABLE ROUTE FLAG & BRIDGE

Note: The starting point for all cables that move with AZ or EL rotation. The AZ is at full counter clockwise and EL at 0 degrees.

Figure 1

The RED Elevation control cable comes up to the elevation motor unit. Once this cable is connected to the Cable Route Flag it does not move or change as the unit is moved in Azimuth or Elevation. The RED cable is supported along the Cable Route Flag with two cable clamps.

The BLUE antenna cables are supported along the Cable Route Bridge Bars and secured with cable ties or equivalent. The BLUE cables have a full 360° turn around the elevation unit body. With the antenna elevation at 0° elevation, these cables can be quite tight and close to the elevation body. Cables will open or loosen significantly as the elevation is moved from 0° to 180°.

Figure 2

The RED Elevation control cable has a full 360° loop around the upper AZ support column. This 360° loop will increase in size as the AZ unit rotates in a clockwise direction. Note. Red Cable is supported by a third cable clamp at the bottom of the upper pipe mount clamp.

Figure 3

The BLUE antenna cables are ending the 360° loop at the small T at the end of the Cable Route Flag. Secure as shown with two cable ties or equivalent. The BLUE cables then drop to the pedestal base with RED Elevation & Azimuth rotation control cables.

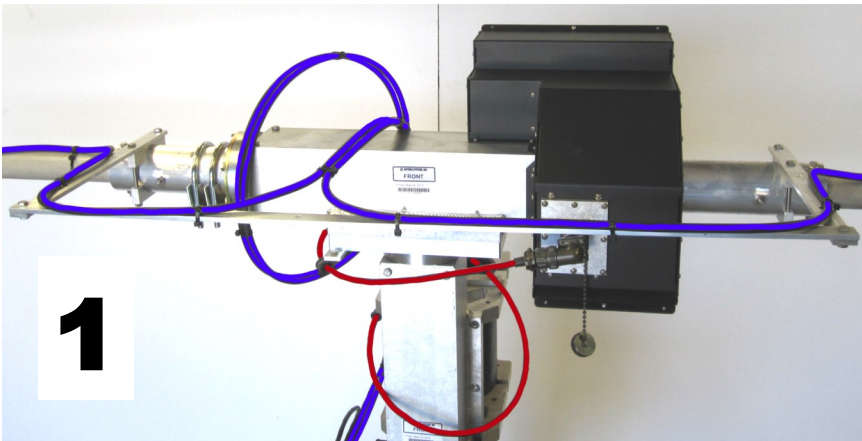

NOTE:
GENERIC POWER DIVIDER
BRIDGE SHOWN FOR
CABLE ROUTE EXAMPLE.

POWER DIVIDER BRIDGE
SETUP MAY BE DIFFERENT.
REFER TO MASTER SYSTEM
MANUAL FOR MORE DETAILS.

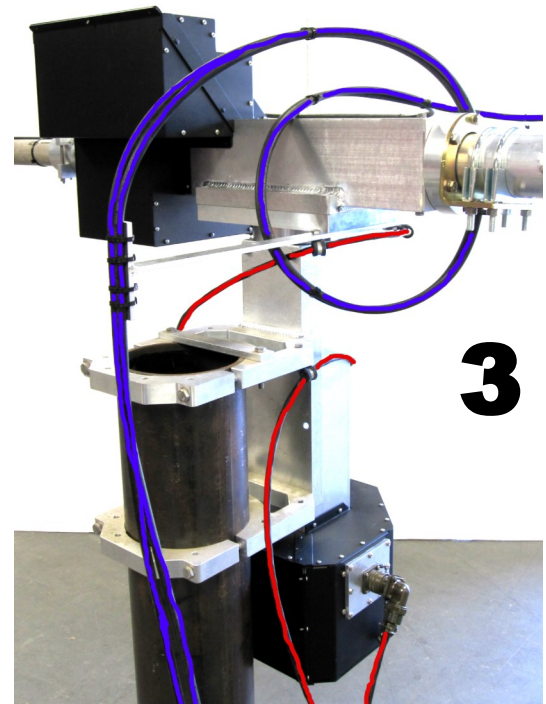
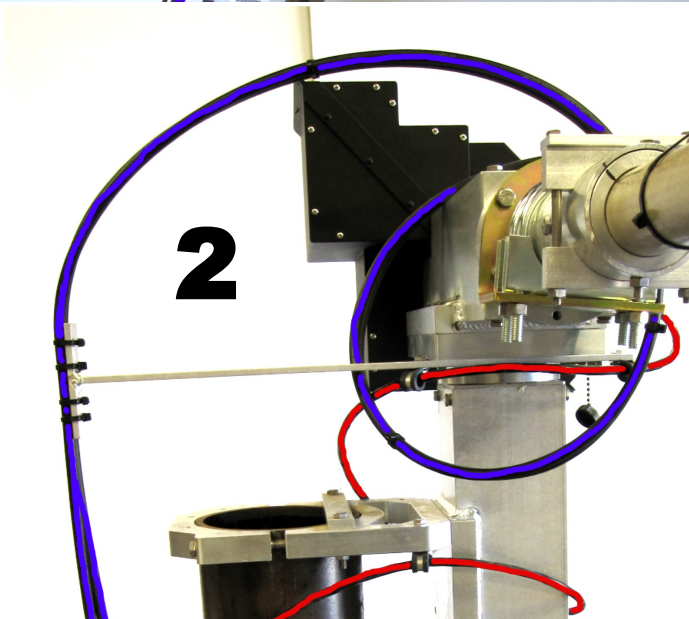

CABLE ROUTE FLAG & BRIDGE

Setting up the AZEL1000 for cable routing.

1. Set the front of the system to the center of the azimuth rotation. (Example: If the system will rotate 0 to 360 degrees set the front of the system at 180 degrees). This way the cables will only need to move 180 degrees from the center of its total movement. The same can be set up for elevation. (Example: If the system will elevate 0 to 90 degrees set the elevation at 45 degrees).
2. Start with the elevation control cable (highlighted in red) it should be routed with a 360 degree loop around the upper azimuth body. This loop will increase and decrease in size as the azimuth rotates to each end of its spectrum. Note the positions of the Adel Clamps in figure 1 and figure 3. Note upper end of the elevation cable can be quite direct to the connector of the elevation unit, as this section of the cable will not move when the system is being articulated. The lower end of the loop attaches with a Adel clamp to the underside of the upper pipe clamp and can drop down and meet up with the azimuth control cable. Note the control cables will not move as the system is articulated.
3. The RF cables (highlighted in blue) are generally coming from the antennas mounted on the supporting structure. These cable are routed from the antennas from each side of the array coming together near the center of the cable support bridge. The cables should make one and a half loop around the inside section of the elevation body, between the cable route "T" bar and elevation motor cover and attaching to the cable route "T" bar with cable ties as shown in figure 3.

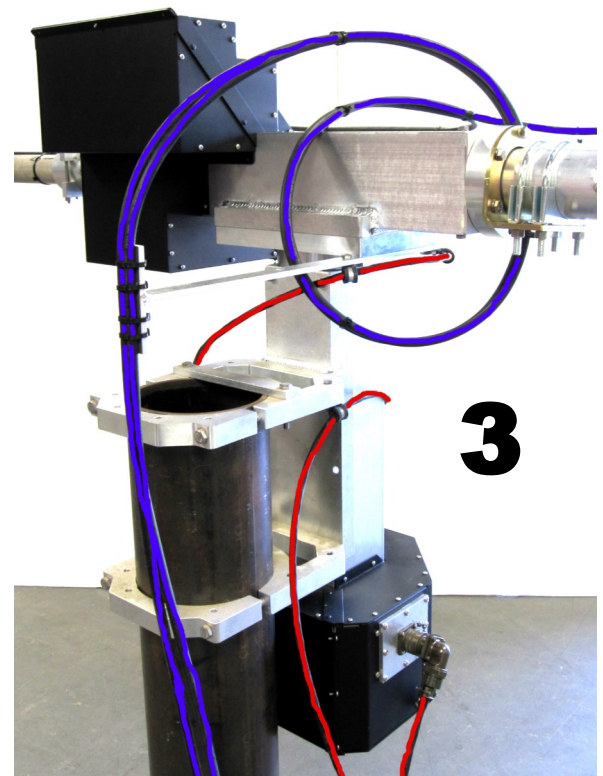
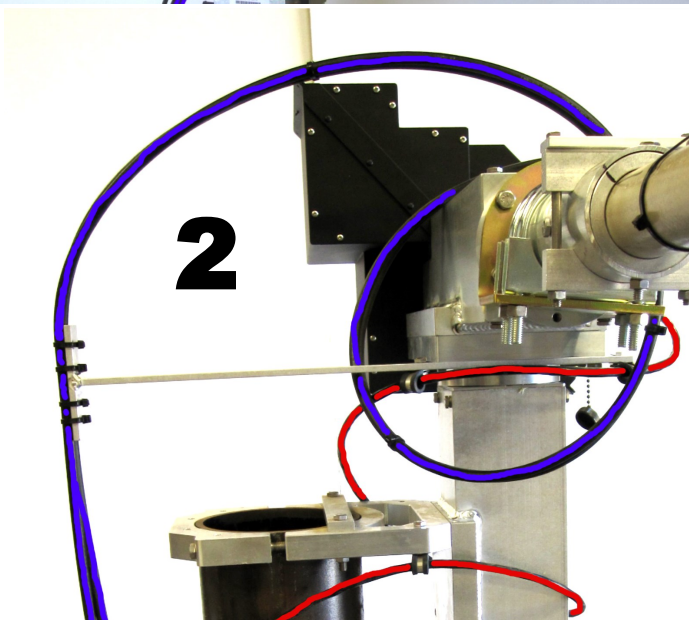
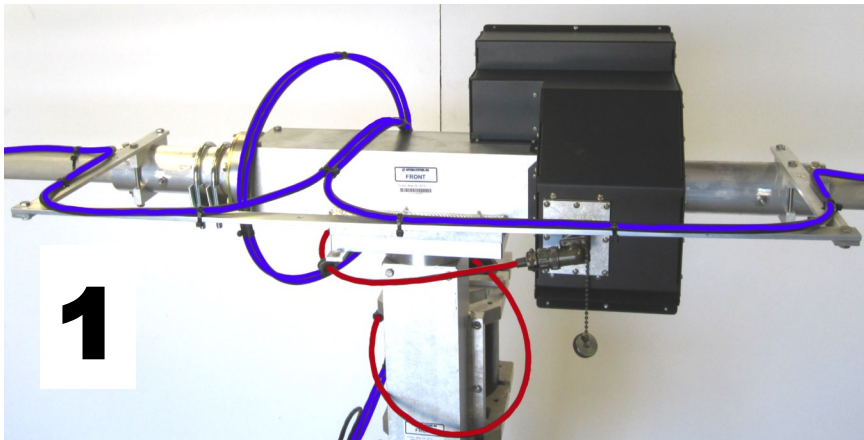

NOTE:
GENERIC POWER DIVIDER
BRIDGE SHOWN FOR
CABLE ROUTE EXAMPLE.

POWER DIVIDER BRIDGE
SETUP MAY BE DIFFERENT.
REFER TO MASTER SYSTEM
MANUAL FOR MORE DETAILS.

CABLE ROUTE FLAG DETAILS

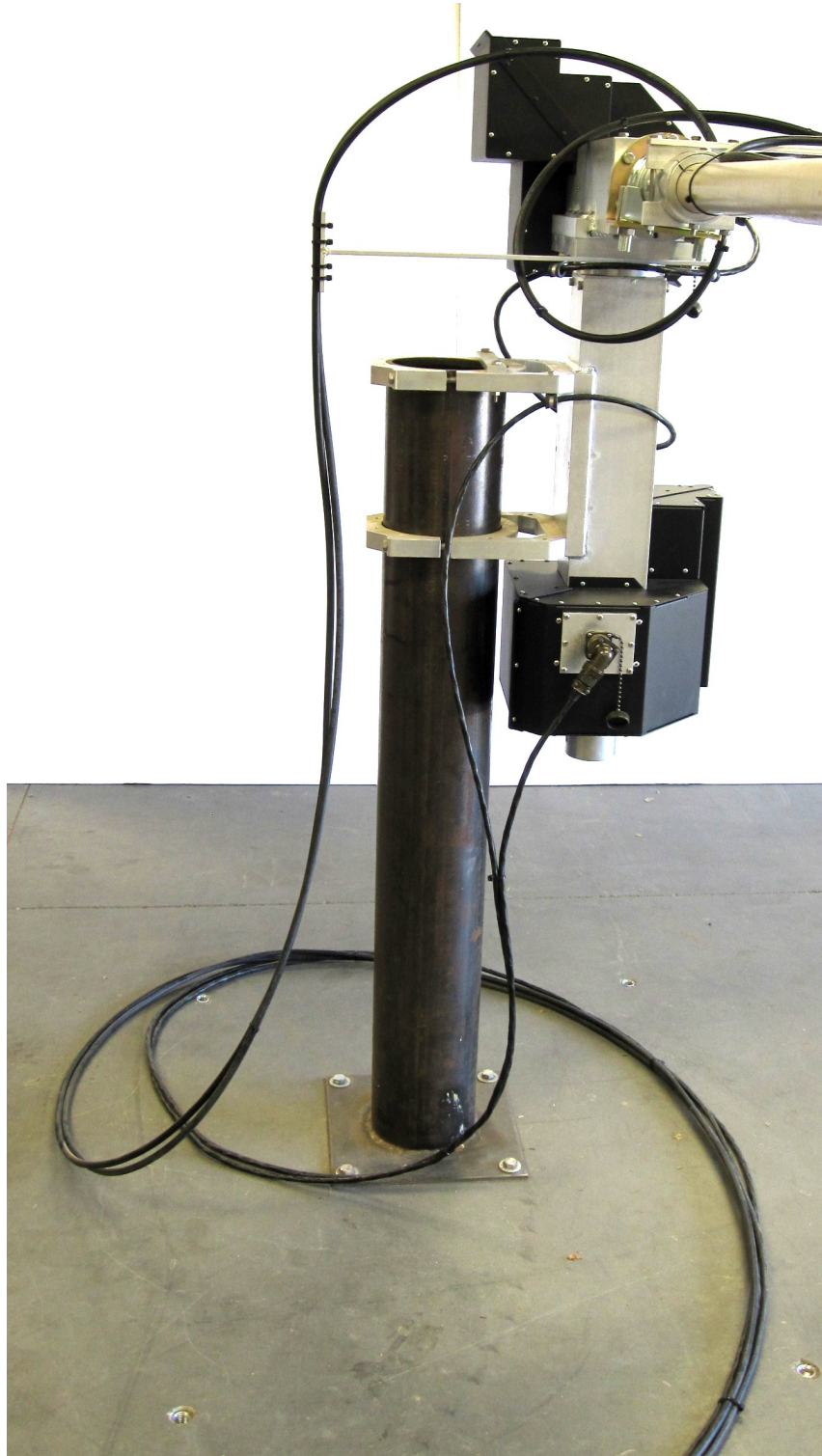

Note: The axis control cables and the RF cables are not tied together as the RF cables will rotate as the system articulates.

This photo shows a significant loop of cables required for 360° azimuth rotation.

Once all the cables are attached, take time to slowly rotate the system through full 180° elevation and 360° azimuth to be sure no cable stress or hang-ups occur.

FGAE1000-D1-W-C-A-H PARTS & HARDWARE

<u>DESCRIPTION</u>	<u>QTY</u>
AE1000 ELEVATION ASSEMBLY (SAAE1948)	1
AE1000 AZIMUTH ASSEMBLY (SAAE1935)	1
7 PIN FEMALE RIGHT ANGLE CONNECTOR ASSEMBLY	2
CABLE ROUTE BAR (WELDED, M2AAE1615).....	1
CABLE BRIDGE ARM (M2AAE1617)	2
CABLE BRIDGE (M2AAE1618)	1
2.4" CRADLE (M2AMC0128)	4
O-RING BUNA #153	1
PENETROX OR ZINC PASTE (1 OZ. CUP).....	1

HARDWARE

BOLT, 3/8-16 X 1.0", SOCKET HEAD, S.S.....	12
BOLT, 3/8-16 X 3/4", HEX HEAD, S.S.....	2
LOCK WASHER, 3/8", S.S.....	2
BOLT, 1/4-20 X 3.5" HEX HEAD S.S.....	4
BOLT, 1/4-20 X 1.0" HEX HEAD S.S.....	2
LOCK NUT, 1/4-20, S.S.....	6
SCREW, 8-32 X 1/2", SET, S.S.....	4
ALLEN KEY, 5/64"	1

OPTIONAL KITS

PIPE MOUNT KIT, 3" (FGAEPMK3)

<u>DESCRIPTION</u>	<u>QTY</u>
3" PIPE CLAMP (M2AMC0144)	3
3" PIPE CLAMP CAP (M2AMC0149).....	3
3" PIPE STOP (M2AAE1608)	1

HARDWARE

BOLT, 3/8-16 X 3", HEX HEAD, S.S.....	6
LOCK WASHER, 3/8", S.S.....	6
BOLT, 5/16-18 X 2", HEX HEAD, S.S.....	2
FLAT WASHER, 5/16", S.S.....	2
LOCK NUT, 5/16-18, S.S.....	2

PIPE MOUNT KIT, 6" (FGAEPMK6)

<u>DESCRIPTION</u>	<u>QTY</u>
6" Pipe Clamp #1 (M2AMC0143)	3
6" Pipe Clamp #2 (M2AMC0142)	3
6" Pipe Stop (M2AAE1606).....	1

HARDWARE

Bolt, 3/8-16 x 4", Hex Head S.S.....	6
Lock Washer, 3/8" S.S.....	6
Bolt, 5/16-18 x 2", Hex Head S.S.....	2
Flat Washer, 5/16", S.S.....	2
Lock Nut, 5/16-18, S.S.....	2

AZ/EL JUNCTION BLOCK CONNECTIONS

The pictures on this page shows the standard wiring in the junction boxes (with switch reversing diodes) & 7 pin female right angle connector assembly. The system works the following way: Current is constant through the limit switches and through to the positioner. When the limit switch is activated, it breaks the contact and stops the current from continuing. Reversing the positioner in the opposite direction, incorporates directional diodes. Because this is a standard wiring system, there may be variations to this system that may be changed by your specific orientation of each Axis.

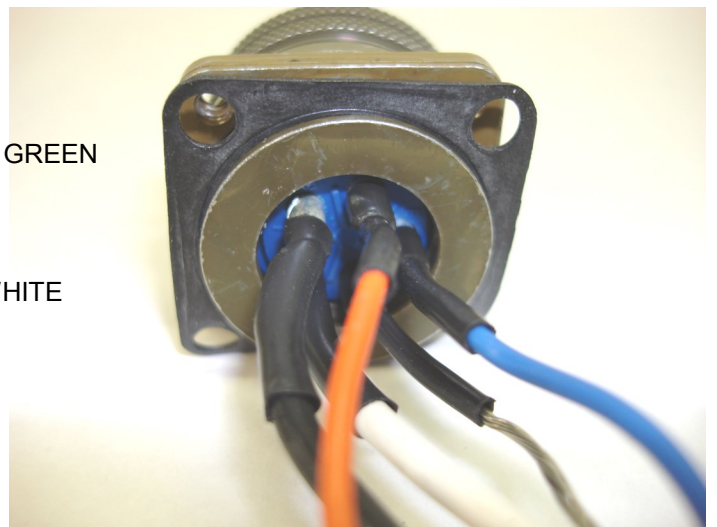
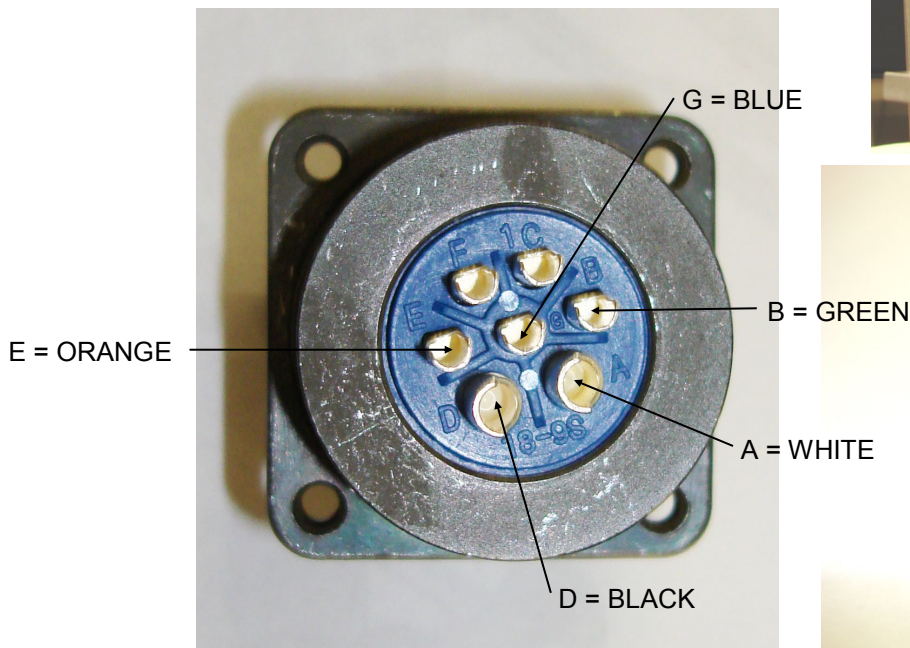
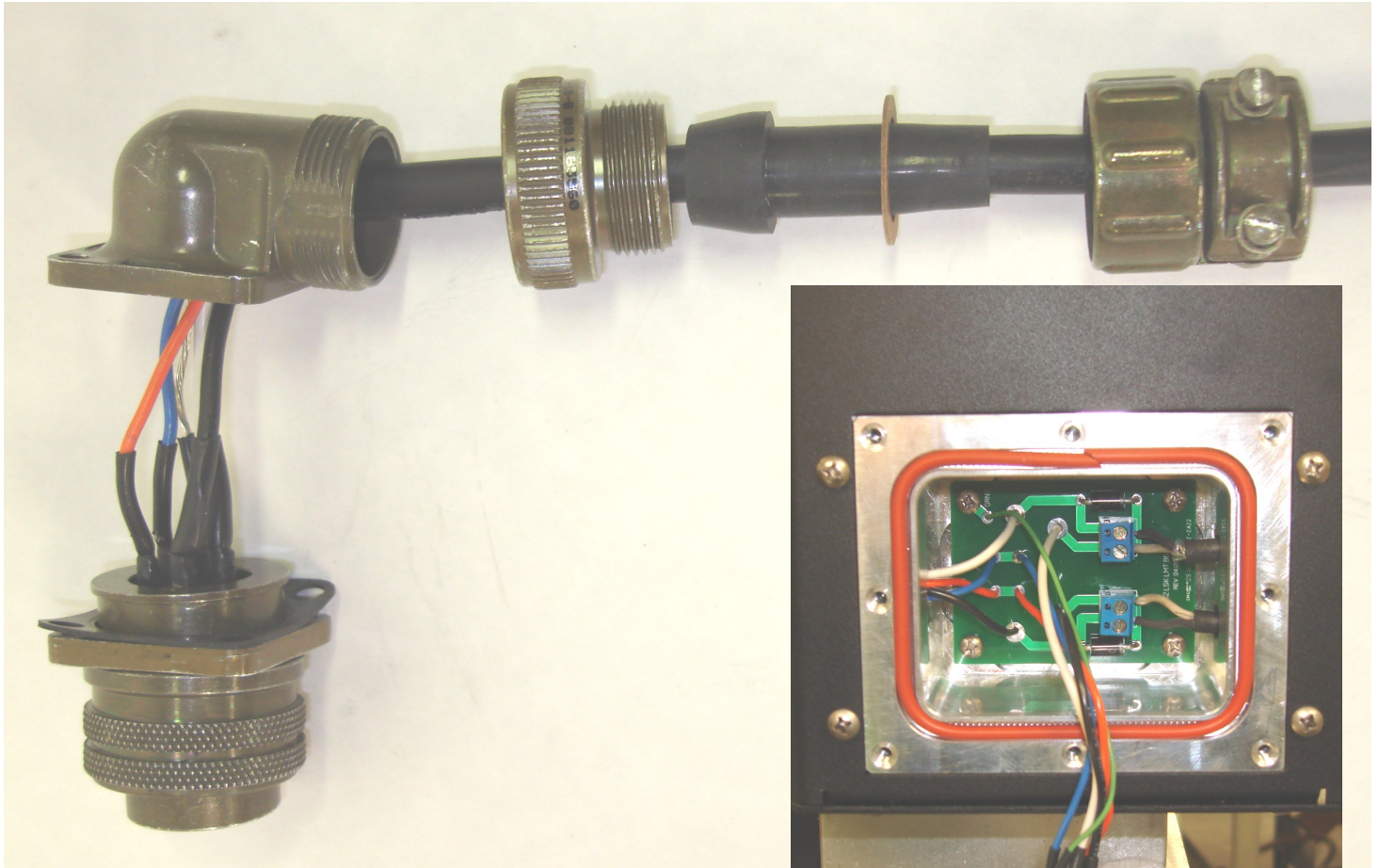

AZ/EL PHYSICAL LIMIT SWITCH TEST

LSK-1000 OVERVIEW:

The **LSK-1000** limit switch kit is a physical hard backup limit. The standard control unit supplied with our AZ or EL has “**Electronic Limits**”, but the **LSK-1000** limit switch kit, has been designed as a physical backup system in the event of a control unit failure. The factory has pre-installed the **LSK-1000** limit switch kit into the AZ and EL units for you. Typically the **LSK-1000** limit switches only need to be setup once, but can be adjusted when necessary.

LSK-1000 MANUAL LIMIT SWITCH PRE-TEST:

Remove one half of the black enclosure from the positioner unit that **DOES NOT** have cord grips or wires running into it. You will see the limit switches (**A,B**) the limit arm (**C**), and limit screw (**D**) as pictured to the right. **We have not installed the limit screw due to unknown customer orientation.** Move the supplied **RC2800** control unit near the positioner for proper limit switch testing. With the positioner wired to the control unit, turn the control unit on. Be sure to test the proper direction of each positioner before moving forward. Once you have determined the correct direction of rotation from the control units’ “Control Buttons,” determine which limit switch will be activated by the rotation of the main gear and limit screw. Press a known direction using the “Control Buttons,” and manually activate the limit switch. At this point the positioner should stop it’s travel. Continue holding the limit switch and reverse the direction using the “Control Buttons.” The motor should move away from the engaged limit switch. This confirms proper wiring and operation of the limit switch. Repeat this procedure for the other direction and limit switch. We suggest, completing each axis (ie Azimuth and Elevation) prior to moving onto the final setup.

AZ/ EL-1000 LIMIT SWITCH ARRANGEMENT

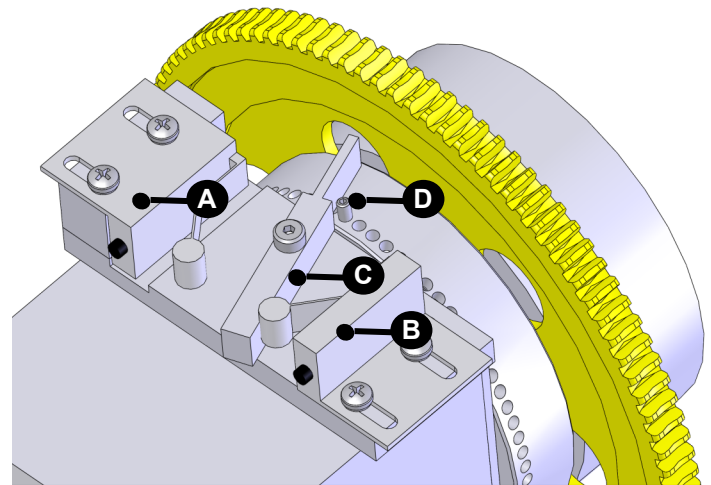

FINAL SETUP OF THE LIMIT SET SCREWS:

We have included (2) limit screws, one for each limit switch. The limit screws can be setup at any position based upon the orientation of your choice. On Azimuth and Elevation use the supplied 8-32 x 1/2” set screws and 5/64 allen wrench. **DO NOT INSTALL AT THIS TIME.** You can always make slight adjustments to the limit screw if necessary. We have provided adjustment holes at every 5°. We suggest leaving the cover off of the unit until you have completed your testing.

MAINTENANCE INFORMATION

90 day maintenance

1. Visual inspection of complete system, look for rust or corrosion and loose hardware.
2. Manually move each axis individually and LISTEN for smooth operation.
3. Check cables for wear and cracking.
4. Check each axis for physical looseness and or backlash (adjust if necessary).
5. Remove covers, check and clean any excessive foreign debris.
6. Grease main gear and worm gear.
7. Check for proper operation of each axis.
8. Replace covers. The use of silicone grease on the O-ring seals is recommended

1 year maintenance

1. Visual inspection of complete system, look for rust or corrosion and loose hardware.
2. Manually move each axis individually and LISTEN for smooth operation.
3. Check cables for wear and cracking.
4. Check each axis for physical looseness and or backlash (adjust if necessary).
5. Remove covers, check and clean any excessive foreign debris.
6. Check AZ-1000 and EL-1000, thrust block oil-light bearings for wear.
7. Check main load bearings for each individual axis and look for radial slop and or bearing binding.
8. Grease main gear and worm gear.
9. Check physical limit switch operation.
10. Check for proper operation of each axis.
11. Replace covers. The use of silicone grease on the O-ring seals is recommended

TROUBLESHOOTING

Troubleshooting

1. Motors not moving.

- A. Check for voltage coming out of control box.
- B. Check for voltage at motor (**AZ / EL=42 VDC**).
- C. Check all wiring from control box to motor.
- D. Check motor for binding.

2. No pulse from motors.

- A. Check all wiring from reed switch to control box.
- B. Replace reed switch.

3. Gear binding.

- A. Check Gears for Grease.
- B. Check gear bolts for looseness.
- C. Check gears for foreign debris.
- D. Adjust thrust block adjustment.

4. Excess backlash

- A. Inspect worm and worm gear for wear.
- B. Inspect for thrust block bearing wear.
- C. Inspect system for loose hardware.
- D. Adjust thrust block adjustment.

5. Excess 3" bearing movement

- A. Inspect bearing for radial movement.
- B. Replace 3" bearing assembly.

6. 3" Bearing Binding

- A. Disassemble bearing assembly and inspect for lubrication and foreign debris. Reassemble and test. Replace if necessary.

For more complete maintenance and technical assistance, please contact M2 Antenna Systems, Inc. at **(559) 432-8873**.

WORM & WORMGEAR ADJUSTMENT

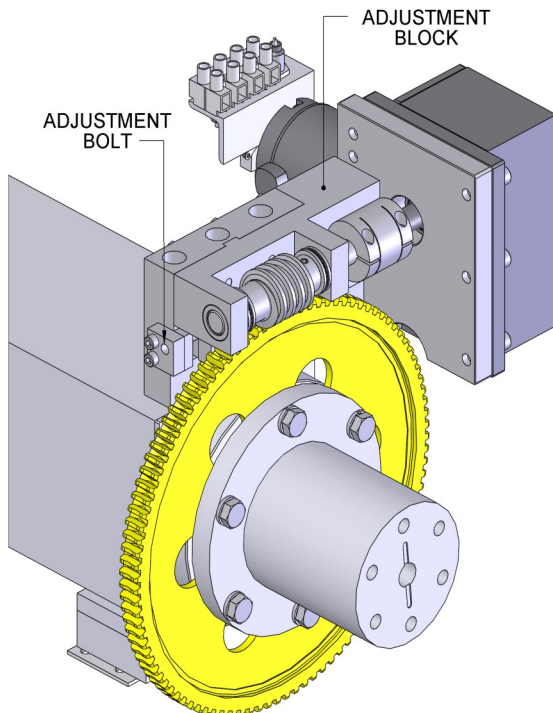
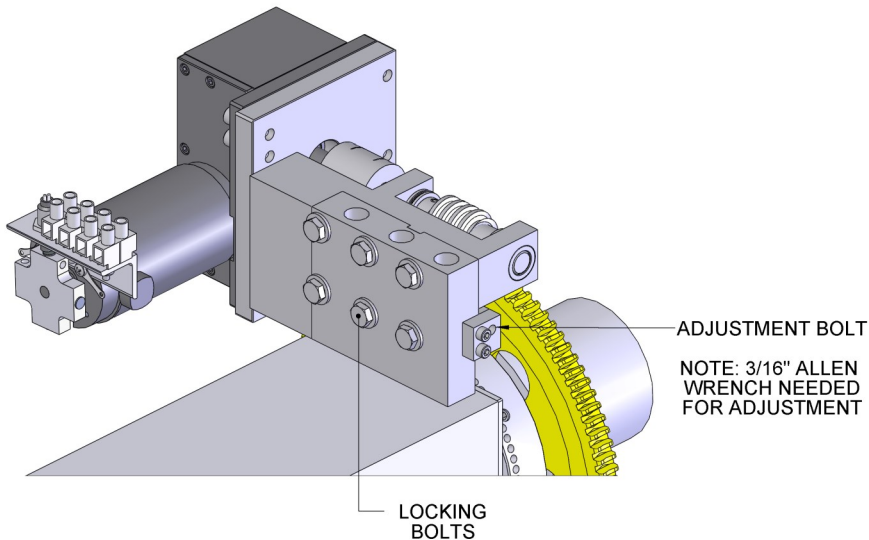

NOTE:
SOME PARTS ARE NOT SHOWN FOR CLARITY

Excessive backlash may develop after using system for some time. We have incorporated a built in backlash adjustment block to keep backlash at a minimum.

Please review drawings shown for more detailed information.

To adjust system:

1. Slightly loosen locking bolts to hand tight.
2. Use a 3/16" Allen wrench to turn adjustment bolt.
3. One full turn of the adjustment bolt will move adjustment block 0.010 of an inch.
4. Clockwise rotation of the adjustment bolt will move the adjustment block down, moving the worm closer to the worm gear and removing backlash.
5. Counter clockwise rotation of the adjustment bolt will move the adjustment block up, moving the worm away from the worm gear and creating more backlash.
6. Adjustments should be made with the motor running. Use the motor drive sound as gauge for friction between worm and worm gear.

Note: Too much friction may cause gear binding in rarely used sections of the worm gear. Some finesse may be required.

7. Tighten locking bolts and test system. Listen for motor running sound for smooth system operation and minimal backlash.

12 Month Limited Warranty Information

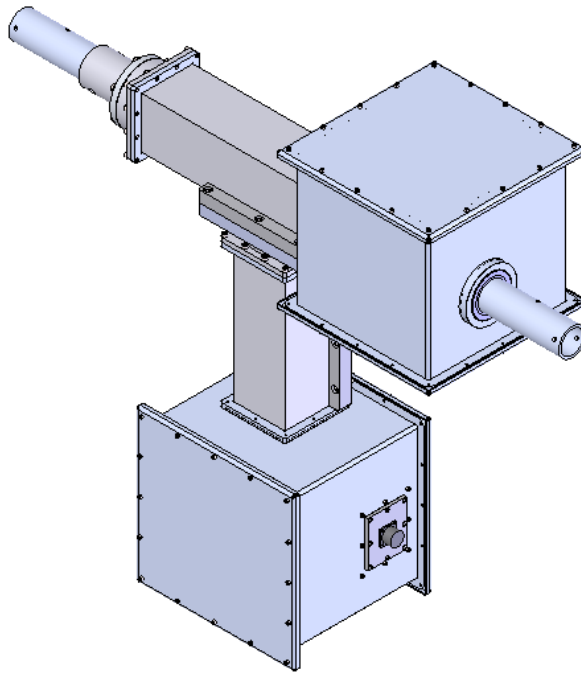

This warranty gives you specific legal rights. You may also have other rights which will vary from state to state or province to province.

M2 warrants the **2-Axis** Positioner unit against defects in material and workmanship for a **period of 12 months** from date of purchase. During the warranty period, **M2** will, at its option, either repair or replace products or components which prove to be defective. The warranty shall not apply to defects or damage resulting from:

- Improper or inadequate maintenance by user
- Improperly prepared installation site
- Unauthorized modifications or misuse
- Accident, abuse, or misapplication
- Normal wear

M2 specifically does not warrant this product for any direct, indirect, consequential, or incidental damages arising from the use or inability to use the product. Some states or provinces do not allow the exclusion or limitation of liability for consequential or incidental damages so the above limitation may not apply.

In the event repair or replacement are necessary, purchaser shall contact **M2** for return authorization. In many cases this contact can simplify and expedite the repair / replacement process and help reduce costs and downtime.

The purchaser shall be responsible for packing the product properly for return and for charges to ship the product to **M2**. Always include with the shipment, a statement detailing the problem / failure and any other pertinent observations. Insuring the product for shipment is recommended. Use the original packing materials whenever possible. **M2** is responsible for charges (**in the United States**) to return the repaired / replacement product only where warranty service is involved.

M2 Antenna Systems, Inc. 4402 N. Selland Ave. Fresno, CA 93722
(559) 432-8873 Fax (559) 432-3059 Web: www.m2inc.com