

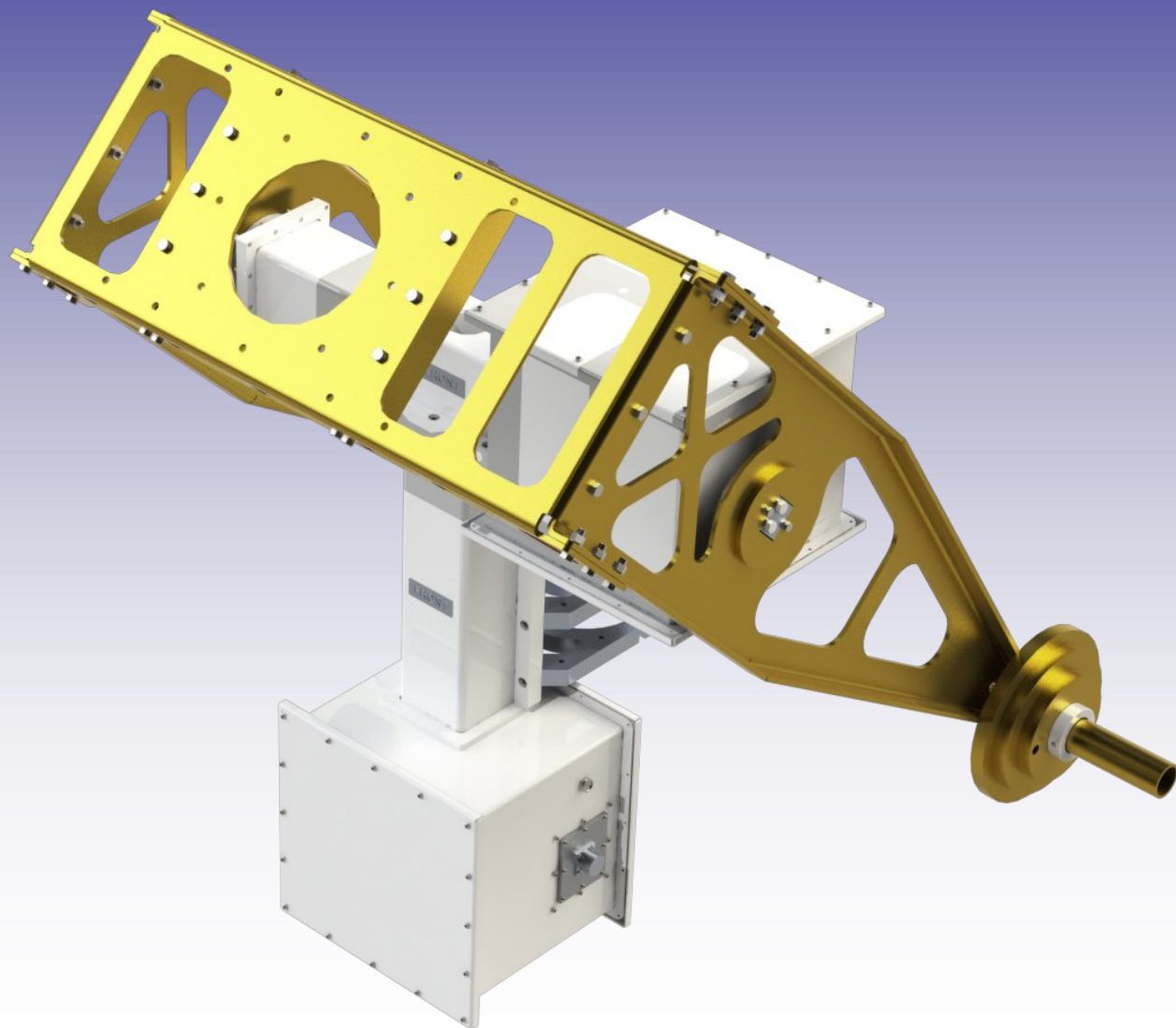

M2 Antenna Systems, Inc.

Model No: FGAE1000-D2-W-D-A-N



SPECIFICATIONS:

Model FGAE1000-D2-W-D-A-N
Motor Type DC Motor
Worm Gear Configuration Double
Enclosure Type Weatherproof

Mount Style Satellite Dish
Body Material Aluminum
Environment Control No Heater

SYSTEM OVERVIEW & DIMENSIONS

BEFORE YOU BEGIN: Look over all the DRAWINGS to get familiar with the various parts and assemblies in the system. Tools handy for assembly process: screwdriver, 11/32, 7/16, 1/2, 9/16 and 5/8" spin-tites, end wrenches and/or sockets, measuring tape.

Note:

All installations are unique in some way, which means it's OK to preassemble certain hardware, or rearrange the assembly process to meet specific site requirements. A quick review of the assembly notes and drawings should help firm up the appropriate strategy. Please remember to double-check all hardware for tightness **BEFORE** it becomes inaccessible.

Two containers of zinc paste (Penetrox, Noalox, or equiv.) have been provided to enhance and maintain the quality of all electrical junctions on this system. Apply a thin coat wherever two pieces of aluminum come in contact or any other electrical connections are made. It is also useful on screws and bolt threads as an ANTI SEIZE compound.

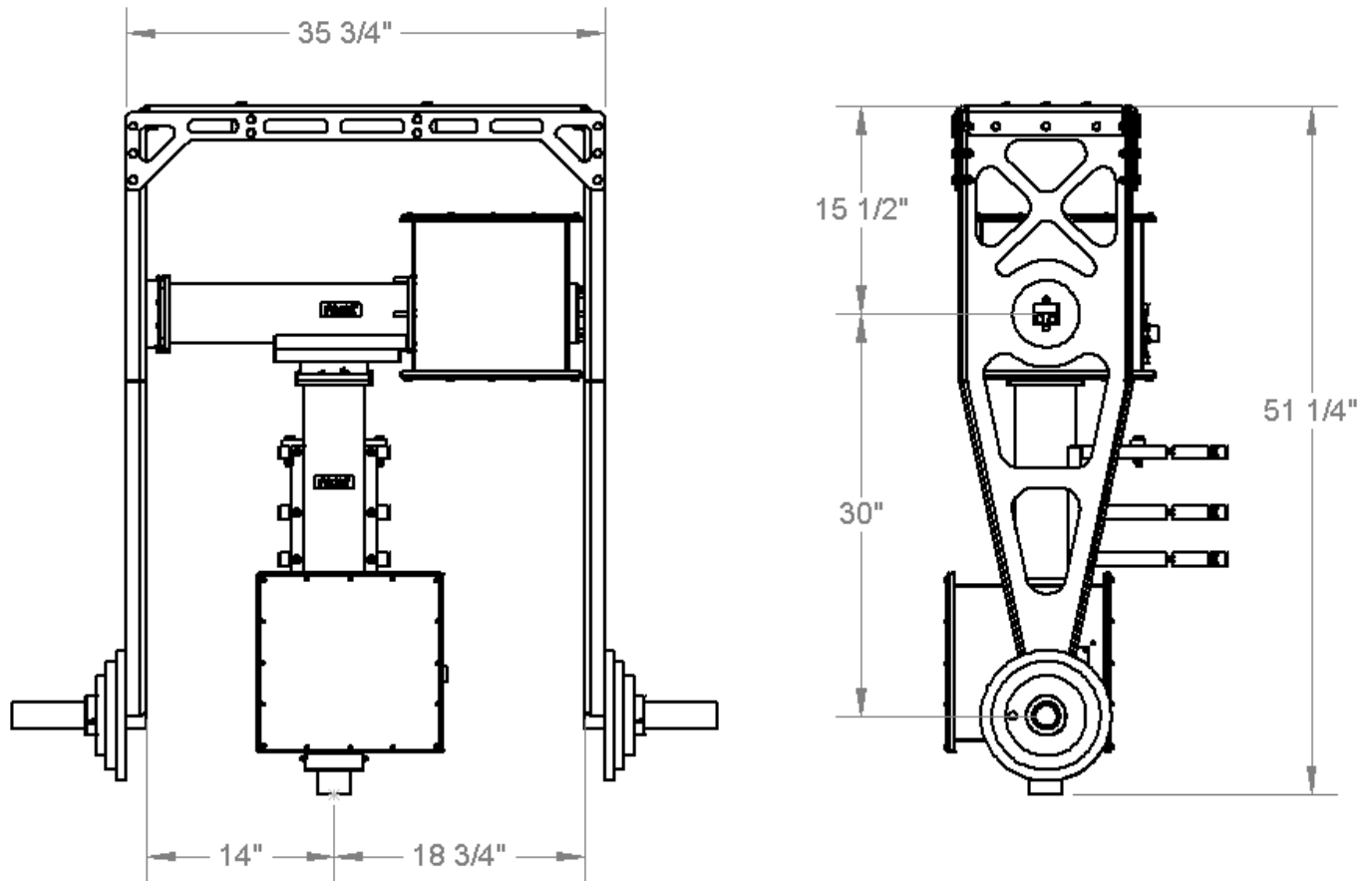

6" PIPE CLAMPS

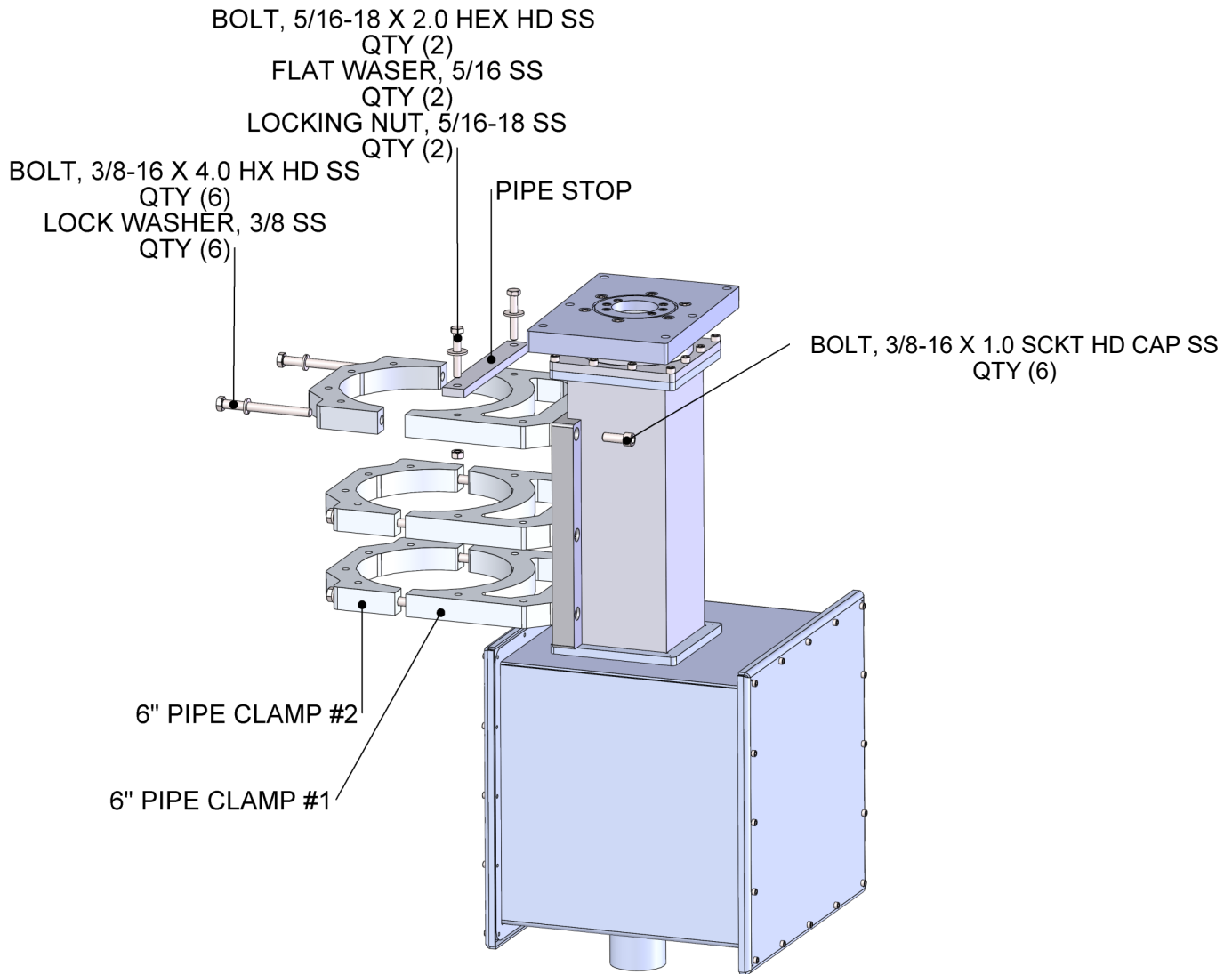

FGAE1000-D2-W-D-A-N ASSEMBLY MANUAL

BOLT, 3/8-16 X 1-1/4", SOCKET HEAD CAP SCREW, SS
QTY (6)

O-RING, BUNA, #153
QTY (1)
INSTALL O-RING PRIOR
TO ATTACHING ELEVATION
ASSEMBLY. THE USE OF
SILICONE GREASE IS HIGHLY
RECOMMENDED

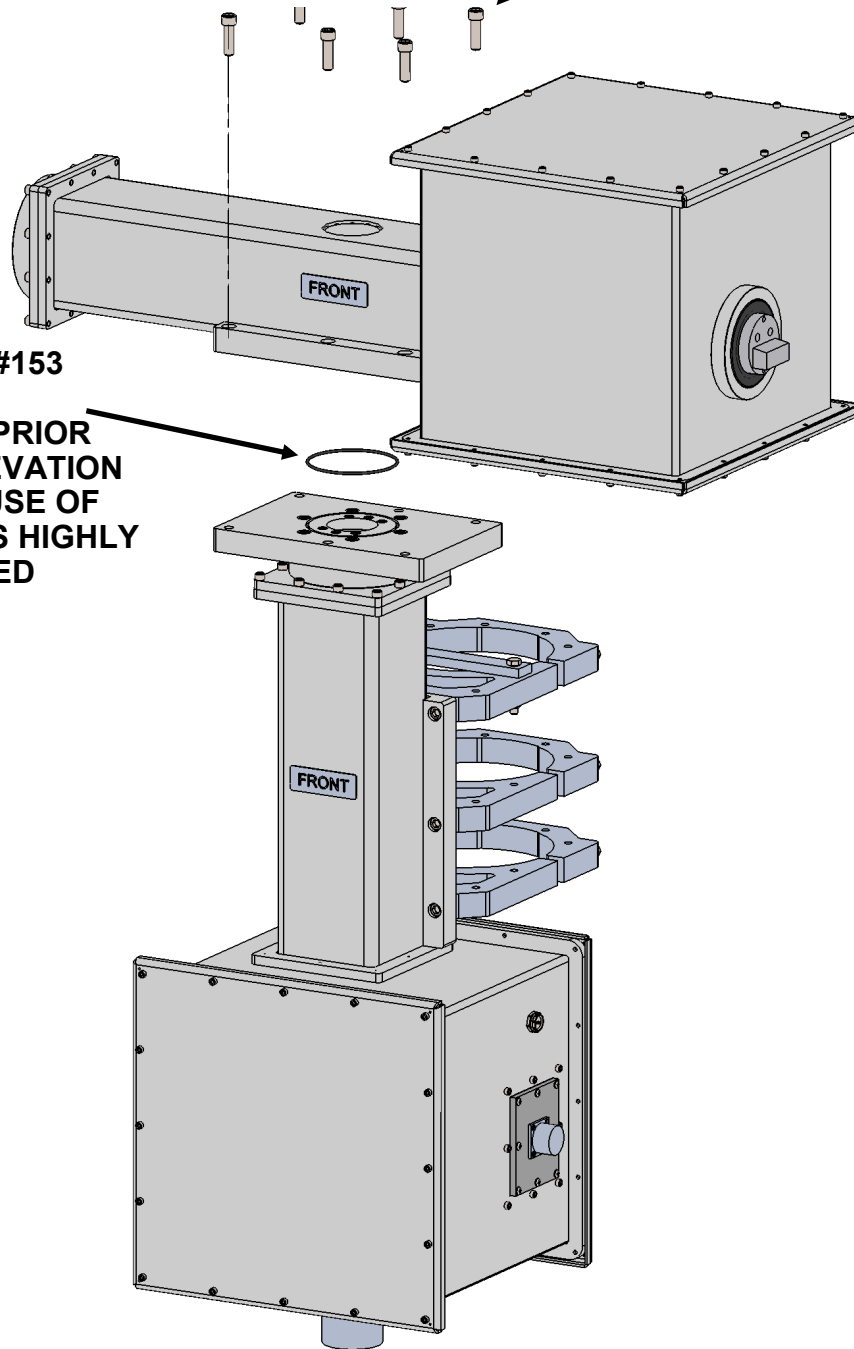

COUNTER BALANCE DRIVE ARM ASSEMBLY

1. INSTALL DRIVE SIDE COUNTER BALANCE ARM USING THE 1/4-20 X 1.0" BOLTS AND LOCK WASHERS. BE SURE TO MATE ARM FACE FLUSH TO THE FACE OF THE DRIVE SPUD.
2. INSTALL LOCKING DOG USING 3/8-24 X 1.500" BOLTS AND LOCK WASHER. TIGHTEN AS NEEDED TO ENSURE NO MOVEMENT IN THE ASSEMBLY JOINT.

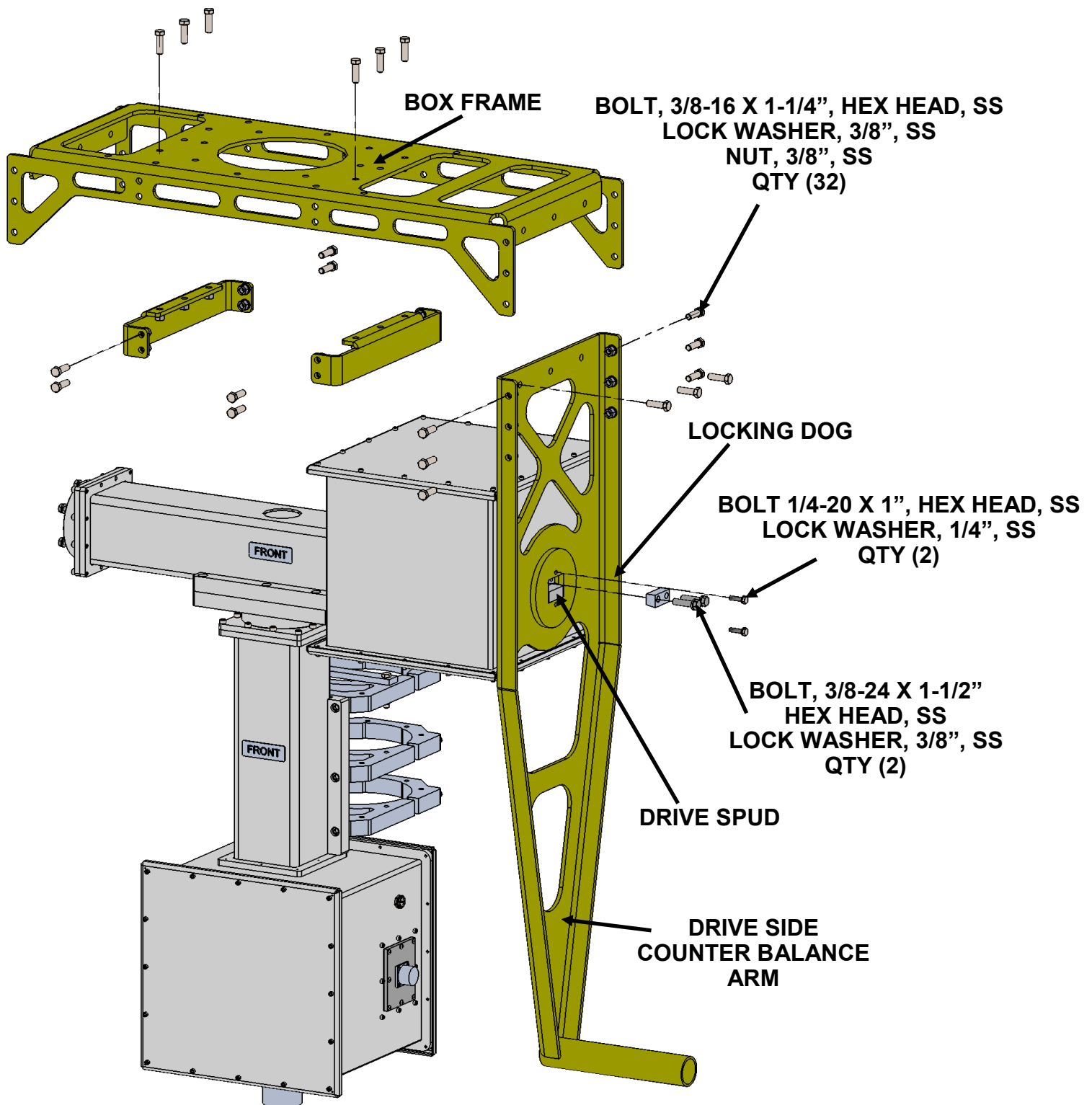

COUNTER BALANCE COAST ARM ASSEMBLY

BOLT, 3/8-16 X 1-1/4", HEX HEAD, SS
LOCK WASHER, 3/8", SS
NUT, 3/8-16", SS
QTY (32)

BOLT, 5/16-18 X 1", HEX HEAD, SS
LOCK WASHER, 5/16", SS
NUT, 5/16", SS
QTY (6)

O-RING
BUNA
#153

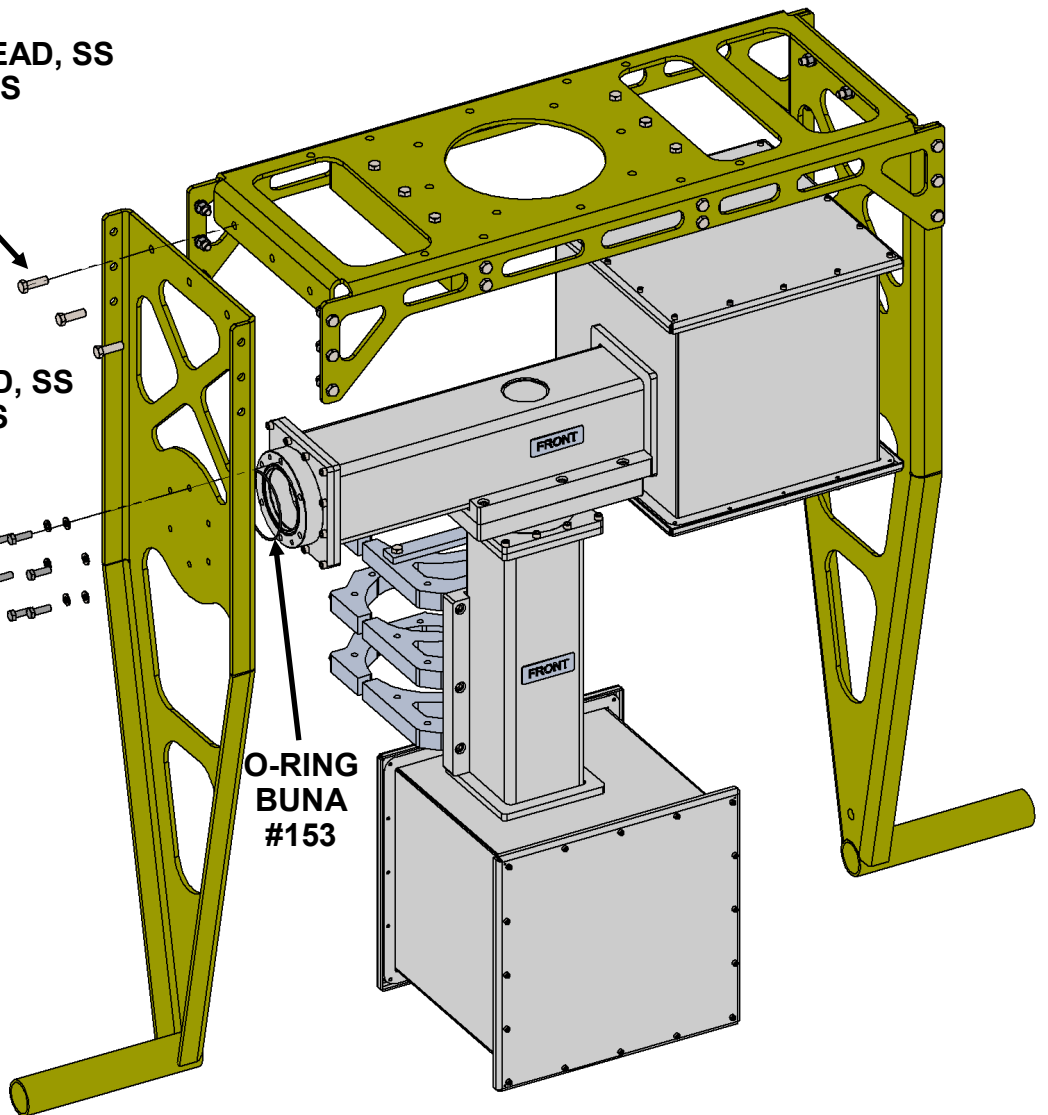

FGAE1000-D2-W-D-A-N PARTS & HARDWARE LIST

<u>DESCRIPTION</u>	<u>QTY</u>
COUNTER BALANCE ARM ASSEMBLY, COAST(SAAE1590)	1
COUNTER BALANCE ARM ASSEMBLY, DRIVE (SAAE1591).....	1
AE1000 ELEVATION ASSEMBLY (SAAE1973)	1
AE1000 AZIMUTH ASSEMBLY (SAAE1974)	1
LOCKING COLLAR (M2AAE1601)	2
DRIVE DOG, COUNTER BALANCE ARM (M2AAE1611)	1
DISH BOX FRAME (M2AAE1619).....	1
COUNTER BALANCE WEIGHT, 5lbs. (M2AAE1625).....	2
COUNTER BALANCE WEIGHT, 10lbs. (M2AAE1626).....	2
COUNTER BALANCE WEIGHT, 15lbs. (M2AAE1627).....	2
BOX FRAME RIB (M2AAE1636).....	2
O-RING, #153	2
7 PIN FEMALE RIGHT ANGLE CONNECTOR ASSEMBLY	2
SHRINK TUBING 1/8" X 4"	2
NYLON TIE, 14"	5
NYLON TIE, 8"	15
PENETROX OR ZINC PASTE (CUP).....	2
 <u>HARDWARE</u>	
BOLT, 3/8-24 X 1-1/2", HEX HEAD, SS	2
BOLT, 3/8-16 X 1-1/4", SOCKET HEAD, SS.....	12
BOLT, 3/8-16 X 1-1/4", HEX HEAD, SS.....	32
BOLT, 3/8-16 X 3/4", SQUARE HEAD, SS	2
LOCK WASHER, 3/8", SS.....	34
NUT, 3/8-16, SS.....	32
BOLT, 5/16-18 X 1", HEX HEAD, SS	6
LOCK WASHER, 5/16", SS.....	6
BOLT, 1/4-20 X 1", HEX HEAD, SS	2
LOCK WASHER, 1/4", SS.....	2
SCREW, 8-32 X 1/2", SET, SS.	4
ALLEN KEY, 5/64".....	1

M² ANTENNA SYSTEMS, INC.

4402 N. Selland Ave.

Fresno, CA 93722

(559) 432-8873 Fax: 432-3059

www.m2inc.com Email: sales@m2inc.com

AZ/EL JUNCTION BLOCK CONNECTIONS

The pictures on this page shows the standard wiring in the junction boxes (with switch reversing diodes) & 7 pin female right angle connector assembly. The system works the following way: Current is constant through the limit switches and through to the positioner. When the limit switch is activated, it breaks the contact and stops the current from continuing. Reversing the positioner in the opposite direction, incorporates directional diodes. Because this is a standard wiring system, there may be variations to this system that may be changed by your specific orientation of each Axis.

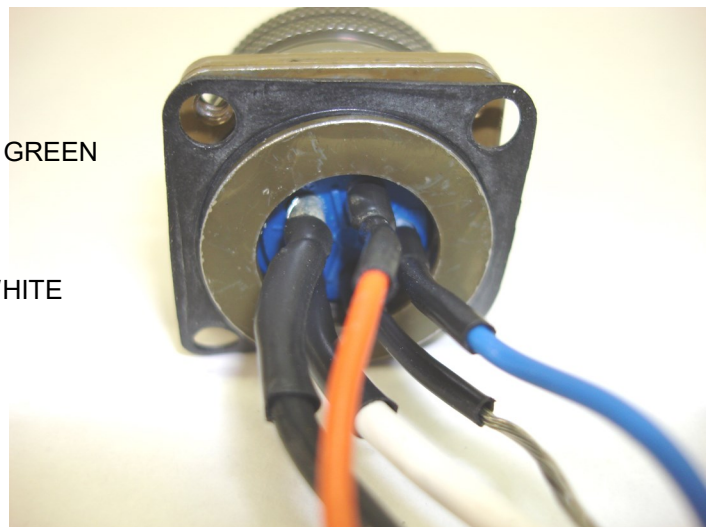
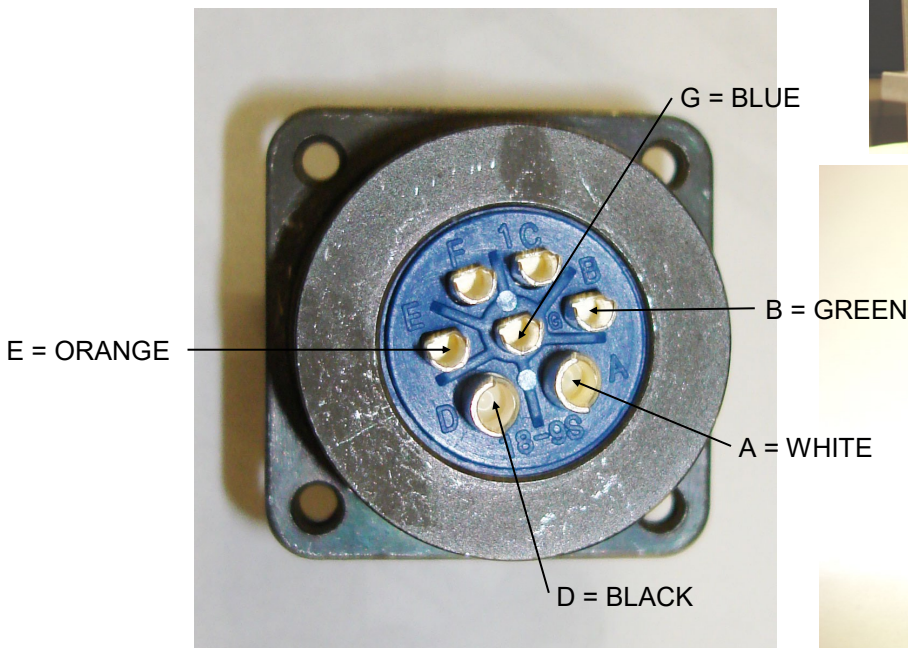
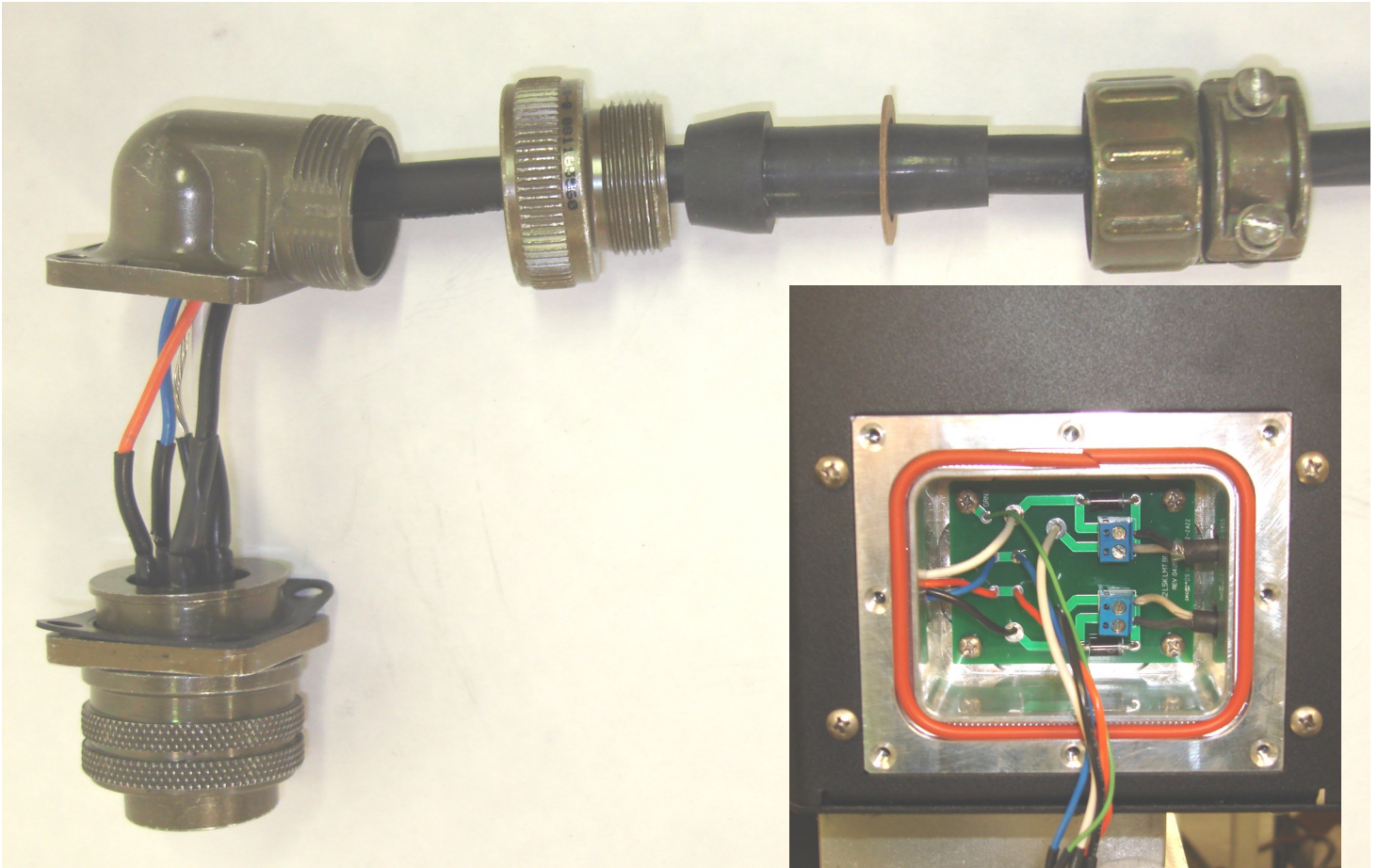

AZ/EL PHYSICAL LIMIT SWITCH TEST

LSK-1000 OVERVIEW:

The **LSK-1000** limit switch kit is a physical hard backup limit. The standard control unit supplied with our AZ or EL has “**Electronic Limits**”, but the **LSK-1000** limit switch kit, has been designed as a physical backup system in the event of a control unit failure. The factory has pre-installed the **LSK-1000** limit switch kit into the AZ and EL units for you. Typically the **LSK-1000** limit switches only need to be setup once, but can be adjusted when necessary.

LSK-1000 MANUAL LIMIT SWITCH PRE-TEST:

Remove one half of the black enclosure from the positioner unit that **DOES NOT** have cord grips or wires running into it. You will see the limit switches (**A,B**) the limit arm (**C**), and limit screw (**D**) as pictured to the right. **We have not installed the limit screw due to unknown customer orientation.** Move the supplied **RC2800** control unit near the positioner for proper limit switch testing. With the positioner wired to the control unit, turn the control unit on. Be sure to test the proper direction of each positioner before moving forward. Once you have determined the correct direction of rotation from the control units’ “Control Buttons,” determine which limit switch will be activated by the rotation of the main gear and limit screw. Press a known direction using the “Control Buttons,” and manually activate the limit switch. At this point the positioner should stop it’s travel. Continue holding the limit switch and reverse the direction using the “Control Buttons.” The motor should move away from the engaged limit switch. This confirms proper wiring and operation of the limit switch. Repeat this procedure for the other direction and limit switch. We suggest, completing each axis (ie Azimuth and Elevation) prior to moving onto the final setup.

AZ/ EL-1000 LIMIT SWITCH ARRANGEMENT

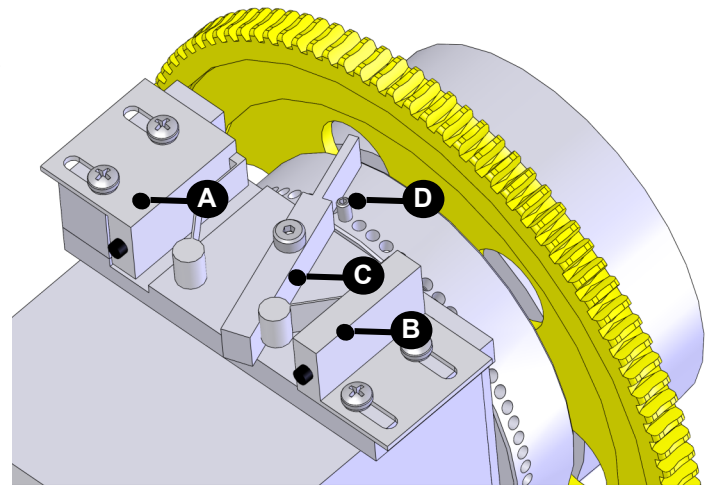

FINAL SETUP OF THE LIMIT SET SCREWS:

We have included (2) limit screws, one for each limit switch. The limit screws can be setup at any position based upon the orientation of your choice. On Azimuth and Elevation use the supplied 8-32 x 1/2” set screws and 5/64 allen wrench. **DO NOT INSTALL AT THIS TIME.** You can always make slight adjustments to the limit screw if necessary. We have provided adjustment holes at every 5°. We suggest leaving the cover off of the unit until you have completed your testing.

MAINTENANCE INFORMATION

90 day maintenance

1. Visual inspection of complete system, look for rust or corrosion and loose hardware.
2. Manually move each axis individually and LISTEN for smooth operation.
3. Check cables for wear and cracking.
4. Check each axis for physical looseness and or backlash (adjust if necessary).
5. Remove covers, check and clean any excessive foreign debris.
6. Grease main gear and worm gear.
7. Lubricate polarity chain with chain lubricant.
8. Check for proper operation of each axis.
9. Replace covers.

1 year maintenance

1. Visual inspection of complete system, look for rust or corrosion and loose hardware.
2. Manually move each axis individually and LISTEN for smooth operation.
3. Check cables for wear and cracking.
4. Check each axis for physical looseness and or backlash (adjust if necessary).
5. Remove covers, check and clean any excessive foreign debris.
6. Check AZ-1000 and EL-1000, thrust block oil-light bearings for wear.
7. Check main load bearings for each individual axis and look for radial slop and or bearing binding.
8. Grease main gear and worm gear.
9. Check physical limit switch operation.
10. Check for proper operation of each axis.
11. Replace covers.

TROUBLESHOOTING

Troubleshooting

1. Motors not moving.

- A. Check for voltage coming out of control box.
- B. Check for voltage at motor (**AZ / EL=42 VDC**).
- C. Check all wiring from control box to motor.
- D. Check motor for binding.

2. No pulse from motors.

- A. Check all wiring from reed switch to control box.
- B. Replace reed switch.

3. Gear binding.

- A. Check Gears for Grease.
- B. Check gear bolts for looseness.
- C. Check gears for foreign debris.
- D. Adjust thrust block adjustment.

4. Excess backlash

- A. Inspect worm and worm gear for wear.
- B. Inspect for thrust block bearing wear.
- C. Inspect system for loose hardware.
- D. Adjust thrust block adjustment.

5. Excess 3" bearing movement

- A. Inspect bearing for radial movement.
- B. Replace 3" bearing assembly.

6. 3" Bearing Binding

- A. Disassemble bearing assembly and inspect for lubrication and foreign debris. Reassemble and test. Replace if necessary.

For more complete maintenance and technical assistance, please contact M2 Antenna Systems, Inc. at **(559) 432-8873**.

AE1000 COVER SEAL FLANGE MAINTAINENCE

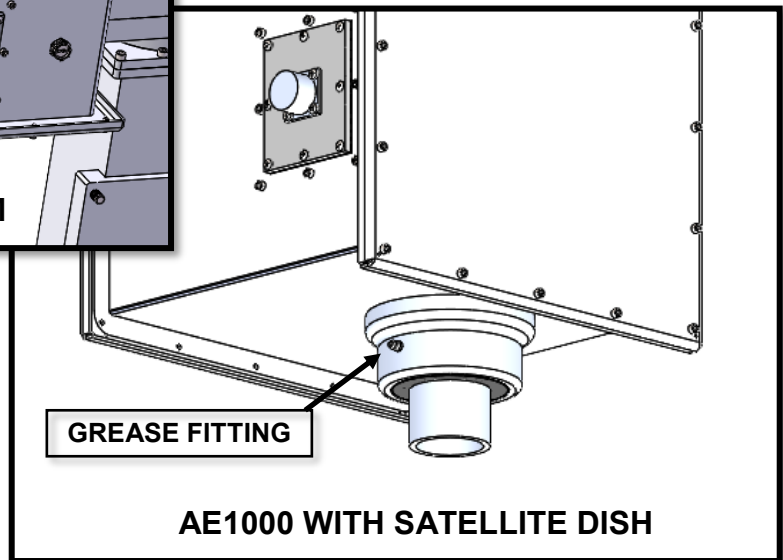
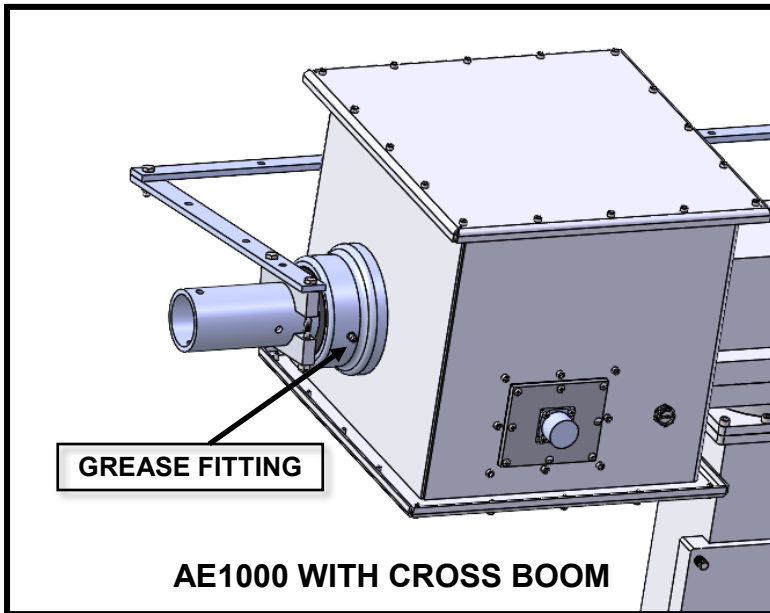

The AE1000 comes with an improved shaft seal that is virtually maintenance free for most applications. The seal comes from the M2 Factory already filled with grease and should last the life of the system under normal weather conditions. Depending on the system the seal will either be on the side of elevation assembly for the cross boom systems or the bottom of the azimuth assembly for satellite dish systems. If the system is installed in harsh weather environments or is constantly being manipulated, periodic check of the grease level may be required. One side of the seal will have a grease fitting and the opposite side will have a grease relief screw. Remove the grease relief screw and using a grease gun insert Lubriplate Mag 1 grease into fitting. Once the proper amount of grease has been filled, grease will flow from the screw hole. Wipe excess grease and replace the relief screw.

WARNING:

Adding grease to the seal without removing the screw will cause damage to the seal.



WORM & WORMGEAR ADJUSTMENT

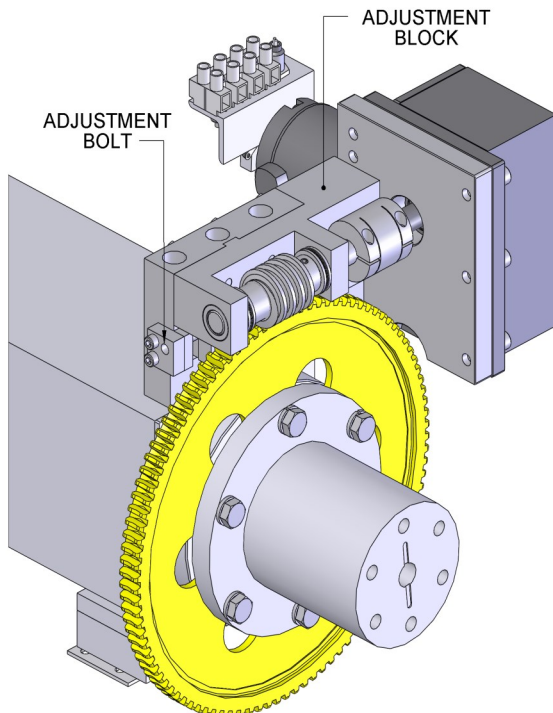
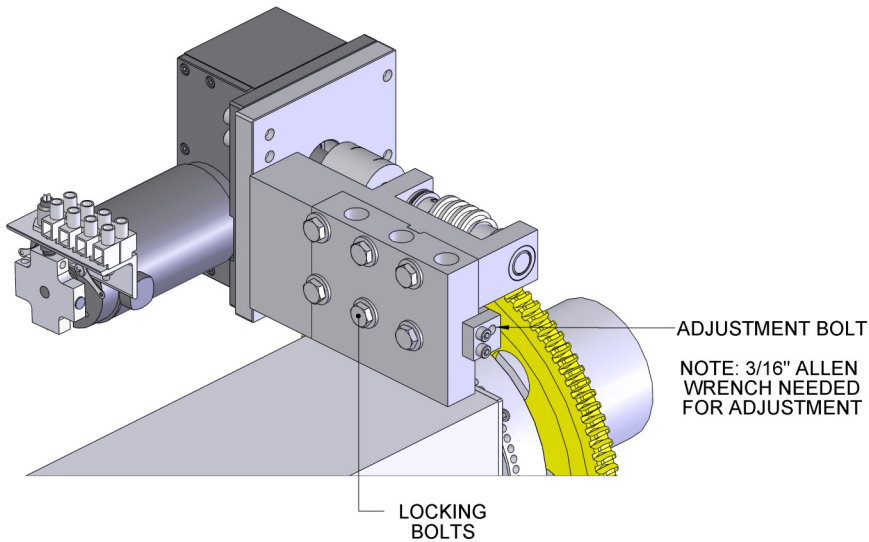

NOTE:
SOME PARTS ARE NOT SHOWN FOR CLARITY

Excessive backlash may develop after using system for some time. We have incorporated a built in backlash adjustment block to keep backlash at a minimum.

Please review drawings shown for more detailed information.

To adjust system:

1. Slightly loosen locking bolts to hand tight.
2. Use a 3/16" Allen wrench to turn adjustment bolt.
3. One full turn of the adjustment bolt will move adjustment block 0.010 of an inch.
4. Clockwise rotation of the adjustment bolt will move the adjustment block down, moving the worm closer to the worm gear and removing backlash.
5. Counter clockwise rotation of the adjustment bolt will move the adjustment block up, moving the worm away from the worm gear and creating more backlash.
6. Adjustments should be made with the motor running. Use the motor drive sound as gauge for friction between worm and worm gear.

Note: Too much friction may cause gear binding in rarely used sections of the worm gear. Some finesse may be required.

7. Tighten locking bolts and test system. Listen for motor running sound for smooth system operation and minimal backlash.

12 Month Limited Warranty Information

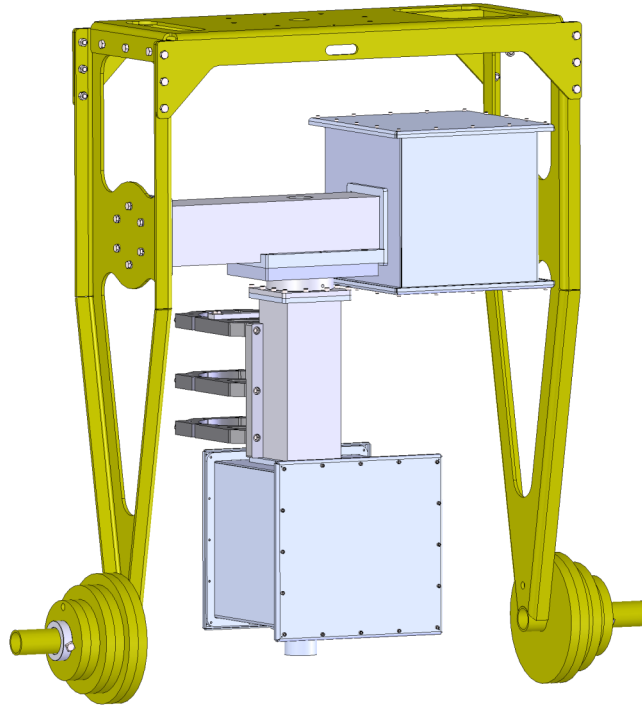

This warranty gives you specific legal rights. You may also have other rights which will vary from state to state or province to province.

M2 warrants the **2-Axis** Positioner unit against defects in material and workmanship for a **period of 12 months** from date of purchase. During the warranty period, **M2** will, at its option, either repair or replace products or components which prove to be defective. The warranty shall not apply to defects or damage resulting from:

- Improper or inadequate maintenance by user
- Improperly prepared installation site
- Unauthorized modifications or misuse
- Accident, abuse, or misapplication
- Normal wear

M2 specifically does not warrant this product for any direct, indirect, consequential, or incidental damages arising from the use or inability to use the product. Some states or provinces do not allow the exclusion or limitation of liability for consequential or incidental damages so the above limitation may not apply.

In the event repair or replacement are necessary, purchaser shall contact M2 for return authorization. In many cases this contact can simplify and expedite the repair / replacement process and help reduce costs and downtime.

The purchaser shall be responsible for packing the product properly for return and for charges to ship the product to **M2**. Always include with the shipment, a statement detailing the problem / failure and any other pertinent observations. Insuring the product for shipment is recommended. Use the original packing materials whenever possible. **M2** is responsible for charges (**in the United States**) to return the repaired / replacement product only where warranty service is involved.