

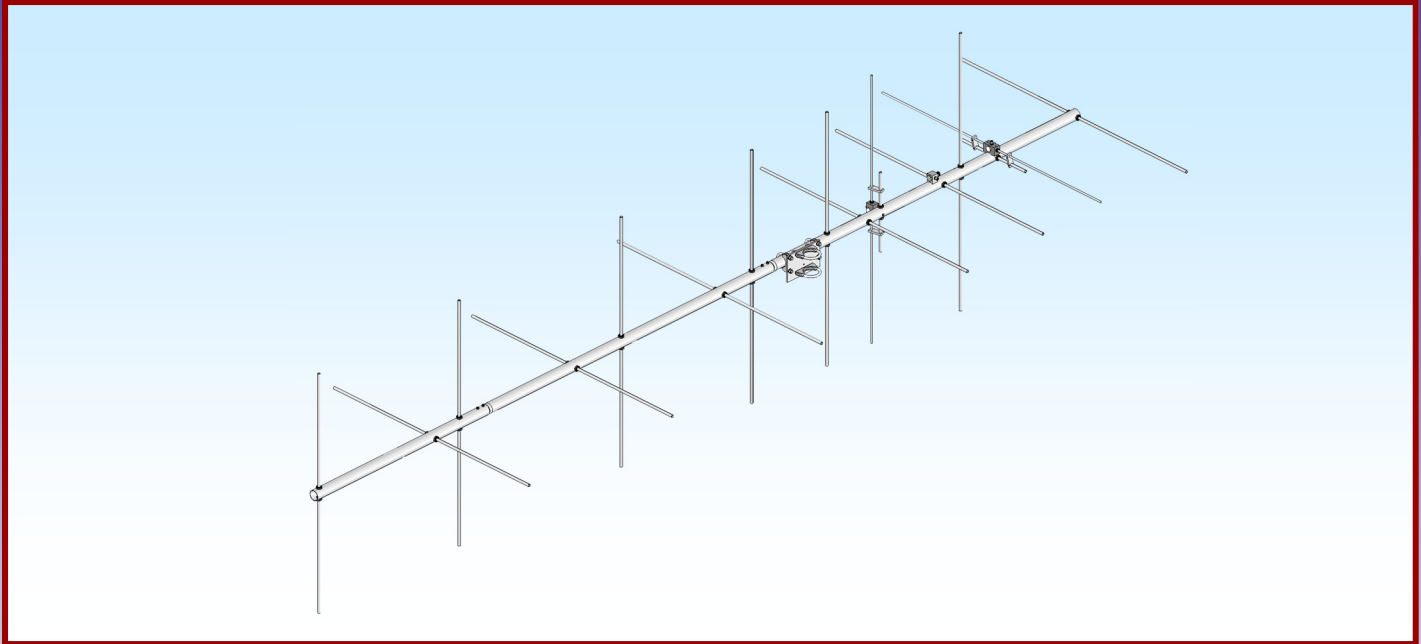

M2 Antenna Systems, Inc.

Model No: 137CP14HD



SPECIFICATIONS:

Model	137CP14HD	Polarity	RHCP
Frequency Range.....	137 To 138 MHz	Power Handling.....	1.5 kW
*Gain, (FS) / 4 spaced 198"	10.5 dBi	Boom Length / Dia	142"/ 1-1/2"
Front to back	19.0 dB Typical	Turning Radius:.....	92"
Beamwidth	34°	Stacking Distance	Call Factory
Feed type	T-Match	Mast Size	2" Nom.
Feed Impedance.....	50 Ohms Unbalanced	Wind area / Survival.....	1.63 Sq. Ft. / 100 MPH
Maximum VSWR.....	1.4 Max	Weight / Ship Wt.	10 Lbs. / 13 Lbs.
Input Connector.....	"N" Female		

***Subtract 2.14 from dBi for dBd / FS = Free Space**

FEATURES:

The 137CP14HD is a mid-sized, performance circular polarized antenna with a remarkably clean pattern. The pattern is important in order to match the antenna's noise temperature with modern low noise preamps. This antenna is ideal for satellite communications. The CNC machined driven element module is O-ring sealed and weather tight for low maintenance and long-term peak performance. Internal connected are encapsulated in a space-age silicone gel that seals out moisture and improves power handling. The 3/16" 6061-T6 rod elements are centered to minimize interaction and maintain good ellipticity. Insulators are UV stabilized and locked in place with stainless keepers. Rugged construction, uncompromising performance: that's the M² 137CP14HD

137CP14HD DIMENSION SHEET

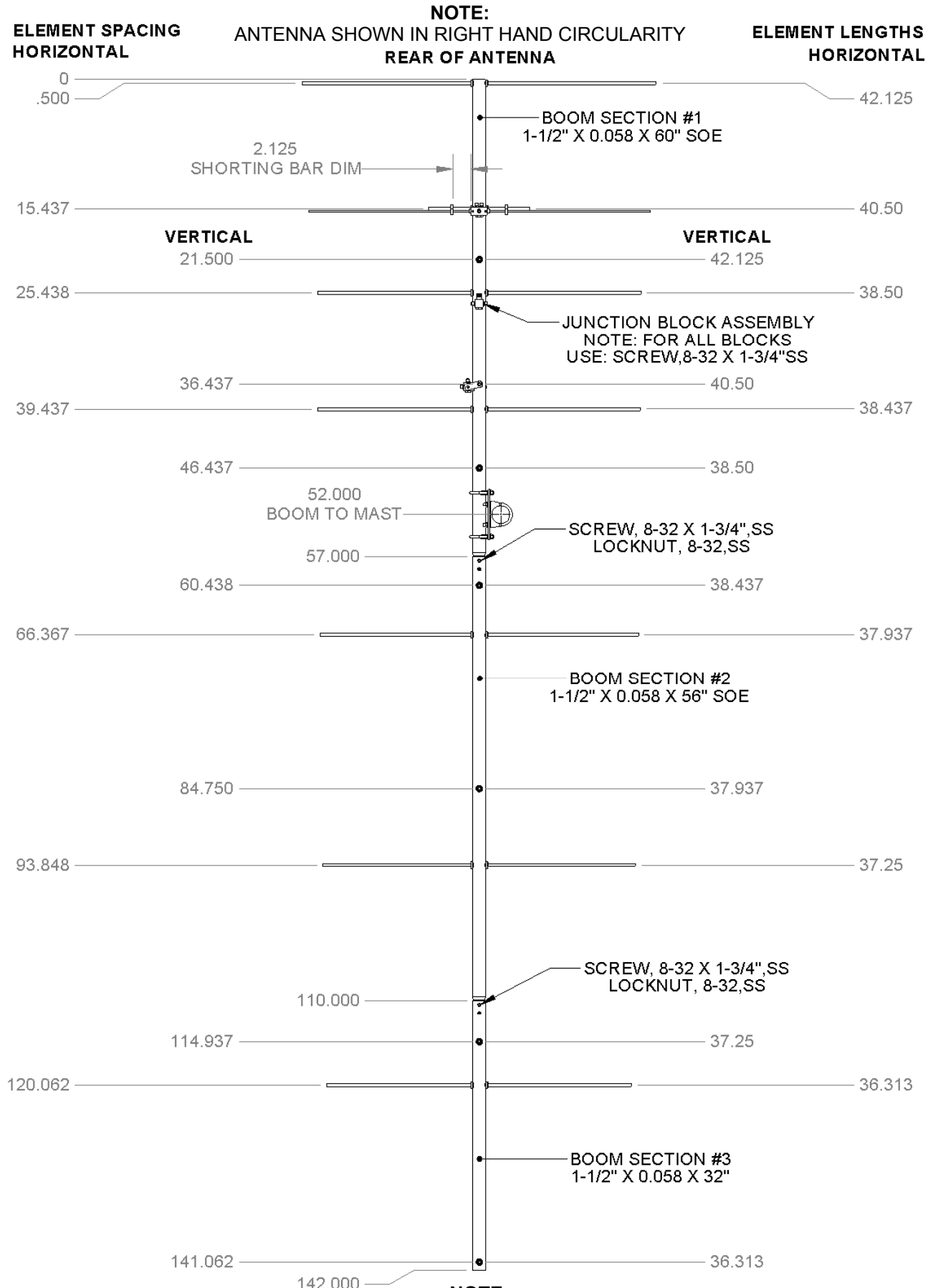

NOTE:
BALUN & PHASING LINES NOT SHOWN FOR CLARITY.

BOOM TO MAST DETAIL

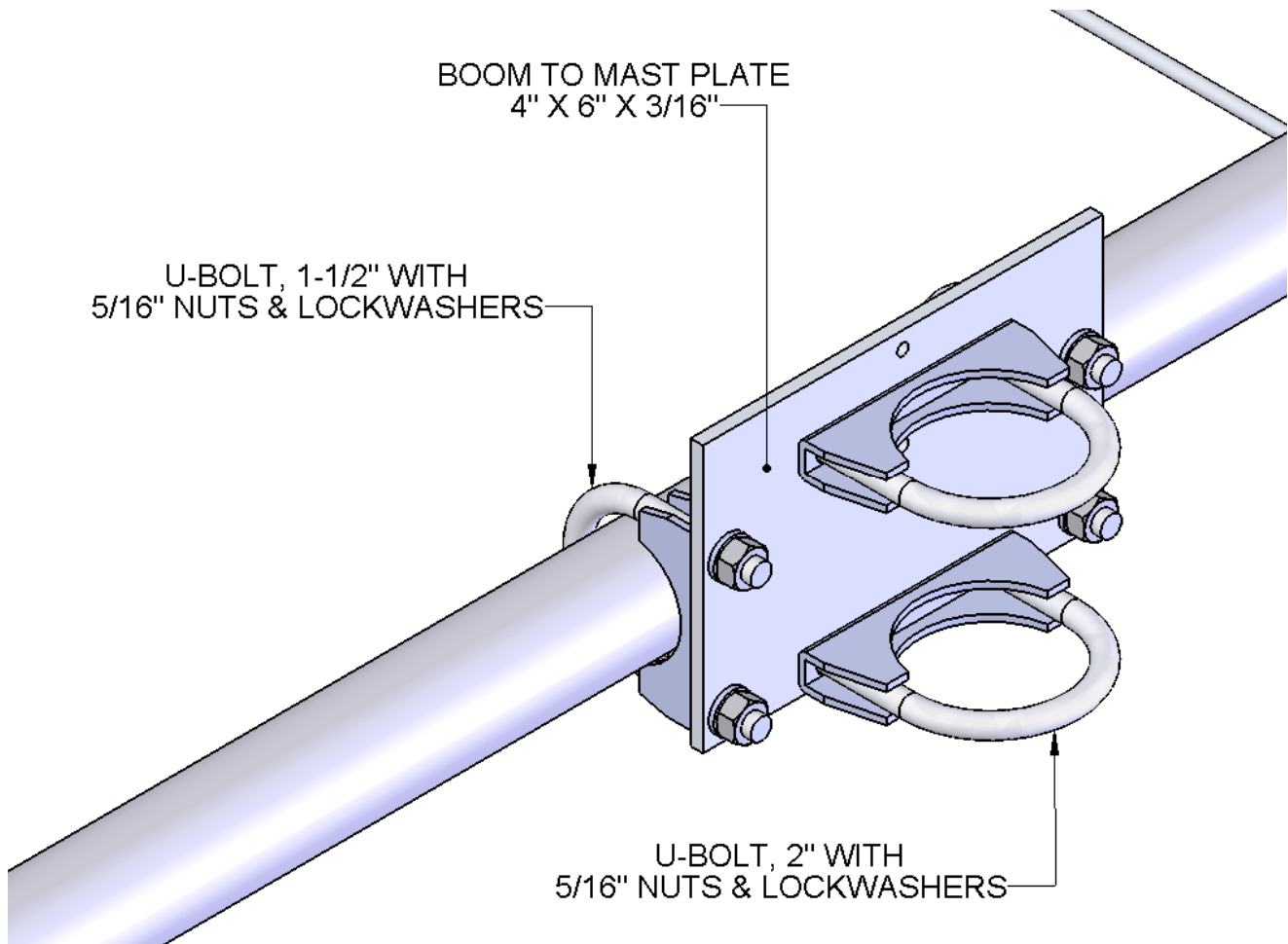

137CP14HD ASSEMBLY MANUAL

TOOL REQUIRED FOR ASSEMBLY: Screwdriver, 11/32 nut driver or wrench, 7/16" and 1/2" end wrenches, pliers, measuring tape.

1. Start by laying out the boom sections, noting hole positions and matching to the DIMENSION SHEET.

2. If you are also using the M² H-frame Kit, open that kit and find one of the 'T' brace clamps shown at right. Loosely install an 8-32 x 1-1/2" screw and locknut into the clamp fingers. Then slide the clamp on the rear boom section (1"). Do not tighten clamp at this time.

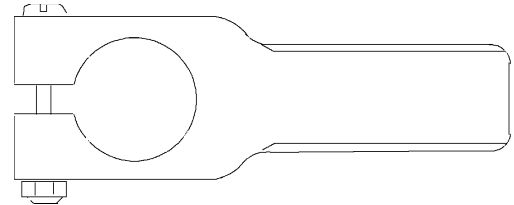

3. Separate elements by length into two sets, "H" (rear) and "V" (forward). Offset between the two element sets is 1/4 wavelength. **Follow the DIMENSION SHEET lengths carefully because SETS ARE NOT IDENTICAL.** Lay out the "H" element set by length and position as shown on the DIMENSION SHEET. Begin with the reflector (longest) element. Balance it across your finger to find rough center and push on a black button insulator to about 1/2" off center.

INSTALLATION TIP FROM MIKE: Because of tolerance in rod diameter, use pliers or equivalent to deform the hole in both button insulators until the rod fits through each tight. This will help hold the elements firmly in place and make it easier to hold the element on center during KEEPER installation.

Insert the element through the hole and install the second button, snugging it up into boom. DO NOT BOTHER TO ACCURATELY CENTER the elements at this time and DO NOT INSTALL the stainless steel shaft retainers. This is easier to do after ALL the horizontal elements are installed in the boom.

4. Install the 3/8" tube DRIVEN ELEMENT as you did the reflector. Then continue with the installation of the DIRECTORS. **Note that the Director Elements do not consistently diminish in length from rear to front, so pay close attention to length and position.**

5. Now begin centering the elements. Use a tape measure to EQUALIZE the length of rod showing on each side of the boom within 1/16 inch. Once you have all the elements centered, sight down the element tips from the rear comparing each side. Look for any obvious discrepancies and correct, if found.

6. **INSTALLING THE SHAFT RETAINERS:** Deburr or chamfer the inside edges of the PUSH TUBE (3/8" x 3" tube, supplied in the kit) to allow the retainer fingers to flex into the tube during installation. Use thumb and forefinger to hold the retainer over the end of the Push Tube with the internal fingers on retainer dished into tube. HOLD THE ELEMENT FIRMLY TO PREVENT IT FROM SLIDING OFF CENTER and press the retainer onto the element end and continue until retainer butts on insulator button. Locking pliers, *lightly* clamped up against opposite button insulator will help maintain center reference (if you push the first retainer too far, remove element from boom, push it completely off the element, and start over). Install another retainer to the opposite side of the element. Continue installing retainers until all elements are locked in place.

NOTE: The SHAFT RETAINERS (used in securing the elements) should always be used for permanent and long term antenna installations. For portable or temporary use, or whenever it is anticipated that the antenna will be disassembled within a short time, the retainers may be left off. The button insulators, normally a tight fit, hold the elements quite securely.

137CP14HD ASSEMBLY MANUAL

7. Mount the **HORIZONTAL DRIVEN ELEMENT BLOCK / ROD ASSEMBLY** to the **TOP** of the boom using a single 8-32 x 1-3/4" screw. Orient the block with the two Balun connectors facing to rear. Install the 8-32 x 1/4" set screws (internal Allen head – tool supplied) into the **SHORTING BARS**. Slide the bars onto the 1/8" driven element tubes and the 1/4" Driven Element Block Rods. Position the Shorting Bars as specified on the **DIMENSION SHEET**. The given dimension is between the outer face of the driven element block and the inner face of the shorting bar. Align the bars with each other and tighten the set screws. (SEE PHOTO BELOW)
8. **ASSEMBLING THE VERTICAL ELEMENTS:** Repeat steps #2 through #5 for the Vertical (forward) elements, using the **DIMENSION SHEET** as your guide to lengths and spacing.
9. **INSTALLATION OF THE VERTICAL DRIVEN ELEMENT BLOCK:** Refer to the **DIMENSION SHEET** for block orientation and Balun direction. All driven element blocks in the final array must be mounted in the same position – such as all horizontal driven element blocks up with Balun to the rear and all vertical blocks on the same side with the Balun going to the rear. Install the shorting bars as specified on the **DIMENSION SHEET**. (SEE PHOTO BELOW)

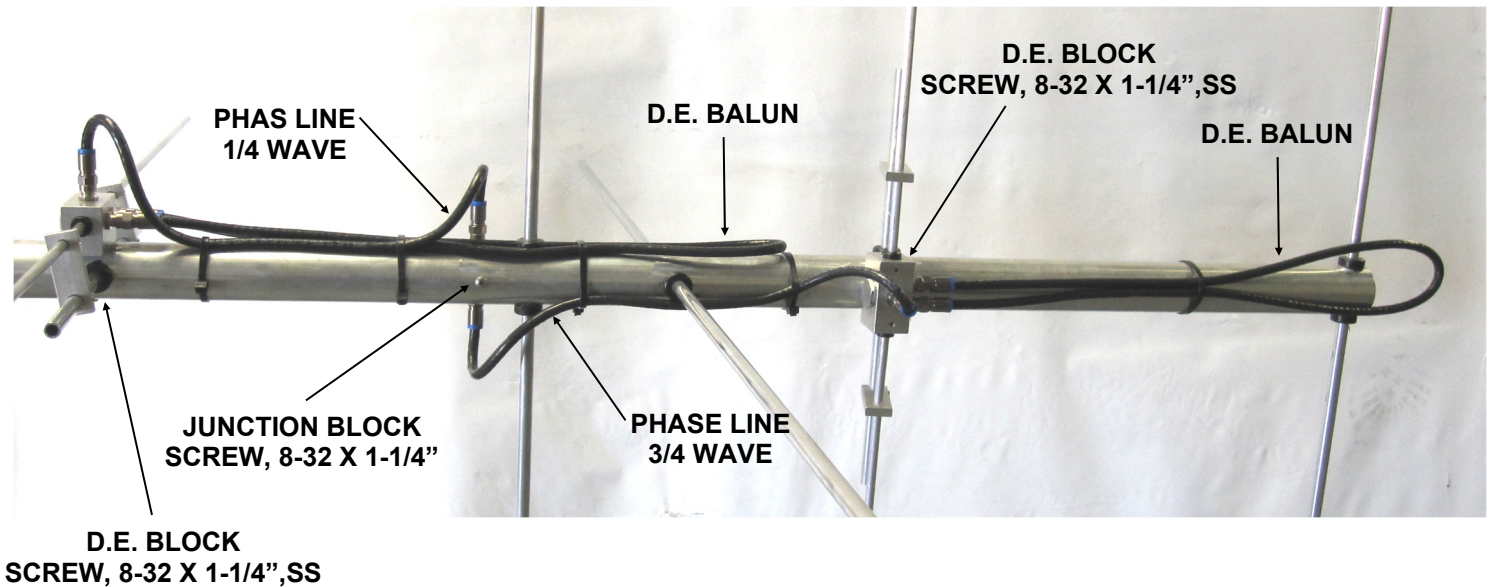

10. Before installing the Baluns, thread 3/8" SEAL NUTS fully onto all connectors, with the black Neoprene side facing out. Attach Baluns to the Driven Element Blocks connectors as shown on the drawing. Coil rear Balun once to keep length on boom. Tighten the connectors **gently** using a 7/16" end wrench. Once the connectors are tight, back the Seal Nuts out and finger-tighten firmly up against the face of the connectors (or tighten **gently** with 1/2" end wrench). A lot of torque is unnecessary. The Vertical Balun may loop around a horizontal element. This is normal. Form Balun coax close to the boom and secure with nylon cable ties. Ties should be snug, but not crushing or kinking the coax.
11. Use top quality coax and "N" connector for your phasing / matching lines. If using with the M² XP H-frame Kit, secure coax near feed connectors on driven element blocks, to provide stress relief, route to 'T' brace clamp, and down 'T' brace tube to power divider. Secure at regular intervals. Refer to H-Frame Manual for important details on orientation of antennas: driven elements must be correctly phased. In homebrew arrays, phasing / matching lines should at least exit from the boom behind, and parallel to, the forward reflector and at right angles to, and slightly forward of, the rear-most driven element. Another alternative is to have both lines exit at the rear of the boom. **Do not route lines forward to boom-to-mast plate as exiting antenna, in any plane, here will adversely affect pattern.**

137CP14HD ASSEMBLY MANUAL

12. The boom to mast plate. (SEE DIMENSION SHEET). The plate on each antenna should be mounted at the identical location. When used in an array, the rear 'T' brace, coax, and power dividers add considerable weight to the rear of the antenna. When used with an M² H-frame Kit, vertical elements are aligned with the boom to mast plate. Secure plate with two 2" U-bolts and the stainless nuts and lock washers provided. DO NOT OVER TIGHTEN. 2" and U-bolts and stainless hardware are provided for mounting the antenna to a NON-CONDUCTIVE mast or crossboom.

13. The 137CP14HD ANTENNA creates a field in all planes or polarities. PERFORMANCE DETERIORATES SIGNIFICANTLY if it is mounted to a metal (conductive) mast / cross boom or if the feedline exits the boom anywhere but at the rear. A 2" mast of any NON-CONDUCTIVE material can be used. Fiberglass is the prime choice for its strength and weather resistance. Array hardware that does not intersect or intrude on the element planes may be of conductive material; for instance, the main crossboom in a 4- or 8-bay array or the center 5-6 feet of the vertical support masts.

14. Orientation of multiple antennas in an array is critical to optimum performance. If using with See the attached array harnessing, spacing, and hardware arrangement drawing if using with the M² H-frame Kit. (PLEASE SEE H-FRAME MANUAL FOR MORE INFORMATION)

M² ANTENNA SYSTEMS, INC.
4402 N. SELAND AVE.
FRESNO, CA 93722
(559) 432-8873 FAX: 432-3059
www.m2inc.com Email: sales@m2inc.com

137CP14HD PARTS & HARDWARE

DESCRIPTION	QTY
#1 BOOM SECTION, 1-1/2 X .058 X 60" SOE	1
#2 BOOM SECTION, 1-1/2 X .058 X 56" SOE.....	1
#3 BOOM SECTION, 1-1/2 X .058 X 32" STR	1
ELEMENTS, 3/8 Tube X Dimension Sheet	14
DRIVEN ELEMENT BLOCK ASSEMBLY	2
JUNCTION BLOCK ASSEMBLY	1
BALUN, RG-6 X 36" (1/2 WAVE)	2
PHASE LINE, RG-6 (1/4 WAVE).....	2
BOOM-TO-MAST PLATE, .188 X 6 X 4" (M2APT0022)	1
U-BOLT AND CRADLE, 2"	2
U-BOLT AND CRADLE, 1-1/2"	2
ASSEMBLY MANUAL	1

IN HARDWARE BAG:

SHORTING BAR (M2ASB0320).....	4
BUTTON INSULATORS, 3/8.....	28
KEEPER, 3/8, SS	28
NUT, 5/16-18 SS	8
LOCKWASHER, 5/16 SS	8
SCREW, 8-32 X 1-3/4", SS	7
LOCKNUT, 8-32 SS	7
SET SCREW, 8-32 X 1/4 SS.....	8
CABLE TIE, NYLON	6
SEAL NUTS	8
ALLEN HEAD WRENCH	1
PUSH TUBE, 3/8 X 3"	1

STR = STRAIGHT TUBE
SOE = SWAGED ONE END
SBE = SWAGED BOTH ENDS

M² ANTENNA SYSTEMS, INC.
4402 N. SELLAND AVE.
FRESNO, CA 93722
(559) 432-8873 FAX: 432-3059
www.m2inc.com Email: sales@m2inc.com