

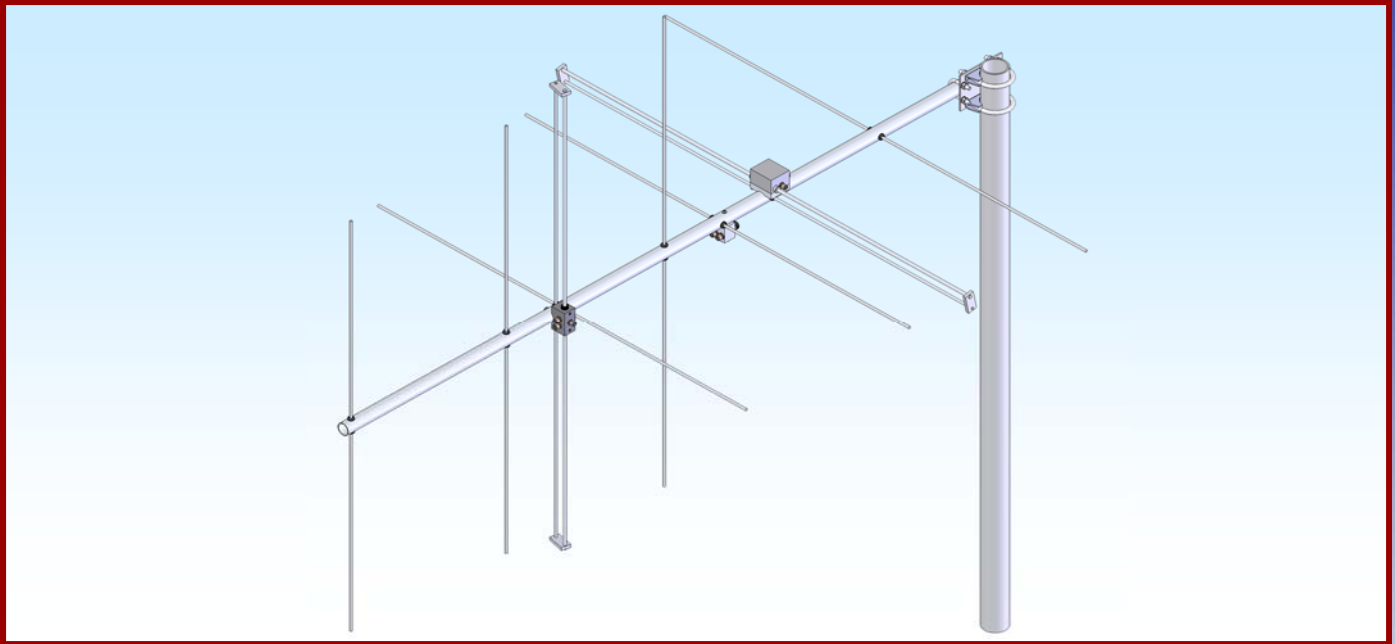

M2 Antenna Systems, Inc.

Model No: 146CP8



SPECIFICATIONS:

Model	146CP8	Power Handling	1 kW
Frequency Range.....	144 To 150 mHz	Boom Length / Dia.....	63" / 1"
*Gain	8.5 dBic	Maximum Element Length.....	40-3/8"
Front to back	17 dB Typical	Turning Radius:	61"
Beamwidth	E=70° H=70°	Stacking Distance.....	56" High & 56" Wide
Feed type	"T" Match	Mast Size.....	1-1/2" to 2" Nom.
Feed Impedance.	50 Ohms Unbalanced	Wind area / Survival	0.47 Sq. Ft. / 100 MPH
Maximum VSWR.....	1.5:1 Typical	Weight / Ship Wt.....	4 Lbs. / 6 Lbs.
Input Connector.....	"N" Female		

***Subtract 2.14 from dBi for dBd**

FEATURES:

The 146CP8 is a practical sized, yet high performance circular polarized antenna with a remarkably clean pattern. The pattern is important in order to match the antenna's noise temperature with modern low noise preamps. This antenna is ideal for satellite work.

The CNC machined driven element module is O-ring sealed and weather tight for low maintenance and long-term peak performance. Internal connected are encapsulated in a space-age silicone gel that seals out moisture and improves power handling. The 3/16" 6061-T6 rod elements are centered to minimize interaction and maintain good ellipticity. Insulators are UV stabilized and locked in place with stainless keepers. Rugged construction, uncompromising performance for the boomlength: thats the M² 146CP8!

146CP8 ASSEMBLY MANUAL

TOOL REQUIRED FOR ASSEMBLY: screwdriver, 11/32 nut driver or wrench, 7/16" and 1/2" socket or end wrenches, measuring tape.

ASSEMBLING THE HORIZONTAL ELEMENTS

1. Lay out the elements by "HORIZONTAL" length and position as shown the DIMENSION SHEET. Start with the reflector (longest) element. Balance it on your finger to find rough center and push on a black button insulator to about 1/2" off center. **DO NOT BOTHER CENTERING** the element at this time and **DO NOT INSTALL** the stainless steel shaft retainers yet. It is easier to do it after all the horizontal elements are installed in the boom.
2. Install the 3/16" rod DRIVEN ELEMENT as you did the reflector. Then continue with the installation of the DIRECTORS. **Note that the Director Elements do not consistently diminish in length from rear to front, so pay close attention to length and position.**
3. Now begin centering the elements. Use a tape measure to EQUALIZE the amount the element sticking out on each side of the boom. Once you have all the elements centered, sight down the element tips from the rear comparing each side. Look for any obvious discrepancies and correct if found.

4. Stainless steel SHAFT RETAINERS lock the elements in place. They should always be used for permanent and long term antenna installations. For portable or temporary use, the button insulators are adequate for holding the elements and the retainers may be left off.

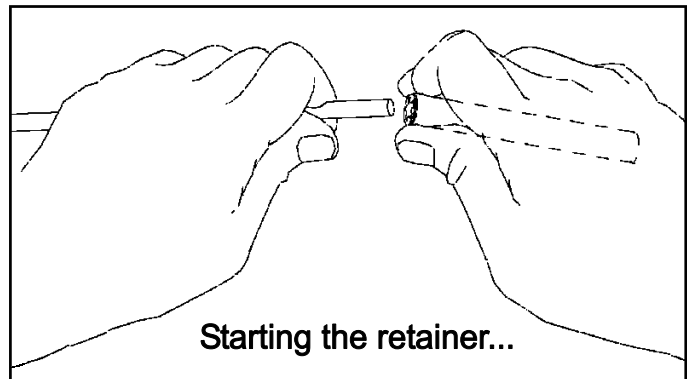

To install the stainless steel SHAFT RETAINERS, use thumb and forefinger to hold the retainer over the end of the PUSH TUBE 3/8" x 3" tube, (supplied in the kit), internal fingers on retainer dished into tube. HOLD THE ELEMENT FIRMLY TO PREVENT IT FROM SLIDING OFF CENTER and press the retainer onto the element end and continue until retainer

butts on to insulator button. Locking pliers, *lightly* clamped up against opposite button insulator will help maintain center reference (if you push the first retainer too far, remove element from boom, push retainer completely off the element, and start over). Install another retainer to the opposite side of the element. Continue installing retainers until all elements are secured.

5. Mount the **HORIZONTAL** DRIVEN ELEMENT BLOCK / ROD ASSEMBLY to the **top** of the boom using a single 8-32 X 1-1/4" screw. Orient the block with the two balun connectors facing to rear.
6. Install the 8-32 x 1/4" set screws (internal Allen head - tool supplied) into the SHORTING BARS. Slide the bars onto the 1/4" Driven Element Block Rods and the 3/16" driven element rod. **Position the Shorting Bars as described on the dimension sheet.** Align the bars with each other and tighten the set screws.

ASSEMBLING THE VERTICAL ELEMENTS

Note: The vertical element set is shifted forward on the boom by 1/4 wavelength. This increases isolation between element planes, improving circularity and ease of phasing / matching the two element sets.

7. Repeat steps #1 through #6 for the Vertical elements, using the Dimension Sheet as your guide to lengths and spacing.

INSTALLATION OF THE VERTICAL DRIVEN ELEMENT BLOCK DETERMINES THE CIRCULARITY OF THIS ANTENNA. THE ORIENTATION OF THE BLOCK FOR RHC - RIGHT HAND CIRCULARITY, IS SHOWN ON THE DIMENSION SHEET.

8. Viewed from the rear of the boom (rearmost Reflector HORIZONTAL), the VERTICAL Driven Element Block mounts to the LEFT hand side of the boom with the two Balun connectors oriented to the FRONT. Secure with 8-32 x 1-1/4" screw. Install the Shorting Bars as in step #6.

146CP8 ASSEMBLY MANUAL

9. Before installing the Baluns and Matching / Phasing Harness, thread 3/8" SEAL NUTS fully onto all connectors, with the black Neoprene face of the nuts facing out. Attach Baluns and Phasing lines to the Driven Element Blocks and Junction Block as shown on the Dwg. Tighten the connectors **gently** using a 7/16" end wrench. Once the connectors are tight, back the Seal Nuts out and finger-tighten firmly up against the face of the connectors (or tighten **gently** with 1/2" end wrench). A lot of torque is unnecessary. Depending on model and polarity, the Vertical balun may loop around another element. This is normal. Form balun coax until it is close to the boom and secure with a nylon cable tie. Also secure the other balun and the matching / phasing harness coax with cable ties. Ties should be snug but not crushing or kinking the coax.
10. Use good quality coax and "N" connector for your feedline (see Installation Tips). Secure feed coax near connector on Junction Block, to provide stress relief. Allow about 60" of coax to hang in a loop between the rear end of the boom and the reattachment point (at least 12" beyond element tips) on the mast or crossboom.



11. The boom to mast plate is normally mounted to the boom at the balance point. Note: Some antennas are rear mounted. Since the feed line represents significant weight it is best to have it attached and fastened to the boom with cable ties before final mounting the plate. Use two 1" U-bolts and the stainless nuts and lock washers provided. **DO NOT OVER TIGHTEN.** 1-1/2" and 2" U-bolts (and stainless steel nuts / lock washers) are provided for mounting the antenna to your NON-CONDUCTIVE mast or crossboom.

THIS COMPLETES THE ANTENNA ASSEMBLY.
(SEE INSTALLATION TIPS PAGE)

146CP8 INSTALLATION TIPS & HINTS

1. The 146CP8 is a circular polarized antenna and creates a field in all planes or polarities. Performance DETERIORATES SIGNIFICANTLY if it is mounted on a metal (conductive) mast or crossboom. A mast or crossboom of any NON-CONDUCTIVE material must be used. Fiberglass is the prime choice for its strength and weather resistance. Mount the 146CP8 so that element tips are at least 12" from any conductive material (mast, tower, feedline, etc.).
2. Recommended feedlines, in order of preference:
 Andrews or Celwave 1/2" hardline
 Times LMR-400 or Belden 8214
 Try to keep the cable run to under 100 ft. to prevent excessive signal loss.
3. To maintain proper phasing when stacking two or more antennas, mount each with the same orientation of Driven Element Blocks. DO NOT MOUNT IN MIRROR IMAGE. See the Specification Sheet for stacking distances. For more detailed stacking information contact M².

CAREFULLY MANUFACTURED BY:
M² ANTENNA SYSTEMS, INC.
4402 N. Selland Ave.
Fresno, CA 93722
(559) 432-8873 Fax: 432-3059
www.m2inc.com Email: sales@m2inc.com

146CP8 DIMENSION SHEET

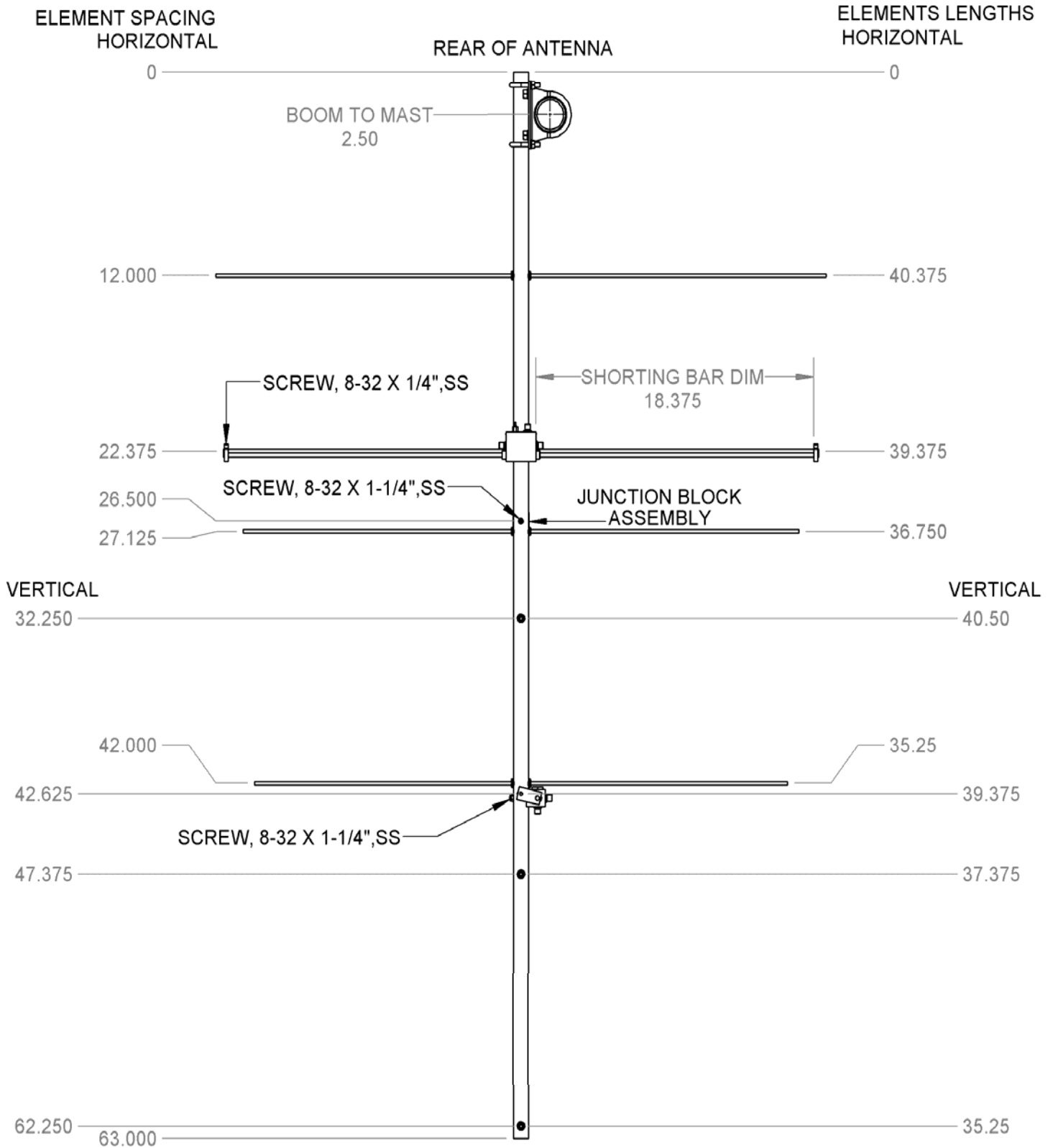

NOTE:
 PHASE LINES TO JUNCTION BLOCK
 & BALUNS NOT SHOWN FOR CLARITY.
 SEE BALUN & PHASE LINE PICTURE
 FOR MORE INFORMATION.

146CP8 PARTS & HARDWARE

DESCRIPTION.....	QTY
BOOM SECTION # 1" X 0.058 X 63" (WITH 7/8" SLEEVE).....	1
ELEMENTS, 3/16" ROD x SEE CUT SHEET	8
PS DRIVEN ELEMENT ASSEMBLY (CUSTOM)	1
DRIVEN ELEMENT ASSEMBLY	1
BALUN, RG-6 1/2 λ	2
PHASE LINE, RG-6 1/4 λ	2
JUNCTION BLOCK ASSEMBLY (SADE0065).....	1
BOOM-TO-MAST PLATE, 3 X 4 X .125" (M2APT0019)	1
SHORTING BAR, VHF, 1/4" X 3/4" (M2ASB0090).....	4
U-BOLT & CRADLE, 2".....	2
U-BOLT & CRADLE, 1-1/2"	2
U-BOLT, 1".....	2
ASSEMBLY MANUAL.....	1

HARDWARE:

BUTTON INSULATOR.....	16
SHAFT RETAINER, SS	16
NUT, 5/16-18 SS.....	4
LOCKWASHER, 5/16 SS.....	4
NUT, 1/4-20 SS.....	4
LOCKWASHERS, 1/4 SS	4
SCREW, 8-32 X 1-1/4 SS	3
SETSCREW, 8-32 X 1/4, SS	8
CABLE TIE, (MEDIUM).....	4
SEAL NUTS, 3/8-32.....	8
ALLEN HEAD WRENCH, 5/64"	1
PUSH TUBE, 3/8 X 3"	1

M² ANTENNA SYSTEMS, INC.

4402 N. Selland Ave.

Fresno, CA 93722

(559) 432-8873 Fax: 432-3059

www.m2inc.com Email: sales@m2inc.com