

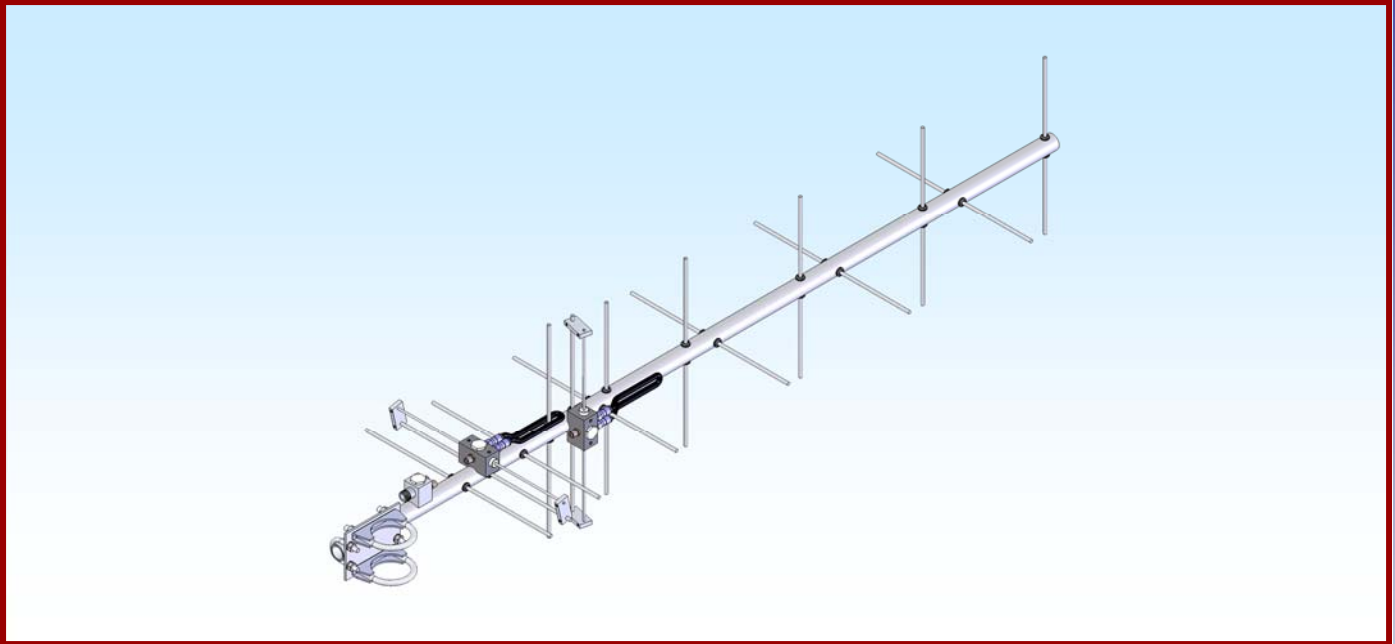

M2 Antenna Systems, Inc. Model No: 401CP14



SPECIFICATIONS:

Model	401CP14	Power Handling	600W
Frequency Range.....	400-415 MHz	Boom Length / Dia.....	49" / 1" Dia
*Gain	11.50 dBi	Parasitic Elements.....	14, 3/16" Rod
Front to back	22 dB Typical	Stacking Distance.....	24"
Ellipticity	1.5 dB Typical	Mast Size.....	1-1/2- 2 Inch
Beamwidth	60° circular	Wind area / Survival	7 sq ft.
Feed Impedance.....	50 Ω , Unbalanced	Weight / Ship Wt.....	4 lbs / 7 lbs UPS
Maximum VSWR.....	1.6:1 Max		
Input Connector.....	"N" Female		

***Subtract 2.14 from dBi for dBd**

FEATURES:

The 401CP14 is a practical sized, yet high performance circular polarized antenna with a remarkably clean pattern. The pattern is important in order to match the antenna's noise temperature with modern low noise preamps. This antenna is ideal for satellite work but is also excellent for terrestrial use. The CNC machined driven element module is O-ring sealed and weather tight for low maintenance and long-term peak performance. Internal connected are encapsulated in a space-age silicone gel that seals out moisture and improves power handling. The 3/16" 6061-T6 rod elements are centered to minimize interaction and maintain good ellipticity. Insulators are UV stabilized and locked in place with stainless keepers. Rugged construction, uncompromising performance for the boom length.

401CP14 ASSEMBLY MANUAL

TYPICAL TOOLS REQUIRED: measuring tape, phillips screwdriver, 5/16", 11/32, 7/16, and 1/2 spin-tite, end wrenches and / or sockets. Heavy duty models may require larger sizes.

1. Lay out the boom sections and assemble using the DIMENSION sheet as a guide for position and hardware.
2. **Cut a strip of masking tape about 6" long. Fold the ends under and stick the tape to a flat surface, sticky side up.** Lay out the elements by length and position as shown the DIMENSION sheet. NOTE: THE ELEMENTS IN THIS ANTENNA DO NOT ALL TAPER IN LENGTH. Now lift off the REFLECTOR and find the rough center by balancing it across finger. Push on a black button insulator to about 1/2" from center. Insert the element through the holes at the rear of the boom and install the second button. IF THE ELEMENT IS LOOSE IN THE BUTTONS, SQUEEZE THE SMALL END OF EACH BUTTON SLIGHTLY WITH PLIERS UNTIL IT OFFERS SIGNIFICANT RESISTANCE WHEN THE ELEMENT IS INSERTED. THIS WILL HELP TO HOLD THE ELEMENT IN POSITION DURING SUBSEQUENT OPERATIONS. Install the 3/16" rod DRIVEN ELEMENT as you did the reflector. Then continue with the installation of the DIRECTORS. **Note that the Director Elements may not consistently diminish in length from rear to front, so pay close attention to length and position.**

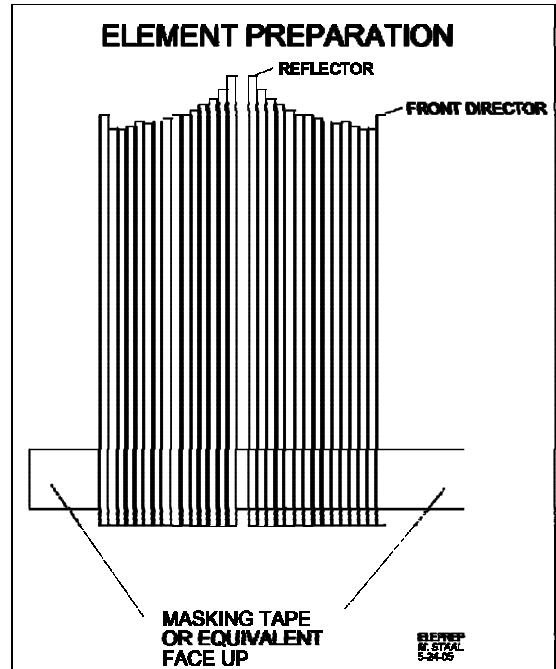

3. Now begin centering the elements. Use a tape measure to EQUALIZE the amount the element sticking out on each side of the boom. Once all are centered, sight down the antenna from the rear and compare tip symmetry. Look for any obvious discrepancies and correct if found.

4. Stainless steel SHAFT RETAINERS are used for securing the elements and insulators. Always use retainers for permanent and long term antenna installations. For most portable or temporary use, the button insulators are satisfactory and the retainers may be left off.

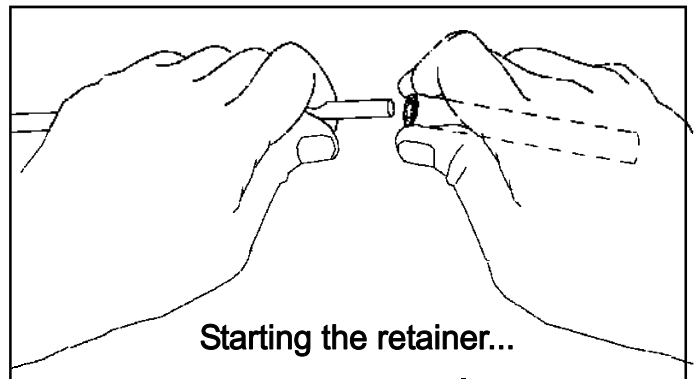

5. Use thumb and index finger to hold a Shaft Retainer over end of the 3/8 x 3" push tube (internal fingers dished into tube). Hold the element firmly and start the keeper onto the rod by applying pressure with the push tube. Push the Shaft Retainer down element until tight against the button insulator (Locking pliers, **lightly** clamped up against opposite button insulator will help maintain center reference and keep you from pushing the first Shaft Retainer too far). Repeat for the opposite side. Continue installing Shaft Retainers until all elements are locked in place.

6. Mount the DRIVEN ELEMENT FEED BLOCKS to the boom using a single 8-32 screw 1-1/4" long. Orient with feed and balun connectors as shown on the Dimension Sheet or use OPTIONAL POLARITY SWITCHING driven element. The 'T' block mounts behind the rear driven element.

401CP14 ASSEMBLY MANUAL

7. Thread a 3/8" SEAL-NUT fully onto each connector on the feed block, with black Neoprene side facing out. Generally the balun is installed in one long loop. Attach balun to the block connectors and tighten **gently** using a 7/16" end wrench. Then back the Seal Nuts out and finger-tighten firmly up against the face of the connectors (or tighten **gently** with 1/2" end wrench). Form the balun coax close to the boom and secure with cable ties (snug but not crushing or kinking the coax).
8. Install the 8-32 x 1/4" set screws (internal Allen head - tool supplied) into the SHORTING BARS. Slide the bars onto the 3/16" rod driven element tips and the 1/4" Feed Block Rods. Position the Shorting Bars as specified on the DIMENSION SHEET: the distance given is between the outer face of the Feed Block and the inner face of the Shorting Bar. Align the bars and rods with each other and tighten the sets crews. NOTE: the shorting bar dimensions are different on the OPTIONAL circular switched driven element.
9. Now attach all the cables. The two medium length cables are the 1/2 wave baluns. The long coax cable goes to the the front driven element. And the short cable goes to the rear driven element. Tighten the connectors lightly with a 7/16" end wrench and then run the seal nut up against the face to the connector and tighten no more than one turn past finger tight with a 1/2" end wrench.

REMEMBER CENTER MOUNTED ANTENNA MUST BE PLACE ON A FIBERGLASS OR OTHER STRONG, NON CONDUCTIVE MAST AND THE FEEDLINES MUST RUN OFF THE REAR OF THE ANTENNA. THIS PREVENTS THE CIRCULAR FIELD OF THE ANTENNA FROM BEING DISTORTED BY A METALIC MAST OR METALIC FEEDLINE.

10. For center mounted antennas, the boom to mast plate is normally mounted as close as possible to the balance point (with feedline or a temporary equivalent attached). For rear mounted antennas, use the boom length provided behind the reflector element. Keep mounting plate at least 1" from any element. Secure plate with two U-bolts and the stainless nuts and lock washers provided. DO NOT OVER TIGHTEN. Additional U-bolts and stainless nuts / lockwashers are provided for mounting the antenna to your mast. THIS COMPLETES THE ANTENNA ASSEMBLY.
11. For optimum performance, mount antenna high and in the clear. **Always** use high quality coax and connectors. Old, corroded, or poor quality materials can SERIOUSLY affect VSWR, gain, and pattern. If possible, test the antenna, connectors and feedline BEFORE installation. At 6' in height, the antenna will exhibit performance **approaching** the specifications. If it doesn't, check feedline and connectors for continuity and shorts. Check antenna shorting bars, element placement and length, against Dimension Sheet.
12. MOUNTING AND STACKING INFORMATION

Rear mounted antennas can generally be mounted in any polarization to any type of mast, conductive or non-conductive.

Center mounted antennas can also be mounted in any polarity. **However, a mast or crossboom in-line (parallel) with the element plane must be non-conductive.** Anything conductive in the element plane will disrupt the pattern and reduce performance (even the feedline). When a non-conductive mast or crossboom is in-line with elements, route feedline away at right angles to the elements and reattach at least 6" beyond element tips. Fiberglass is the recommended material for a non-conductive mast or crossboom because of it's strength and weather resistance.

Stacking: See the Dimension Sheet for stacking separation dimensions.

 1. All driven element blocks MUST be oriented to the same side of boom.
 2. All boom-to-mast plates MUST be mounted at the same point on the boom.
 3. Feed / phasing lines MUST be of equal electrical length or, ideally, multiples of 1 wavelength in order to maintain equal phasing in the array.

M² ANTENNA SYSTEMS, INC.
4402 N. Selland AVE.
FRESNO, CA 93722
(559) 432-8873 FAX: 432-3059

401CP14 DIMENSION SHEET

401CP14 DIMENSION SHEET

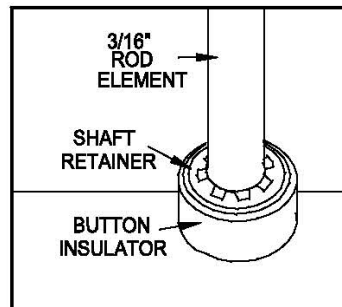
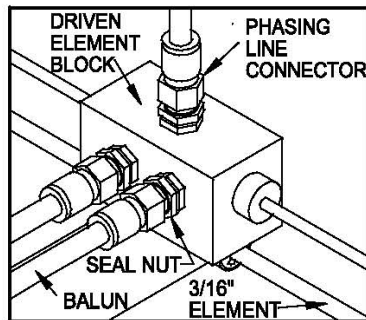
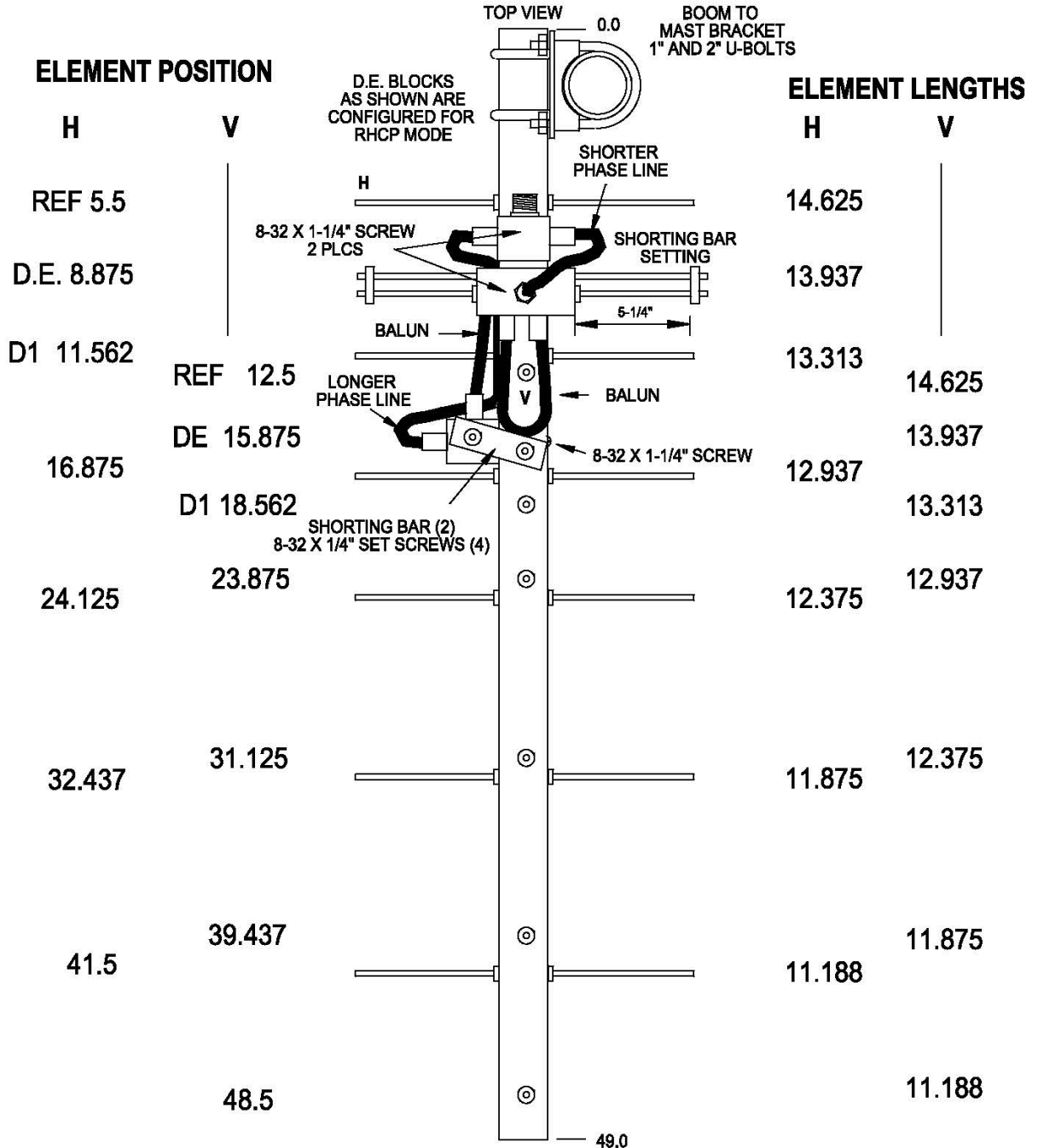

401CP14D
K GRIFFITH
6-8-00
REV. 6-12-00

401CP14 PARTS & HARDWARE

DESCRIPTION.....	QTY
BOOM SECTION #1, 1.0 X .058 X 49.00".....	1
BOOM-TO-MAST PLATE, 3 X 4 X 1/8"(M2APT0019)....	1
ELEMENT SET , 3/16" X SEE DIM" SHEET	14
DRIVEN ELEMENT ASSEMBLY,	2
JUNCTION BLOCK ASSEMBLY (SADE0060).....	1
BALUN CABLE , 1/2 WAVE RG-6U	2
PHSASE LINE, LONG, 3/4 WAVE RG-6U	1
PHASE LING, SHORT, 1/4 WAVE RG-6U.....	1
U-BOLT AND CRADLE, 2"	2
U-BOLT, 1-1/2"	2
U-BOLT 1" , NO CRADLE.....	2
ASSEMBLY MANUAL.....	1

IN HARDWARE BAG:

SHORTING BAR, 1/8 AND 3/16 HOLES.....	4
BUTTON INSULATORS	28
SHAFT RETAINER, (KEEPER) SS	28
NUT, 5/16-18 SS.....	4
LOCKWASHER, 5/16 SS.....	4
NUT, 1/4-20, SS.....	4
LOCK WASHER, 1/4" SPLIT RING , SS	4
SCREW, 8-32 X 1-1/4 SS	3
SET SCREW, 8-32 X 1/4, SS	8
SEAL NUTS, 3/8-32.....	8
CABLE TIE, NYLON	4
ALLEN HEAD WRENCH, 5/64"	1
PUSH TUBE, 3/8 X 3"	1

M² ANTENNA SYSTEMS, INC.

4402 N. SELLAND AVE.

FRESNO, CA 93722

(559) 432-8873 FAX: 432-3059

www.m2inc.com Email: sales@m2inc.com