

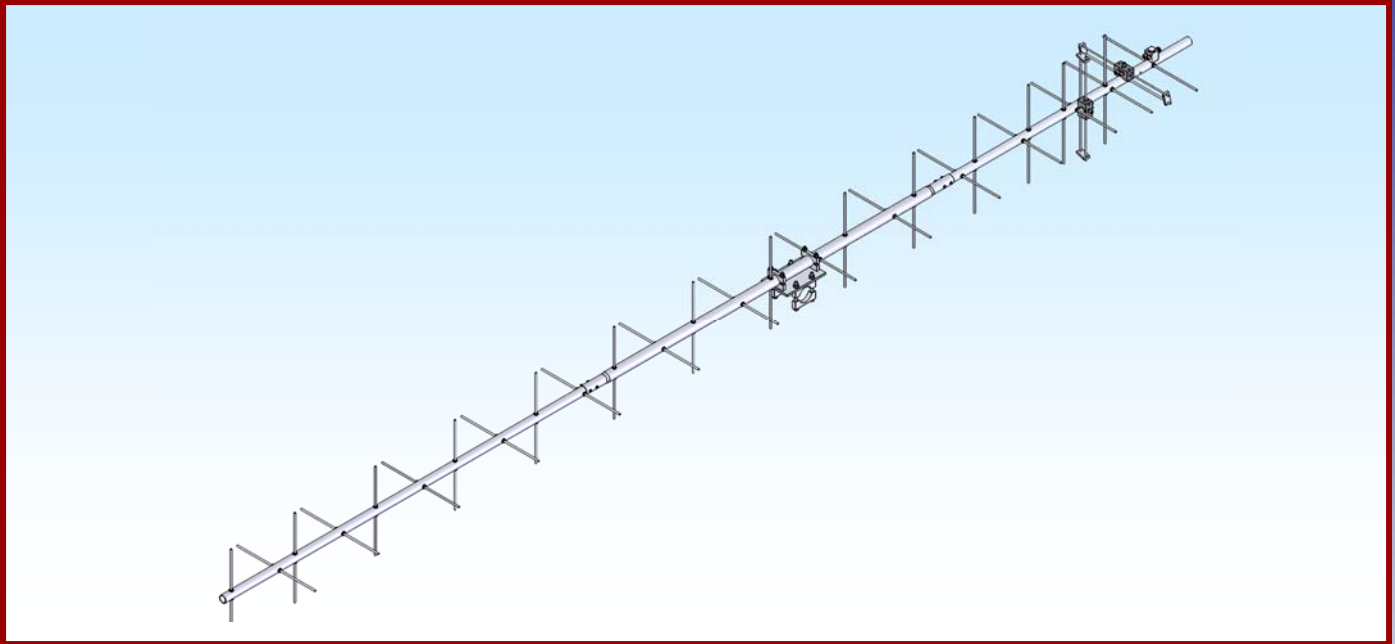

M2 Antenna Systems, Inc. Model No: 406CP30



SPECIFICATIONS:

Model	406CP30	Power Handling	1.5 kW
Frequency Range.....	403 To 409 mHz	Boom Length / Dia.....	150" / 1" & 1-1/4"
*Gain	16.9 dBi	Maximum Element Length.....	14.5"
Front to back	23 dB Typical	Turning Radius:	90"
Feed type	Folded Dipole	Stacking Distance.....	52"
Feed Impedance.	50 Ohms Unbalanced	Mast Size.....	2" Nom.
Maximum VSWR.....	1.5:1	Wind area / Survival	1.0 Sq. Ft. / 100MPH
Input Connector.....	"N" Female	Weight / Ship Wt.....	6 Lbs. / 10 Lbs.

***Subtract 2.14 from dBi for dBd**

FEATURES:

The 406CP30 is high performance circular polarized antenna with a remarkably clean pattern. The pattern is important in order to match the antenna's noise temperature with modern low noise preamps. This antenna is ideal for satellite work but is also excellent for terrestrial uses like long haul tropo communications.

The CNC machined driven element module is O-ring sealed and weather tight for low maintenance and long-term peak performance. Internal connected are encapsulated in a space-age silicone gel that seals out moisture and improves power handling. The 3/16" 6061-T6 rod elements are centered on the boom to minimize interaction and maintain good ellipticity. Insulators are UV stabilized and locked in place with stainless keepers. Rugged construction, uncompromising performance for the boom length: that's the M² 406CP30!

406CP30 ASSEMBLY MANUAL

TOOL REQUIRED FOR ASSEMBLY: screwdriver, 11/32 nut driver or wrench, 7/16" and 1/2" socket or end wrenches, measuring tape.

1. Assemble the boom using 8-32 screws and locknuts to join sections. (SEE BOOM LAYOUT PAGE).

ASSEMBLING THE HORIZONTAL ELEMENTS

2. Lay out the elements by "Horizontal" length and position as shown the DIMENSION SHEET. Start with the reflector (longest) element. Balance it on your finger to find rough center and push on a black button insulator to about 1/2" off center. Push the element through the hole on the boom and install the second button, snugging it up into boom. **DO NOT BOTHER CENTERING** the element at this time and **DO NOT INSTALL** the stainless steel shaft retainers yet. It is easier to do it after all the horizontal elements are installed in the boom.
3. Install the 3/16" rod DRIVEN ELEMENT as you did the reflector. Then continue with the installation of the DIRECTORS. **Note: the Director Elements do not consistently diminish in length from rear to front, so pay close attention to length and position.**
4. Now begin centering the elements. Use a tape measure to EQUALIZE the amount the element sticking out on each side of the boom. Once you have all the elements centered, sight down the element tips from the rear comparing each side. Look for any obvious discrepancies and correct if found.
5. Stainless steel SHAFT RETAINERS lock the elements in place. They should always be used for permanent and long term antenna installations. For portable or temporary use, the button insulators are adequate for holding the elements and the retainers may be left off.
To install the stainless steel SHAFT RETAINERS, use thumb and forefinger to hold the retainer over the end of the PUSH TUBE (3/8" x 3" tube, supplied in the kit), internal fingers on retainer dished into tube. **HOLD THE ELEMENT FIRMLY TO PREVENT IT FROM SLIDING OFF CENTER** and press the retainer onto the element end and continue until retainer butts on insulator button. Locking pliers, **lightly** clamped up against opposite button insulator will help maintain center reference (if you push the first retainer too far, remove element from boom, push retainer completely off the element, and start over). Install another retainer to the opposite side of the element. Continue installing retainers until all elements are secured.

6. Mount the **HORIZONTAL DRIVEN ELEMENT ROD ASSEMBLY** to the **TOP** of the boom using a single 8-32 X 1-1/4" screw (SEE PICTURE).
7. Install the 8-32 x 1/4" set screws (internal Allen head - tool supplied) into the SHORTING BARS. Slide the bars onto the Driven Element Block Rods and the 3/16" driven element rods. **Position the Shorting Bars as shown on dimension sheet.**

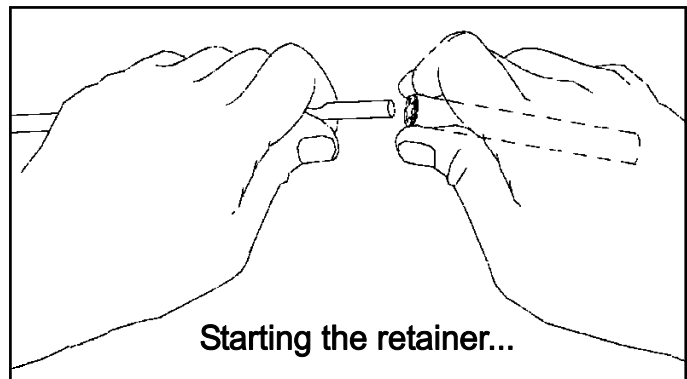

ASSEMBLING THE VERTICAL ELEMENTS

Note: The vertical element set is shifted forward on the boom by 1/4 wave lengths. This increases isolation between element planes, improving circularity and ease of phasing / matching the two element sets.

8. Repeat steps #2 through #5 for the Vertical elements, using the Dimension Sheet as your guide to lengths and spacing.

INSTALLATION OF THE VERTICAL DRIVEN ELEMENT BLOCK DETERMINES THE CIRCULARITY OF THIS ANTENNA. THE ORIENTATION OF THE BLOCK FOR RHC - RIGHT HAND CIRCULARITY, IS SHOWN ON THE DIMENSION SHEET.

9. Viewed from the rear of the boom (rearmost Reflector HORIZONTAL), the VERTICAL Driven Element Block mounts to the LEFT hand side of the boom with the two Balun connectors oriented to the REAR. Secure with 8-32 x 1-1/4" screw. Install the Shorting Bars as in step #7.

406CP30 ASSEMBLY MANUAL

10. Before installing the Baluns and Matching / Phasing Harness, thread 3/8" SEAL NUTS fully onto all connectors, with the black Neoprene face of the nuts facing out. Attach Baluns and Phasing lines to the Driven Element Blocks and Junction Block as shown on the picture below. Tighten the connectors **gently** using a 7/16" end wrench. Once the connectors are tight, back the Seal Nuts out and finger-tighten firmly up against the face of the connectors (or tighten **gently** with 1/2" end wrench). A lot of torque is unnecessary. Depending on model and polarity, the Vertical balun may loop around another element. This is normal. Form balun coax until it is close to the boom and secure with a nylon cable tie. Also secure the other balun and the matching / phasing harness coax with cable ties. Ties should be snug but not crushing or kinking the coax.
11. Use good quality coax and "N" connector for your feedline (see Installation Tips). Secure feed coax near connector on Junction Block, to provide stress relief. Allow about 60" of coax to hang in a loop between the rear end of the boom and the reattachment point (at least 12" beyond element tips) on the mast or crossboom. **Do not route feedline thru boom to mast plate as exiting antenna here will adversely affect circular field.**
12. The boom to mast plate is normally mounted to the boom at the balance point. Since the feed line represents significant weight it is best to have it attached and fastened to the boom with cable ties before final mounting the plate. Use two 1" U-bolts and the stainless nuts and lock washers provided. DO NOT OVER TIGHTEN. 2" U-bolts (and stainless steel nuts / lockwashers) are provided for mounting the antenna to your NON-CONDUCTIVE mast or crossboom. Other size u-bolts and cradles are available upon request.

THIS COMPLETES THE ANTENNA ASSEMBLY.

INSTALLATION TIPS

1. The 406CP30 is a circular polarized antenna and creates a field in all planes or polarities. Performance DETERIORATES SIGNIFICANTLY if it is mounted on a metal (conductive) mast or crossboom. A mast or crossboom of any NON-CONDUCTIVE material must be used. Fiberglass is the prime choice for its strength and weather resistance. Mount the antenna so that element tips are at least 12" from any conductive material (mast, tower, feedline, etc.).
2. Recommended feedlines, in order of preference:
Andrews or Celwave 1/2" hardline
Times LMR-400 or Belden 8214
Try to keep the cable run to under 100 ft. to prevent excessive signal loss.
3. To maintain proper phasing when stacking two or more antennas, mount each with the same orientation of Driven Element Blocks. DO NOT MOUNT IN MIRROR IMAGE. See the Specification Sheet for stacking distances. For more detailed stacking information contact M².

M² ANTENNA SYSTEMS, INC.

4402 N. SELLAND AVE.

FRESNO, CA 93722

(559) 432-8873 FAX: 432-3059

www.m2inc.com Email: sales@m2inc.com

406CP30 BOOM LAYOUT

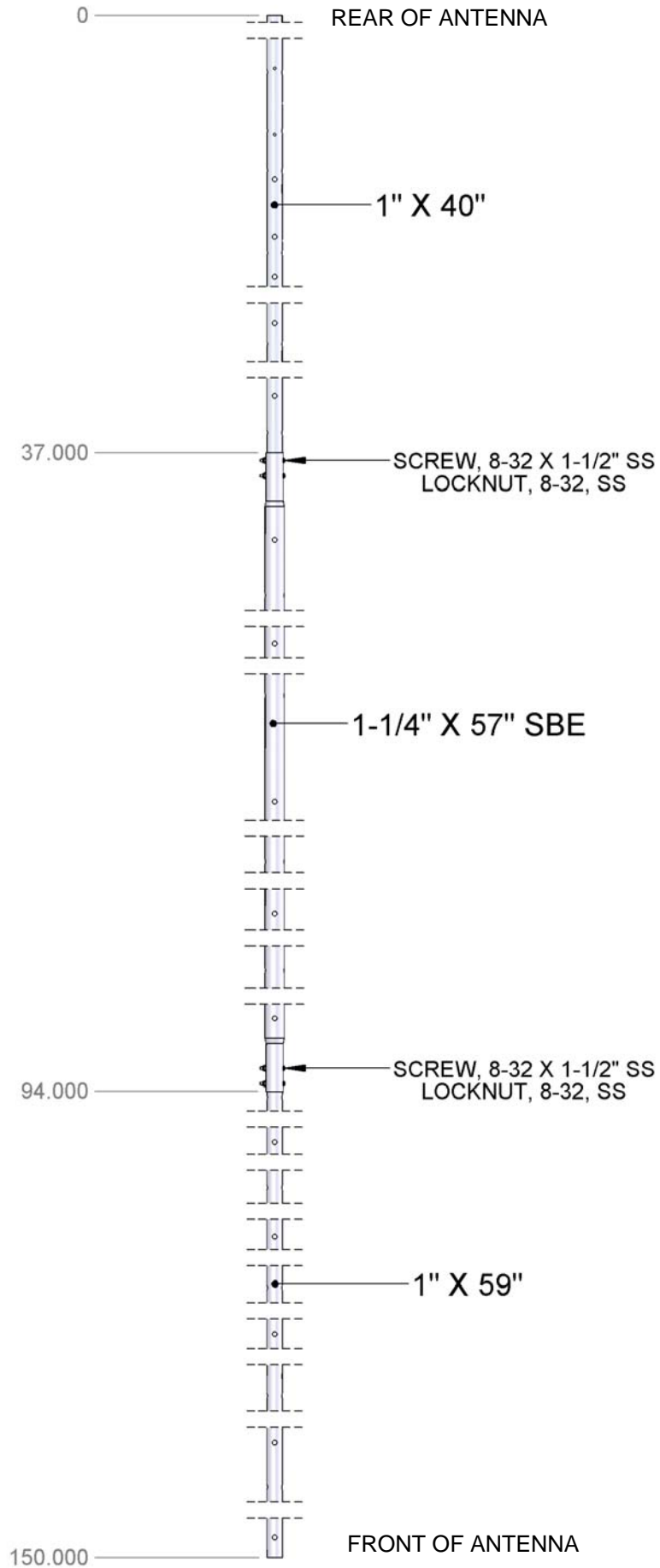

406CP30 DIMENSION SHEET

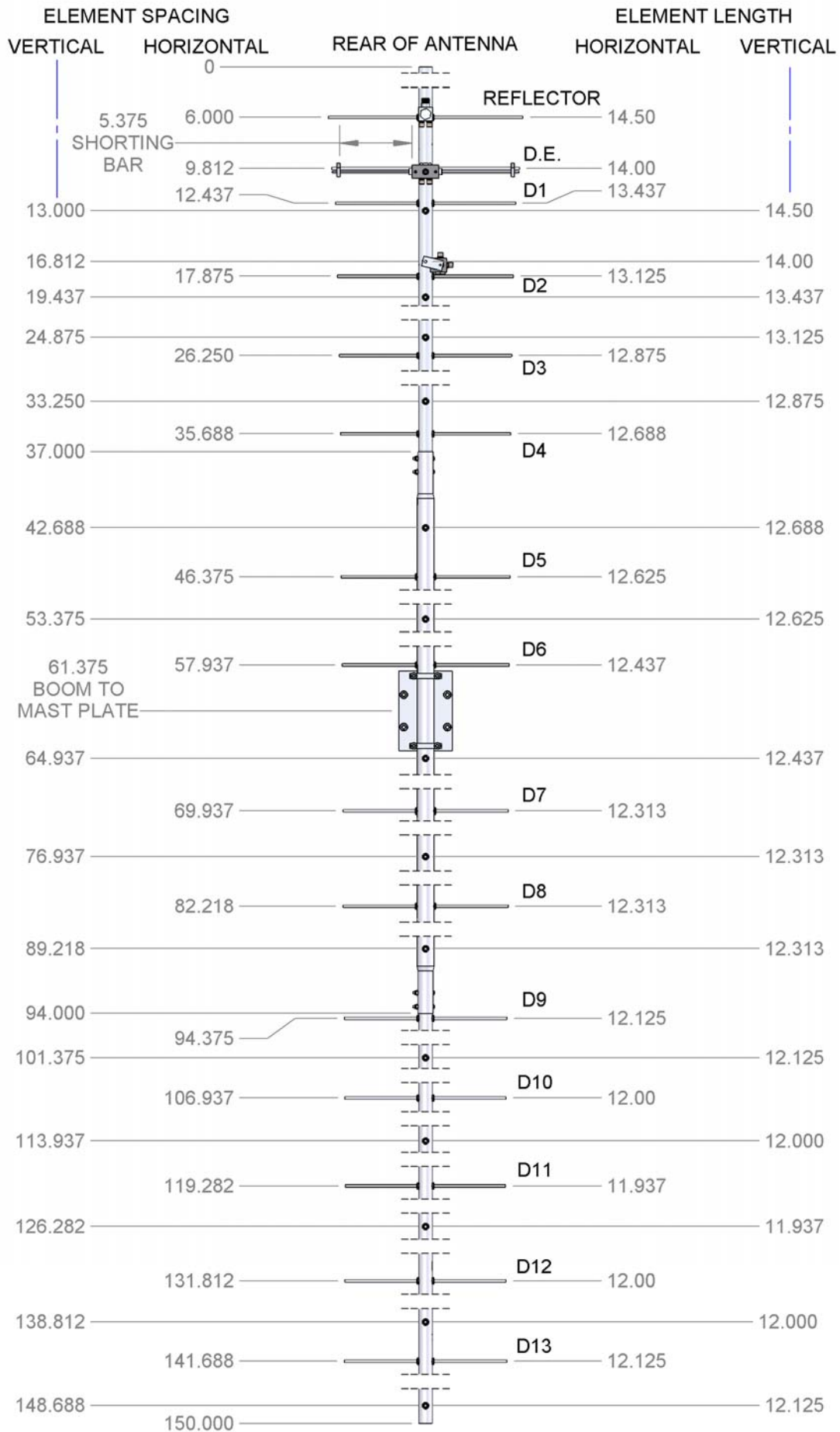

406CP30 BOOM TO MAST DETAIL

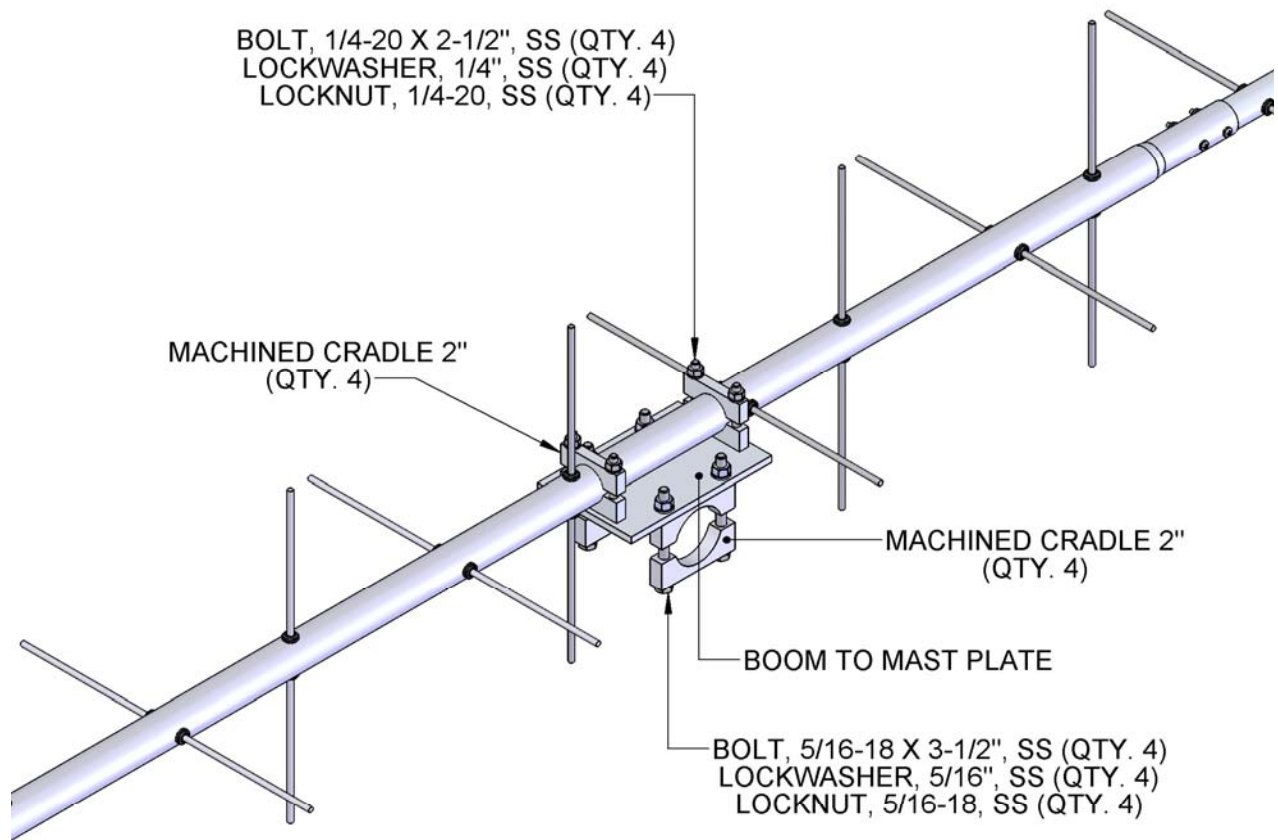

406CP30 D.E./BALUN/PHASE LINE DETAIL

REAR OF ANTENNA

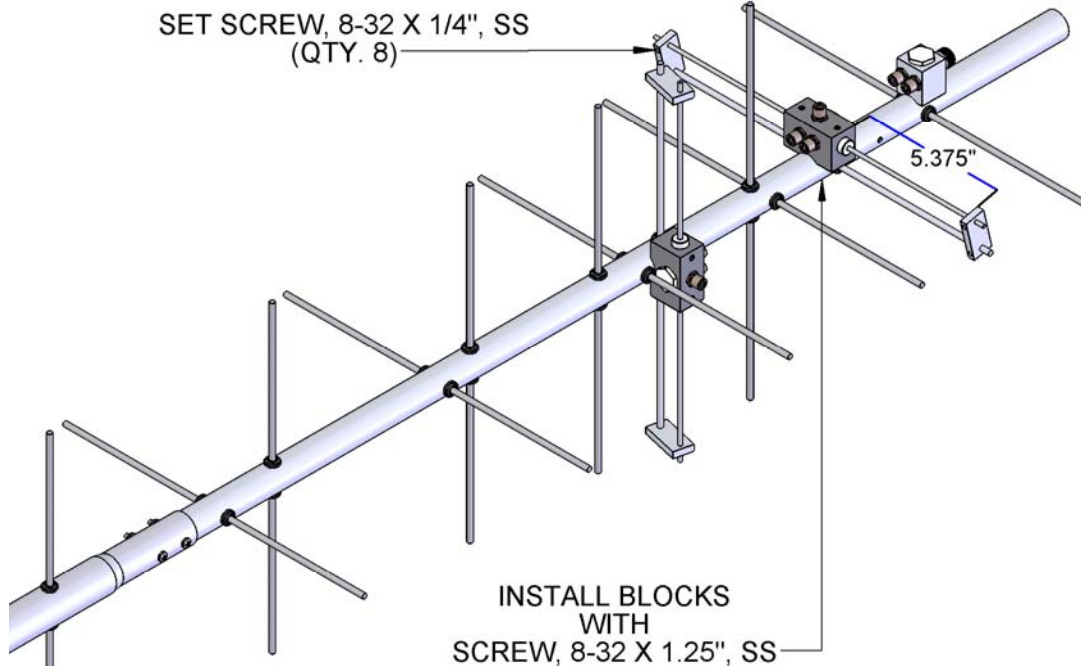

NOTE:

INSTALLATION OF THE D.E. BLOCKS DETERMINES THE CIRCULARITY OF THIS ANTENNA. THE ORIENTATION OF THE BLOCKS FOR RHC - RIGHT HAND CIRCULARITY, IS SHOWN ABOVE, BELOW & ON THE DIMENSION SHEET.

FOR LHC - LEFT HAND CIRCULARITY, SIMPLY REVERSE ONLY ONE OF TWO D.E. BLOCKS TO THE OPPOSITE SIDE OF THE BOOM. DO NOT TO REVERSE THE DIRECTIONS OF THE BALUNS.

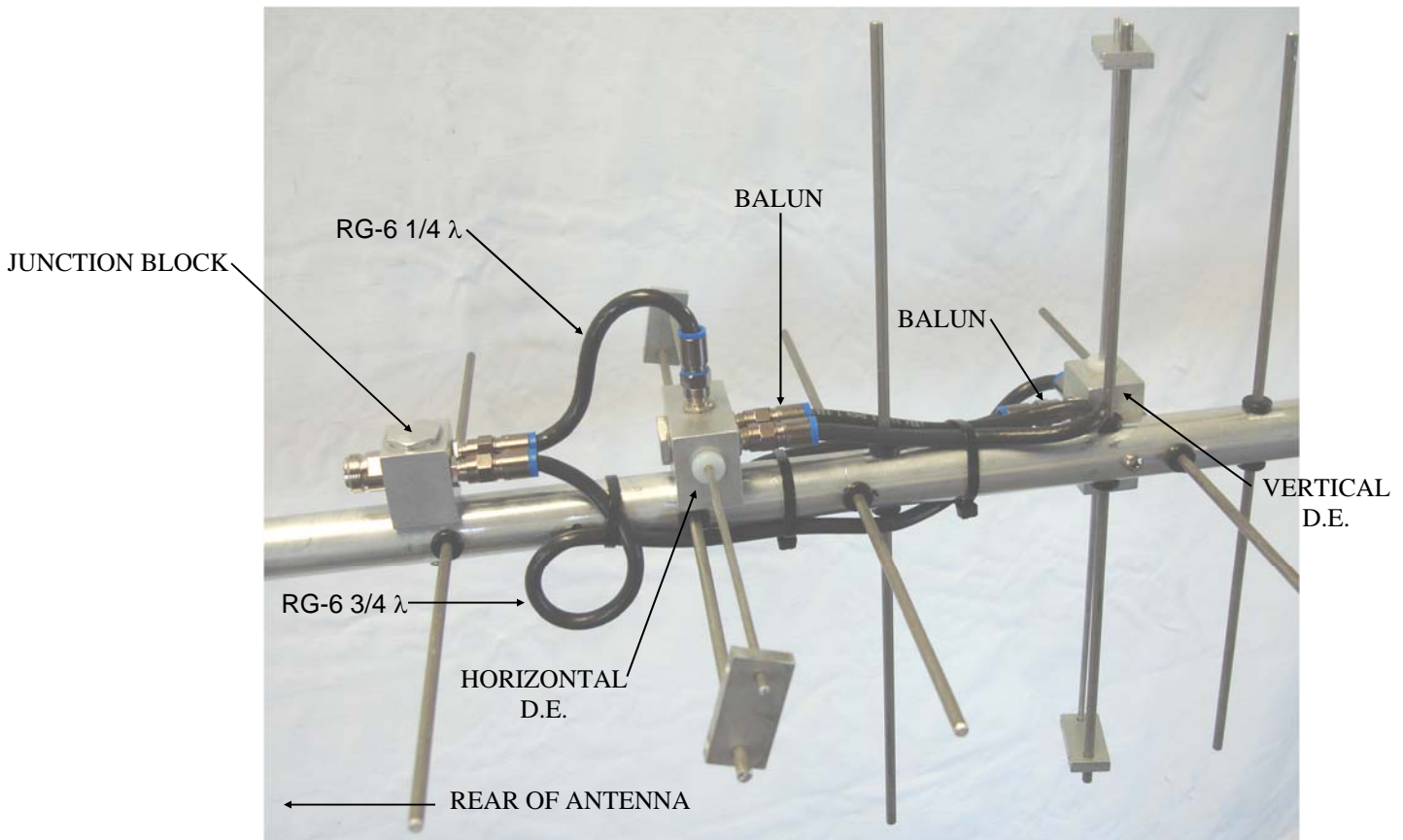

406CP30 PARTS & HARDWARE

DESCRIPTION	QTY
BOOM SECTION # 1, 1.0 X .058 X 40"	1
BOOM SECTION # 2, 1.25 X .058 X 57" SBE	1
BOOM SECTION # 3, 1.0 X .058 X 59"	1
ELEMENTS, 3/16 ROD x DIM SHEET	30
DRIVEN ELEMENT ASSEMBLY	2
"NEW" JUNCTION BLOCK ASSEMBLY	1
BALUN RG-6 X 14"	2
PHASE LINE, RG-6 1/4 λ (7")	1
PHASE LINE, RG-6 3/4 λ (19.50")	1
BOOM-TO-MAST PLATE, 4 X 6 X .250"	1
SHORTING BAR, 1/4" X 3/4" (M2ASB0080)	4
M-CRADLE, 2" (M2AMC0130)	4
M-CRADLE, 1.25"	4
PENETROX / ZINC PASTE CUP	1
ASSEMBLY MANUAL	1

HARDWARE:

BUTTON INSULATORS	64
SHAFT RETAINER, SS	64
BOLT, 5/16-18 X 3-1/2 SS	4
NUT, 5/16-18 SS	4
LOCKWASHER, 5/16 SS	4
BOLT, 1/4-20 X 2-1/2 SS	4
NUT, 1/4-20 SS	4
LOCKWASHER, 1/4 SS	4
SCREW, 8-32 X 1-1/2 SS	4
SCREW, 8-32 X 1-1/4 SS	3
LOCKNUT, 8-32 SS	4
SETSCREW, 8-32 X 1/4, SS	8
CABLE TIE, 8" NYLON	4
SEAL NUTS, 3/8-32	8
ALLEN HEAD WRENCH, 5/64"	1
PUSH TUBE, 3/8 X 3"	1

M² ANTENNA SYSTEMS, INC.

4402 N. SELLAND AVE.

FRESNO, CA 93722

(559) 432-8873 FAX: 432-3059

www.m2inc.com Email: sales@m2inc.com