

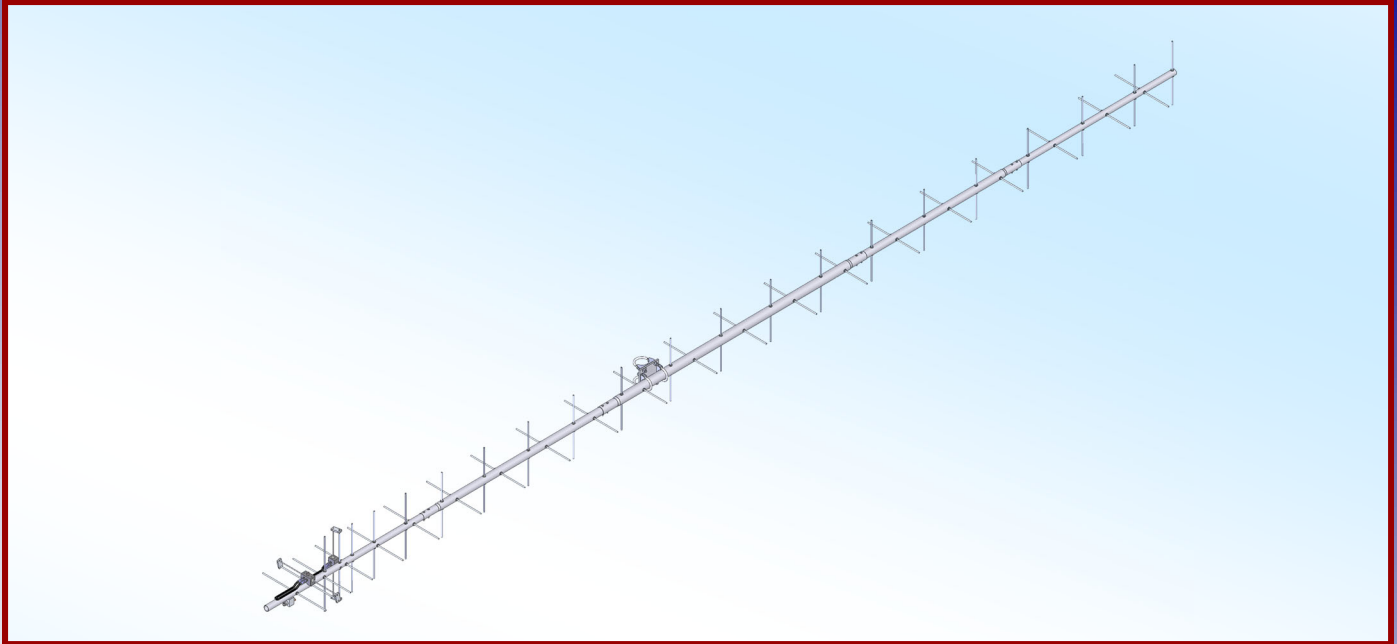

M2 Antenna Systems, Inc. Model No: 430CP44



SPECIFICATIONS:

Model	430CP44	Power Handling	1.5 kW
Frequency Range.....	420 To 440 MHz	Boom Length / Dia.....	225" / 1-1/2" - 1"
*Gain	18.72 dBic	Maximum Element Length.....	15"
Front to back	18 dB Typical	Turning Radius:	Call
Feed type	"T" Match	Stacking Distance.....	Call
Feed Impedance.....	50 Ohms Unbalanced	Mast Size.....	1-1/2" to 2" Nom.
Maximum VSWR.....	1.5:1 Typical	Wind area / Survival	1.5 Sq. Ft. / 100MPH
Input Connector.....	"N" Female	Weight / Ship Wt.....	9 Lbs. / 12 Lbs.

***Subtract 2.14 from dBi for dBd**

FEATURES:

The 430CP44 is high performance circular polarized antenna with a remarkably clean pattern. The pattern is important in order to match the antenna's noise temperature with modern low noise preamps. This antenna is ideal for satellite work but is also excellent for terrestrial uses.

The CNC machined driven element module is O-ring sealed and weather tight for low maintenance and long-term peak performance. Internal connected are encapsulated in a space-age silicone gel that seals out moisture and improves power handling. The 3/16" 6061-T6 rod elements are centered to minimize interaction and maintain good ellipticity. Insulators are UV stabilized and locked in place with stainless keepers. Rugged construction, uncompromising performance for the boom length.

430CP44 ASSEMBLY MANUAL

TOOLS REQUIRED FOR ASSEMBLY: Phillips head screwdriver, 11/32" nut driver, 7/16" and 1/2" end wrench and measuring tape.

BOOM ASSEMBLY

1. Refer to Dimension Sheet the proper orientation for the four boom sections. Secure per the DIMENSION SHEET with the supplied 8-32 screws and locknuts. Next attach the "L"-Bracket to the 1-1/4" boom section as shown on the dimension sheet with the supplied 8/32 x 1-3/4" screws and locknuts. It may be helpful to support the boom up on a small mast or pole to aid in the rest of the assembly. Add the four cradles and 5/16" hardware to the "L"-Bracket as shown in the figure below and secure the entire boom assembly to a convenient working height.

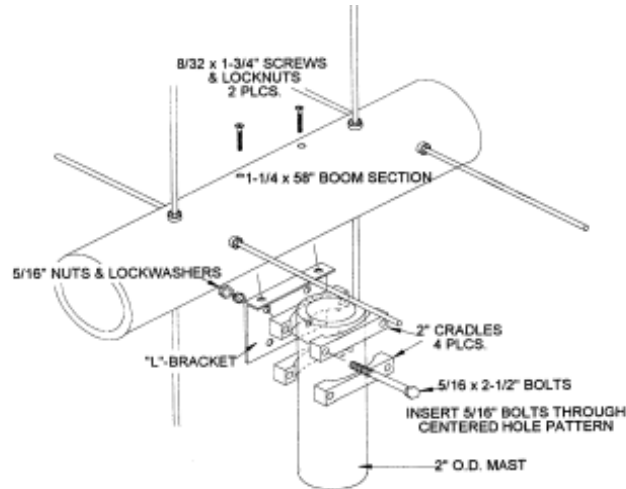

ASSEMBLING THE HORIZONTAL ELEMENTS

2. NOTE: SOME HORIZONTAL LENGTHS DIFFER FROM THE VERTICAL LENGTHS

Separate the 3/16" ROD ELEMENTS by length into their appropriate horizontal and vertical sets. A convenient way of installing the elements is to lay the element sets in order from reflector to director on a flat surface. Starting with the horizontal REFLECTOR (longest) element, balance it on your finger to find the center and push on a black button insulator to 1/2 the boom diameter off center. Slide the element through the holes near the rear of the boom and install the second button, snugging it up into boom. Don't accurately center the element or install the stainless steel shaft retainers yet. It is easier to do it after all the horizontal elements are installed in the boom.

RHC AS VIEWED FROM UNDERNEATH REVERSE MOUNTING SIDE OF FRONT BLOCK FOR LHC

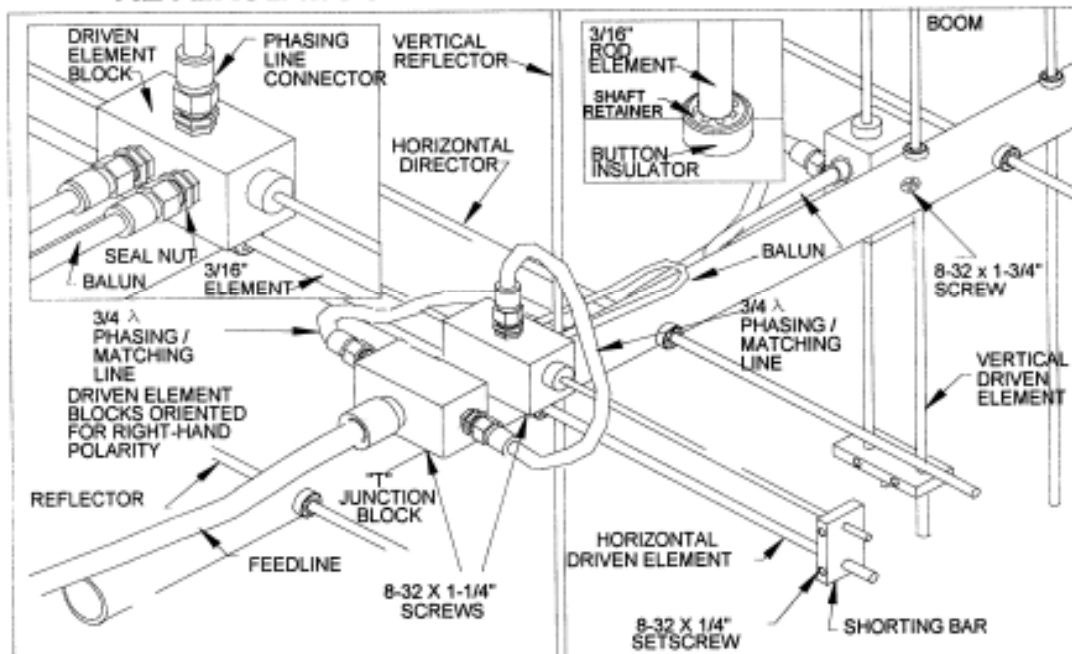

430CP44 DIMENSION SHEET

430CP44 DIMENSION SHEET

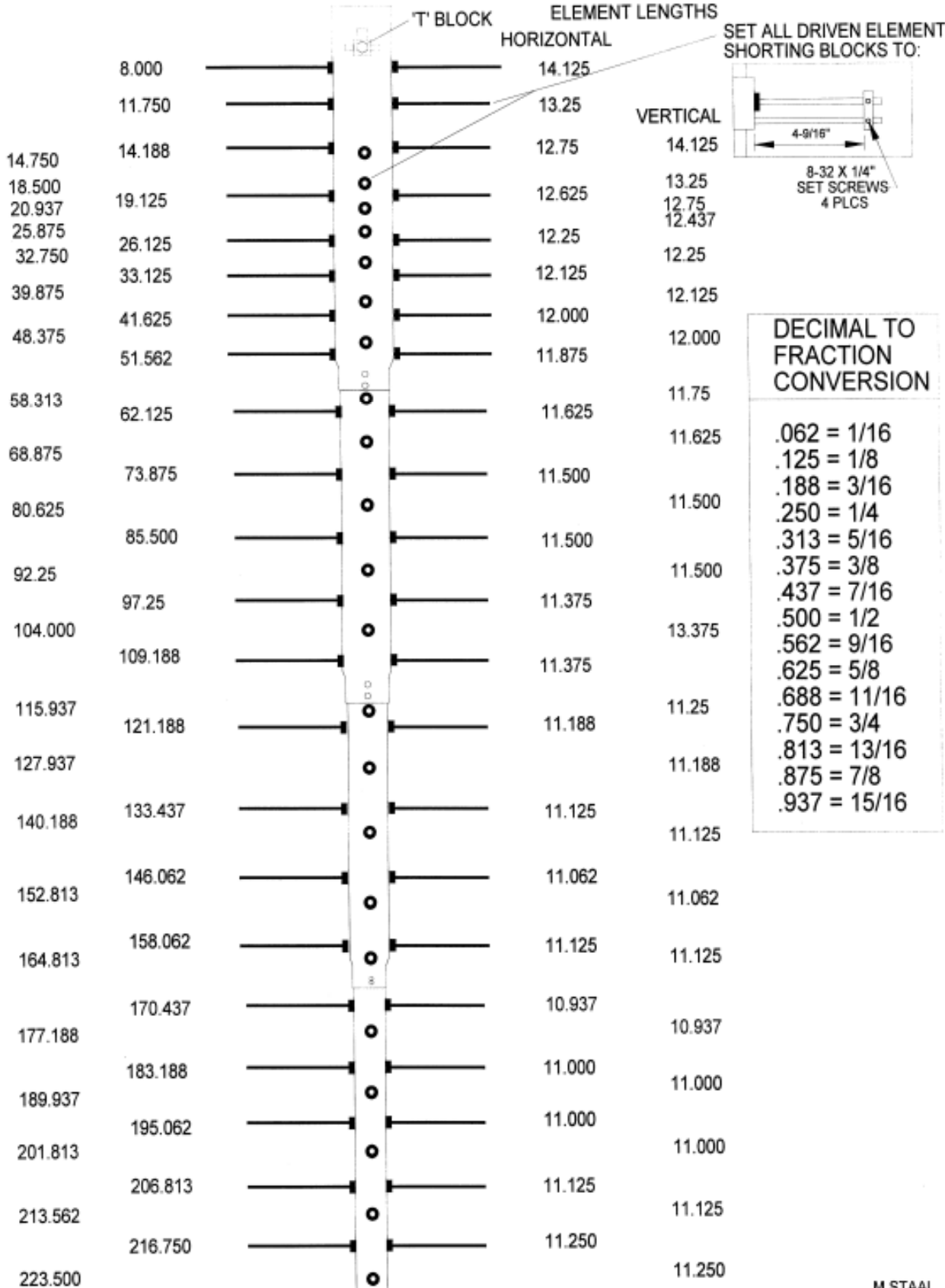

DECIMAL TO FRACTION CONVERSION

.062	= 1/16
.125	= 1/8
.188	= 3/16
.250	= 1/4
.313	= 5/16
.375	= 3/8
.437	= 7/16
.500	= 1/2
.562	= 9/16
.625	= 5/8
.688	= 11/16
.750	= 3/4
.813	= 13/16
.875	= 7/8
.937	= 15/16

430CP44 ASSEMBLY MANUAL

3. Continue with the installation of the DIRECTORS. Note that the Director Elements do not consistently diminish in length from rear to front, so pay close attention to length and position. The DRIVEN ELEMENT BLOCK is mounted in step #6.

4. Now begin centering the elements. Use a tape measure to EQUALIZE the amount the element sticking out on each side of the boom. Once you have all the elements centered, sight down the element tips from the rear comparing each side. Look for any obvious discrepancies and correct if found.

5. Begin installing the stainless steel SHAFT RETAINERS. Use thumb and index finger to hold a retainer over end of the 3/8" x 3" push tube (retainer dished into tube). Hold the element firmly and start the retainer onto the rod by applying pressure with the push tube. Push the retainer until up tight against the button insulator (locking pliers, lightly clamped up against opposite button insulator will help maintain center reference and keep you from pushing the first retainer too far, or grasp the opposite side of the element and pull it hard sideways to the boom to preload and increase the friction of the element on the button insulators while pushing the retainer.) Repeat for the opposite side. Continue installing retainers until all elements are locked in place.

6. Mount the HORIZONTAL DRIVEN ELEMENT ASSEMBLY to the **BOTTOM** of the boom using a single 8/32 x 1-3/4" screw. Orient the block with the two balun "F" connectors facing towards the front.

ASSEMBLING THE VERTICAL ELEMENTS

7. Repeat steps #1 through #5 for the Vertical elements, using the Dimension Sheet as your guide to lengths and spacings.

8. The orientation of the VERTICAL DRIVEN ELEMENT BLOCK determines the CIRCULARITY (RHC, Right Hand Circularity, or LHC, Left Hand Circularity) of the antenna. FOR RHC: Viewed from the rear of the boom and underneath (rearmost Reflector HORIZONTAL), the VERTICAL Driven Element Block mounts to the LEFT hand side of the boom (see assembly drawing). For LHC install block to RIGHT hand side of boom. Secure with 8/32x 1-1/4" screw.

9. Install the "T" JUNCTION BLOCK TO THE 8/32" hole near rear end of the boom with a 8/32 x 1-3/4" screw. Before installing the Matching / Phasing Sections, thread 3/8" seal nuts fully onto all "F" connectors, with the black Neoprene face of the nuts facing out. Attach Matching / Phasing lines to the Driven Element Blocks and Junction Block as shown on the drawing. Tighten the connectors gently using a 7/16" end wrench. Once the connectors are tight, back the seal nuts out and finger-tighten firmly up against the face of the connectors and tighten gently with 1/2" end wrench. A lot of torque is unnecessary. Form phasing lines close to the boom and secure with a nylon cable tie. Ties should be snug but not crushing or kinking the coax.

10. Use good quality coax and "N" connector for your feedline (see installation tips). Secure feed coax near connector on Junction Block, to provide stress relief. Do not route feedline to boom "L"-Bracket plate as it will adversely affect the circular field. Route feedline off the rear of the boom.

INSTALLATION TIPS

11. the 430CP44 is a circular polarized antenna and creates a field in all planes or polarities. Performance DETERIORATES SIGNIFICANTLY if it is mounted on a metal (conductive) mast or crossboom. A mast or crossboom of any NON-CONDUCTIVE material can be used. Fiberglass is the prime choice for its strength and weather resistance. Mount the 430CP44 so that element tips are at least 12" from any conductive material (mast, tower, feedline, etc.).

12. Try to keep the cable run to under 100 ft. to prevent excessive signal loss, unless a good, low noise preamp will be used.

13. To maintain proper phasing when stacking two or more antennas, mount each with the same orientation of Driven Element Blocks. DO NOT MOUNT IN MIRROR IMAGE.

CAREFULLY MANUFACTURED BY:
M2 Antenna Systems, Inc.
4402 N. Selland Ave.
Fresno, CA 93722
(559) 432-8873 Fax (559) 432-3059
www.m2inc.com email: sales@m2inc.com

430CP44 PARTS & HARDWARE

DESCRIPTION	QTY
BOOM SECTION, 1-1/2 X .058 X 57" SOE	1
BOOM SECTION, 1-1/4 X .058 X 60" SOE	1
BOOM SECTION, 1 X .058 X 58" SOE	1
BOOM SECTION, 3/4 X .049 X 58"	1
ELEMENTS, 3/16 ALUM ROD (SEE DIMENSION SHEET)	44
DRIVEN ELEMENT BLOCK ASSY	2
JUNCTION BLOCK.....	1
BALUN, RG-6 (1/2 WAVE)	2
PHASIN LINE, RG-6 (3/4 WAVE).....	2
BRACKET, "L" MOUNTING PLATE 3-1/4 X 4 SPECIAL	1
CRADLES, 2" UNIVERSAL	4
CLAMP BLOCK, 3/8"	3
CLAMP PLATE, 3/8"	1
FIBERGLASS ROD, 3/8" X 14"	1
ASSEMBLY MANUAL	1

IN HARDWARE BAG:

SHORTING BARS, 1/4 X 3/4 X 1.875	4
BUTTON INSULATORS, 3/16"	88
SHAFT RETAINER, 3/16" SS	88
SCREW, 8-32 X 1" SS	4
SCREW, 8-32 X 1-1/4" SS	2
SCREW, 8-32 X 1-1/2" SS.....	2
SCREW, 8-32 X 1-3/4" SS.....	5
SCREW, 8-32 X 2" SS	2
LOCKNUT, 8/32.....	12
SET SCREW, 8/32 X 1/4" SS	8
EYEBOLT, 1/4 X 2" SS.....	2
TURNBUCKLE, 1/4" SS	2
DACRON ROPE, 3/16" X 15"	1
BOLT, 5/16-18 X 3.5" SS.....	4
LOCKWASHER, 5/16" SS	4
NUT, 5/16" SS.....	4
NUT SEALS	8
CABLE TIE, NYLON	3
PUSH TUBE, 3/8" X 3"	1
ALLEN WRENCH, 5/64"	1

M² ANTENNA SYSTEMS, INC.

4402 N. SELLAND AVE.

FRESNO, CA 93722

(559) 432-8873 FAX: 432-3059

www.m2inc.com Email: sales@m2inc.com