

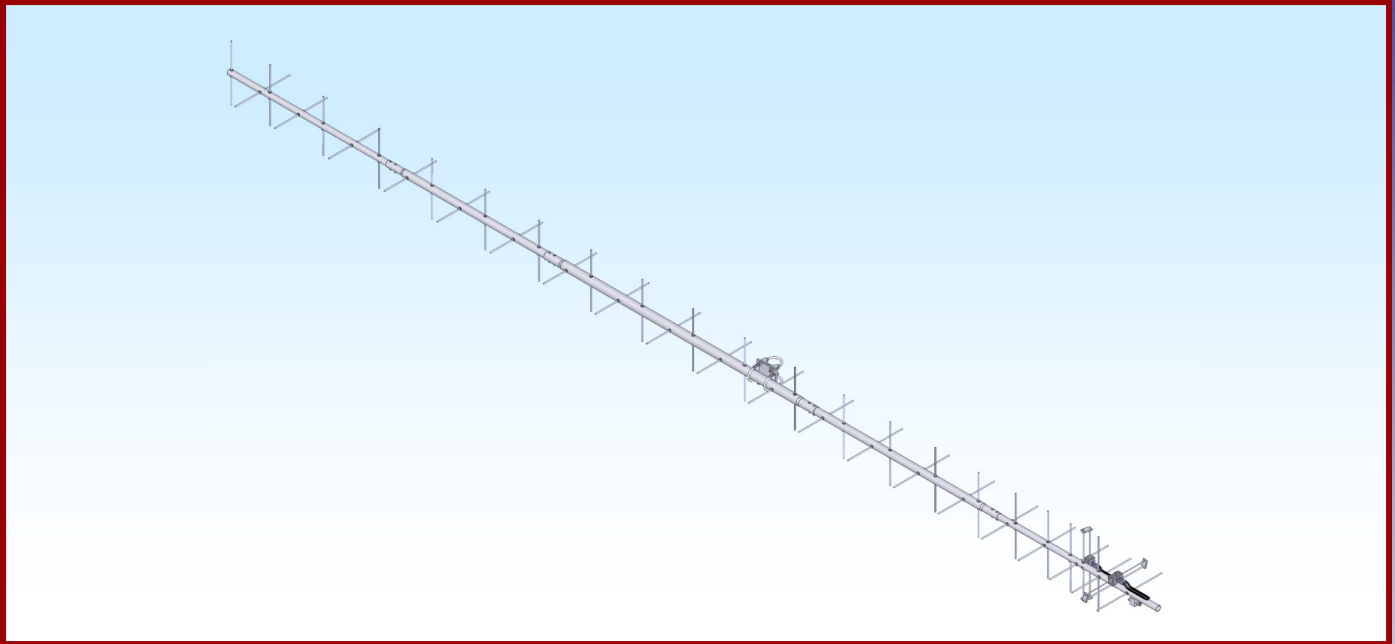

M2 Antenna Systems, Inc. Model No: 450CP42



SPECIFICATIONS:

Model	450CP42	Power Handling	1.5 kW
Frequency Range.....	435 To 455 mHz	Boom Length / Dia.....	193" / 1", 1-1/4" & 1-1/2"
*Gain	18.0 dBi	Maximum Element Length.....	13-1/2"
Front to back	23 dB Typical	Turning Radius:	111"
Beamwidth	24° Circular	Stacking Distance.....	60" High / 60" Wide
Feed type	Folded Dipole	Mast Size.....	1-1/2" to 2" Nom.
Feed Impedance.	50 Ohms Unbalanced	Wind area / Survival	1.5 Sq. Ft. / 100MPH
Maximum VSWR.....	1.2:1	Weight / Ship Wt.....	9 Lbs. / 12 Lbs.
Input Connector.....	"N" Female		

***Subtract 2.14 from dBi for dBd**

FEATURES:

The 450CP42 is high performance circular polarized antenna with a remarkably clean pattern. The pattern is important in order to match the antenna's noise temperature with modern low noise preamps. This antenna is ideal for satellite work but is also excellent for terrestrial uses like ATV, repeater operation, and long haul tropo DX.

The CNC machined driven element module is O-ring sealed and weather tight for low maintenance and long-term peak performance. Internal connected are encapsulated in a space-age silicone gel that seals out moisture and improves power handling. The 3/16" 6061-T6 rod elements are centered to minimize interaction and maintain good ellipticity. Insulators are UV stabilized and locked in place with stainless keepers. Rugged construction, uncompromising performance for the boom length: that's the M² 450CP42!

450CP42 ASSEMBLY MANUAL

TOOL REQUIRED FOR ASSEMBLY: screwdriver, 11/32 nut driver or wrench, 7/16" and 1/2" socket or end wrenches, measuring tape.

1. Assemble the boom using 8-32 screws and locknuts to join sections. (See Dimension Sheet).

Note: If mounting antenna to a standard H-frame with a T-brace kit, it is important to install the T-brace coupling bars to antenna before elements. Refer to H-Frame and T-brace drawings for placement and more information.

ASSEMBLING THE HORIZONTAL ELEMENTS

2. Lay out the elements by "Horizontal" length and position as shown the DIMENSION SHEET. Start with the reflector (longest) element. Balance it on your finger to find rough center and push on a black button insulator to about 1/2" off center. Push the element through the holes of the boom and install the second button, snugging it up into boom. DO NOT BOTHER CENTERING the element at this time and DO NOT INSTALL the stainless steel shaft retainers yet. It is easier to do it after all the horizontal elements are installed in the boom.
3. Install the 3/16" rod DRIVEN ELEMENT as you did the reflector. Then continue with the installation of the DIRECTORS. **Note: the Director Elements do not consistently diminish in length from rear to front, so pay close attention to length and position.**
4. Now begin centering the elements. Use a tape measure to EQUALIZE the amount the element sticking out on each side of the boom. Once you have all the elements centered, sight down the element tips from the rear comparing each side. Look for any obvious discrepancies and correct if found.
5. Stainless steel SHAFT RETAINERS lock the elements in place. They should always be used for permanent and long term antenna installations. For portable or temporary use, the button insulators are adequate for holding the elements and the retainers may be left off.
To install the stainless steel SHAFT RETAINERS, use thumb and forefinger to hold the retainer over the end of the PUSH TUBE (3/8" x 3" tube, supplied in the kit), internal fingers on retainer dished into tube. HOLD THE ELEMENT FIRMLY TO PREVENT IT FROM SLIDING OFF CENTER and press the retainer onto the element end and continue until retainer butts on insulator button. Locking pliers, *lightly* clamped up against opposite button insulator will help maintain center reference (if you push the first retainer too far, remove element from boom, push retainer completely off the element, and start over). Install another retainer to the opposite side of the element. Continue installing retainers until all elements are secured.

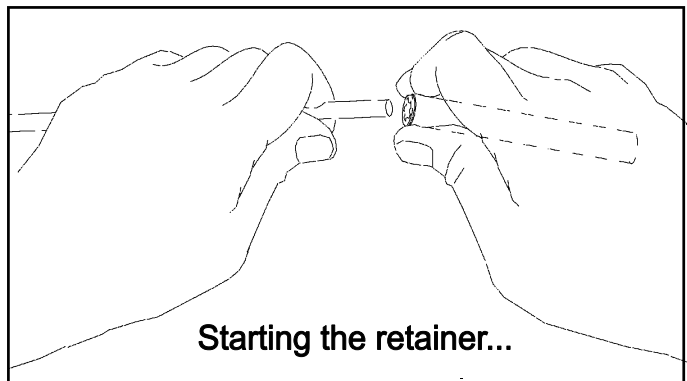

6. Mount the **HORIZONTAL** DRIVEN ELEMENT ASSEMBLY to the **TOP** of the boom with balun connectors oriented to the REAR using a single 8-32 X 1-1/4" screw (SEE DIMENSION SHEET).
7. Install the 8-32 x 1/4" set screws (internal Allen head - tool supplied) into the SHORTING BARS. Slide the bars onto the 1/8" Driven Element Block Rods and the 3/16" driven element rod. **Position the Shorting Bars as shown on dimension sheet.**

450CP42 ASSEMBLY MANUAL

ASSEMBLING THE VERTICAL ELEMENTS

Note: The vertical element set is shifted forward on the boom by 1/4 wave lengths. This increases isolation between element planes, improving circularity and ease of phasing / matching the two element sets.

- Repeat steps #2 through #5 for the Vertical elements, using the Dimension Sheet as your guide to lengths and spacing.

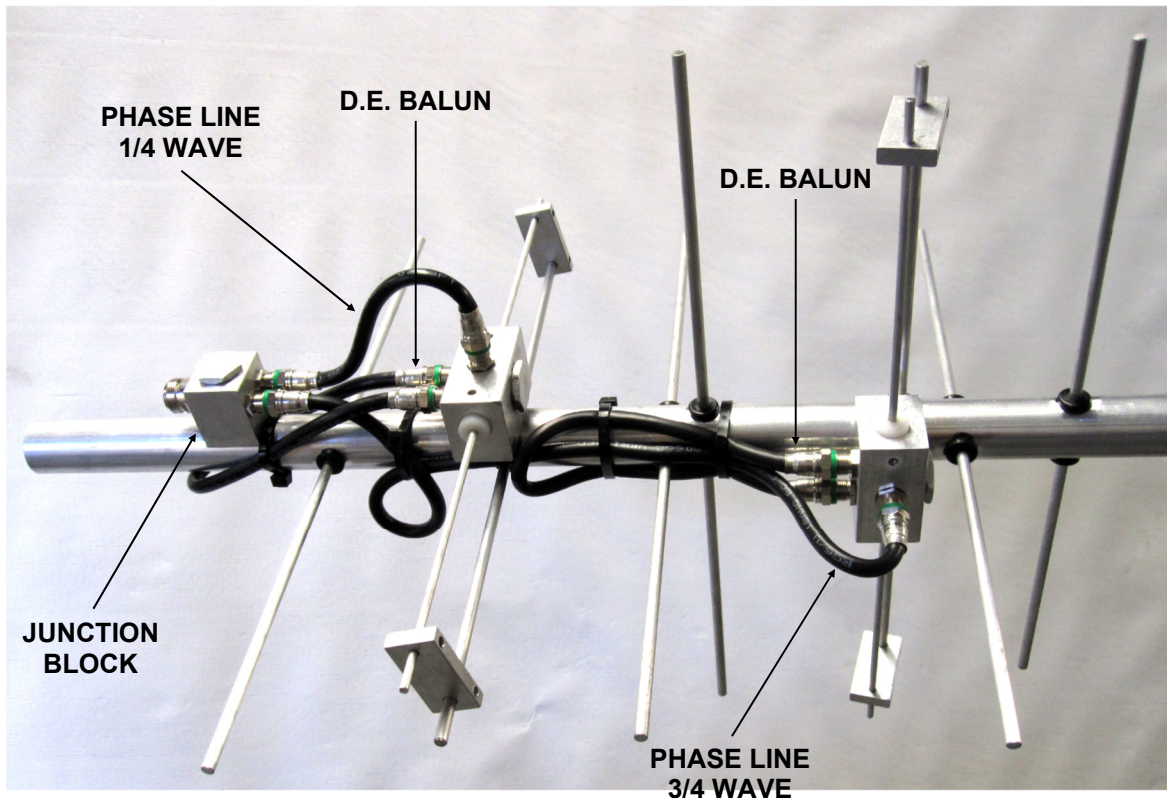

NOTE:
USE 8-32 X 1-1/4" SCREW FOR D.E. BLOCKS AND JUNCTION BLOCK.

INSTALLATION OF THE VERTICAL DRIVEN ELEMENT BLOCK DETERMINES THE CIRCULARITY OF THIS ANTENNA. THE ORIENTATION OF THE BLOCK FOR RHC IS SHOWN ABOVE.

- Viewed from the rear of the boom (rearmost Reflector HORIZONTAL), the VERTICAL Driven Element Block mounts to the LEFT hand side of the boom with the two Balun connectors oriented to the REAR. Secure with 8-32 x 1-1/4" screw. Install the Shorting Bars as in step #7.
- Attach Baluns and Phasing lines to the Driven Element Blocks and Junction Block as shown on the picture above. Tighten the connectors **gently** using a 7/16" end wrench. A lot of torque is unnecessary. Depending on model and polarity, the Vertical balun may loop around another element. This is normal. Form balun coax until it is close to the boom and secure with a nylon cable tie. Also secure the other balun and the matching / phasing harness coax with cable ties. Ties should be snug but not crushing or kinking the coax.
- Use good quality coax and "N" connector for your feedline (see Installation Tips). Secure feed coax near connector on Junction Block, to provide stress relief. Allow about 60" of coax to hang in a loop between the rear end of the boom and the reattachment point (at least 12" beyond element tips) on the mast or crossboom. **Do not route feedline thru boom to mast plate as exiting antenna here will adversely affect circular field.**

450CP42 ASSEMBLY MANUAL

- The boom to mast plate is normally mounted to the boom at the balance point. Since the feed line represents significant weight it is best to have it attached and fastened to the boom with cable ties before final mounting the plate. Use two 1-1/2" U-bolts and the stainless nuts and lock washers provided. DO NOT OVER TIGHTEN. 2" U-bolts (and stainless steel nuts / lockwashers) are provided for mounting the antenna to your NON-CONDUCTIVE mast or crossboom. Other size u-bolts and cradles are available upon request.

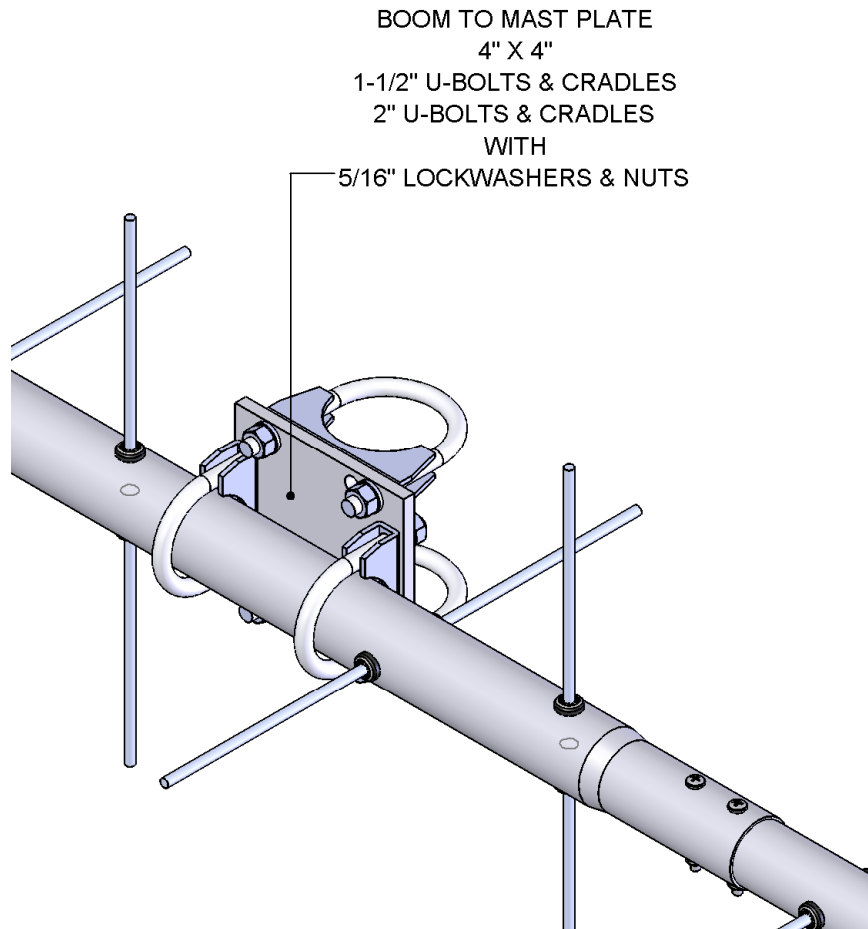

INSTALLATION TIPS

- The 450CP42 is a circular polarized antenna and creates a field in all planes or polarities. Performance **DETERIORATES SIGNIFICANTLY** if it is mounted on a metal (conductive) mast or crossboom. A mast or crossboom of any **NON-CONDUCTIVE** material must be used. Fiberglass is the prime choice for its strength and weather resistance. Mount the 450CP42 so that element tips are at least 12" from any conductive material (mast, tower, feedline, etc.).
- Recommended feedlines, in order of preference:
Andrews or Celwave 1/2" hardline
Times LMR-400 or Belden 8214
Try to keep the cable run to under 100 ft. to prevent excessive signal loss.
- To maintain proper phasing when stacking two or more antennas, mount each with the same orientation of Driven Element Blocks. **DO NOT MOUNT IN MIRROR IMAGE**. See the Specification Sheet for stacking distances. For more detailed stacking information contact M².

450CP42 DIMENSION SHEET

ELEMENT SPACING
HORIZONTAL

REAR OF ANTENNA

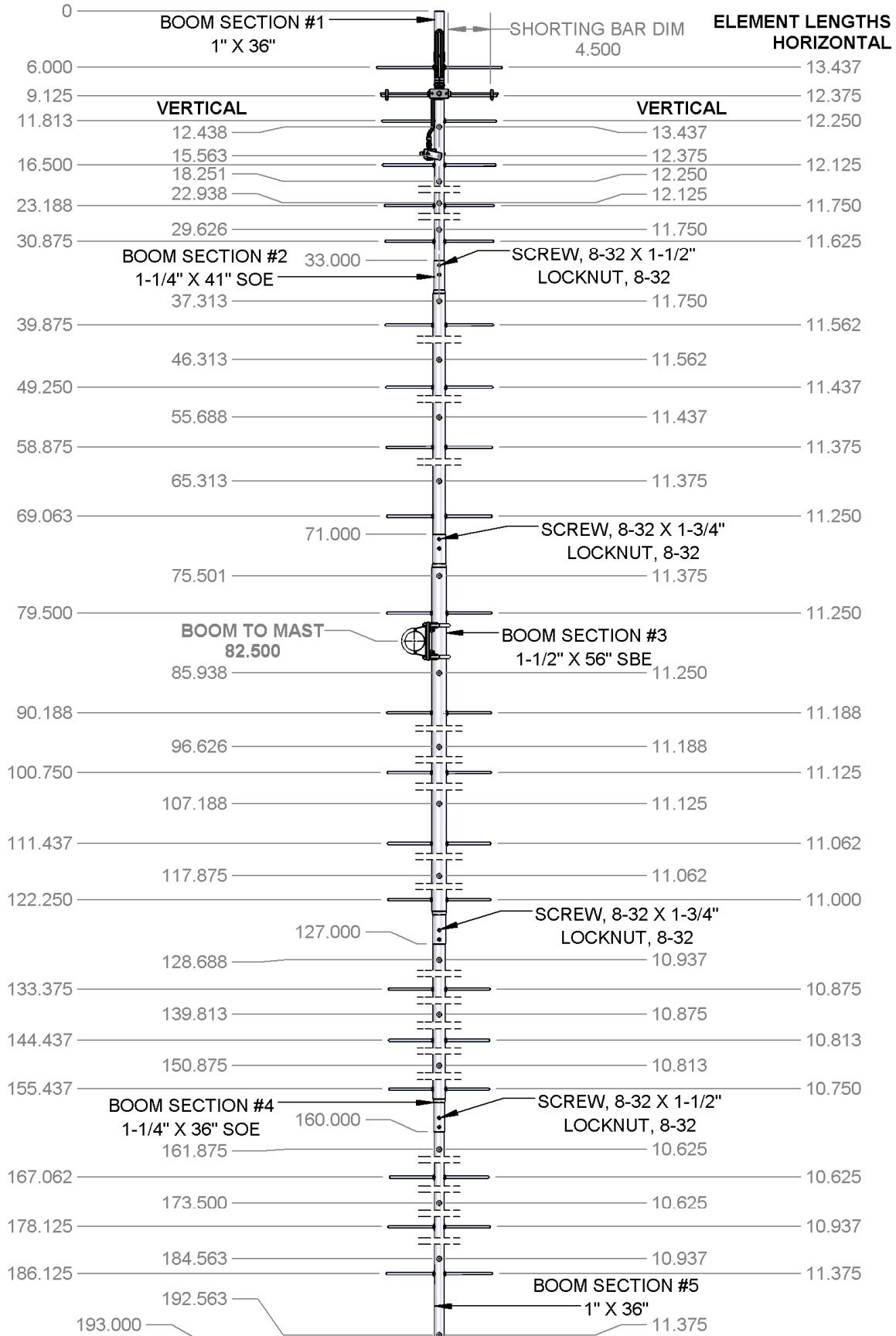

450CP42 PARTS & HARDWARE

DESCRIPTION	QTY
BOOM SECTION # 1, 1.0 X .058 X 36"	1
BOOM SECTION # 2, 1.25 X .058 X 41" SOE	1
BOOM SECTION # 3, 1.50 X .058 X 56" SBE	1
BOOM SECTION # 4, 1.25 X .058 X 36" SOE	1
BOOM SECTION # 5, 1.00 X .058 X 36"	1
ELEMENTS, 3/16 ROD x DIM SHEET	42
DRIVEN ELEMENT ASSEMBLY	2
BALUN FOR D.E. ASSEMBLY (12")	2
PHASE LINE, RG-6 1/4 λ (6.5")	1
PHASE LINE, RG-6 3/4 λ (18")	1
JUNCTION BLOCK ASSEMBLY (SADE0065).....	1
BOOM-TO-MAST PLATE, 4 X 4 X .250" (M2APT0024)	1
SHORTING BAR, 1/4" X 3/4" (M2ASB0080).....	4
U-BOLT & CRADLE, 2"	2
U-BOLT & CRADLE, 1-1/2"	2
PENETROX / ZINC PASTE CUP	1
ASSEMBLY MANUAL	1

HARDWARE:

BUTTON INSULATORS	85
SHAFT RETAINER, SS	85
NUT, 5/16-18 SS.....	8
LOCKWASHER, 5/16 SS	8
SCREW, 8-32 X 1-3/4, SS.....	4
SCREW, 8-32 X 1-1/2, SS.....	4
SCREW, 8-32 X 1-1/4, SS.....	3
LOCKNUT, 8-32 SS.....	8
SETSCREW, 8-32 X 1/4, SS	8
CABLE TIE, 8" NYLON	4
ALLEN HEAD WRENCH, 5/64"	1
PUSH TUBE, 3/8 X 3"	1

M² ANTENNA SYSTEMS, INC.

4402 N. SELLAND AVE.

FRESNO, CA 93722

(559) 432-8873 FAX: 432-3059

www.m2inc.com Email: sales@m2inc.com