

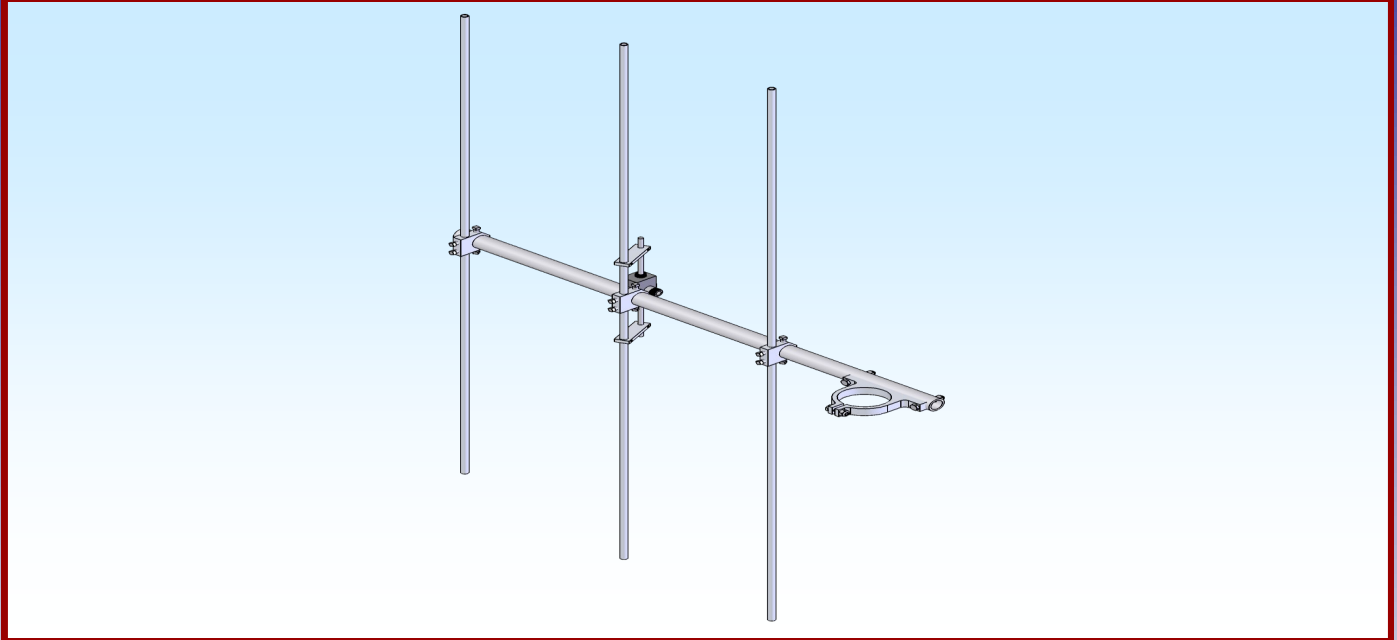

M2 Antenna Systems, Inc.

Model No: 121-3



| | | | |
|------------------------------|--------------------|------------------------------|-----------------------|
| Model | 121-3 | Power Handling | 3 kW, Higher avl. |
| Frequency Range | 121 To 122.5 mHz | Boom Length / Dia | 31.5" / 1" |
| *Gain, (FS) / Over gnd | 7.5 dBi | Maximum Element Length | 48-1/8" |
| Front to back | 20 dB | Turning Radius: | 29" |
| Beamwidth | E= 60° & H= 100° | Stacking Distance | 92" High |
| Feed type | T Match | Mast Size | 2" Nom. |
| Feed Impedance | 50 Ohms Unbalanced | Wind area / Survival | 0.8 Sq. Ft. / 100 MPH |
| Maximum VSWR | 1.5:1 Typical | Weight / Ship Wt. | 2 Lbs. / 6 Lbs. |
| Input Connector | "N" Female | | |

***Subtract 2.14 from dBi for dBd / FS = Free Space**

FEATURES:

Sturdy mechanical design and computer optimized performance make the 121-3 an exceptional antenna. A totally sealed and grounded driven element design with black anodized coating and heavy duty boom will provide optimized performance for years to come. A perfect low profile antenna for high gain phased arrays.

121-3 DIMENSIONS & HARDWARE

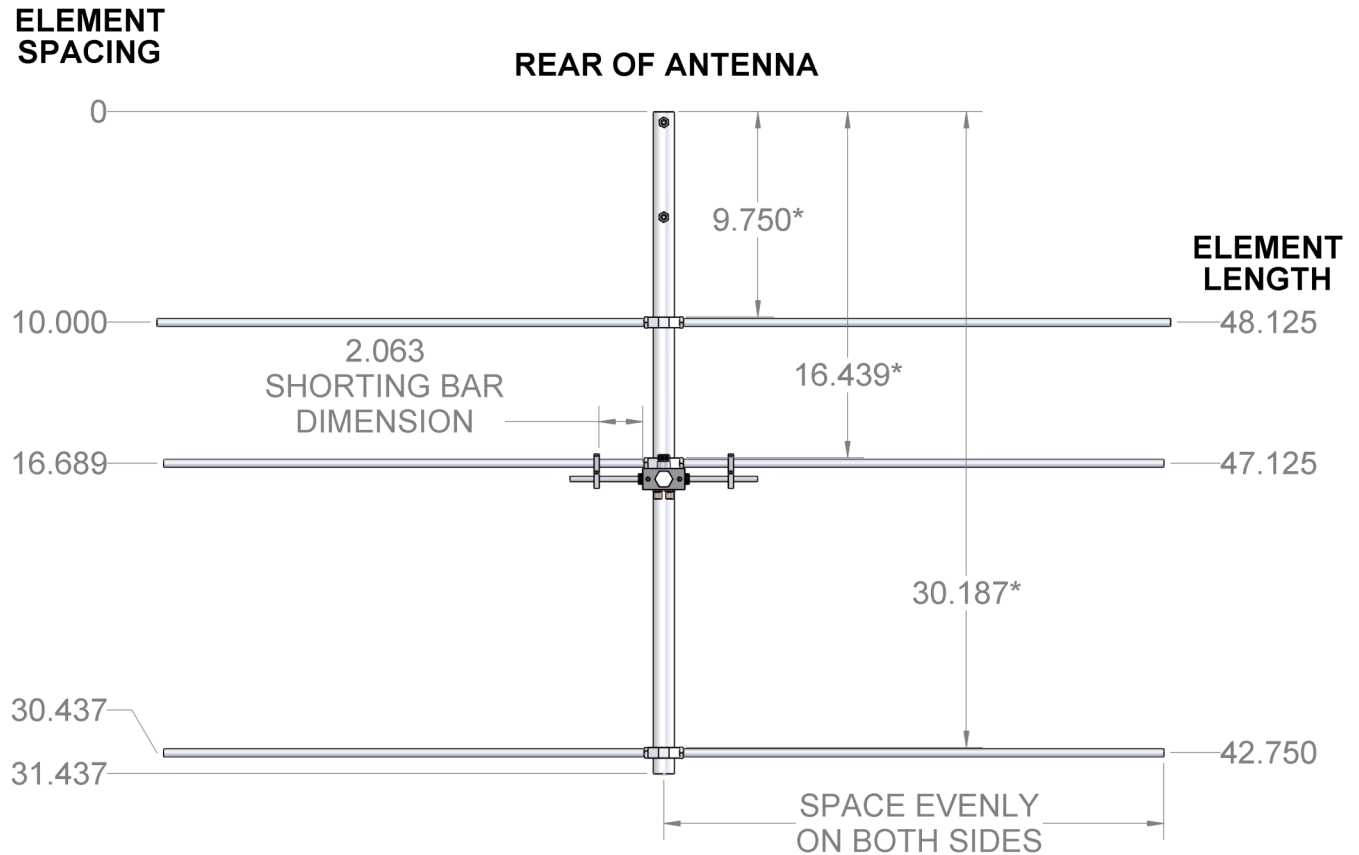

NOTE:

DIMS WITH AN * ARE FROM THE ANTENNA BOOM REAR TO THE FACE OF THE 1" RING CLAMP.

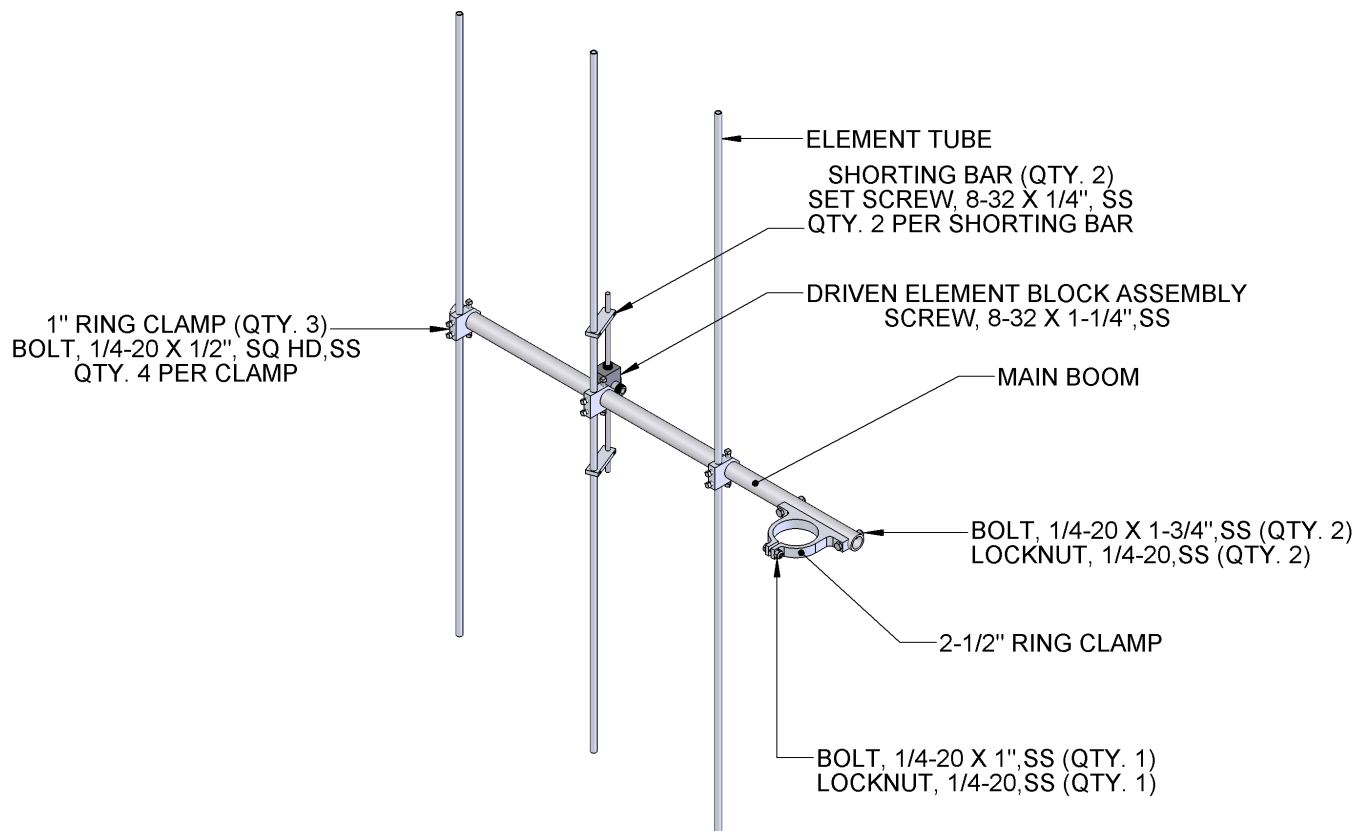

121-3 E-PLANE & H-PLANE PLOTS

M2 120-123 3 Ele
Yagi array 12/13/16

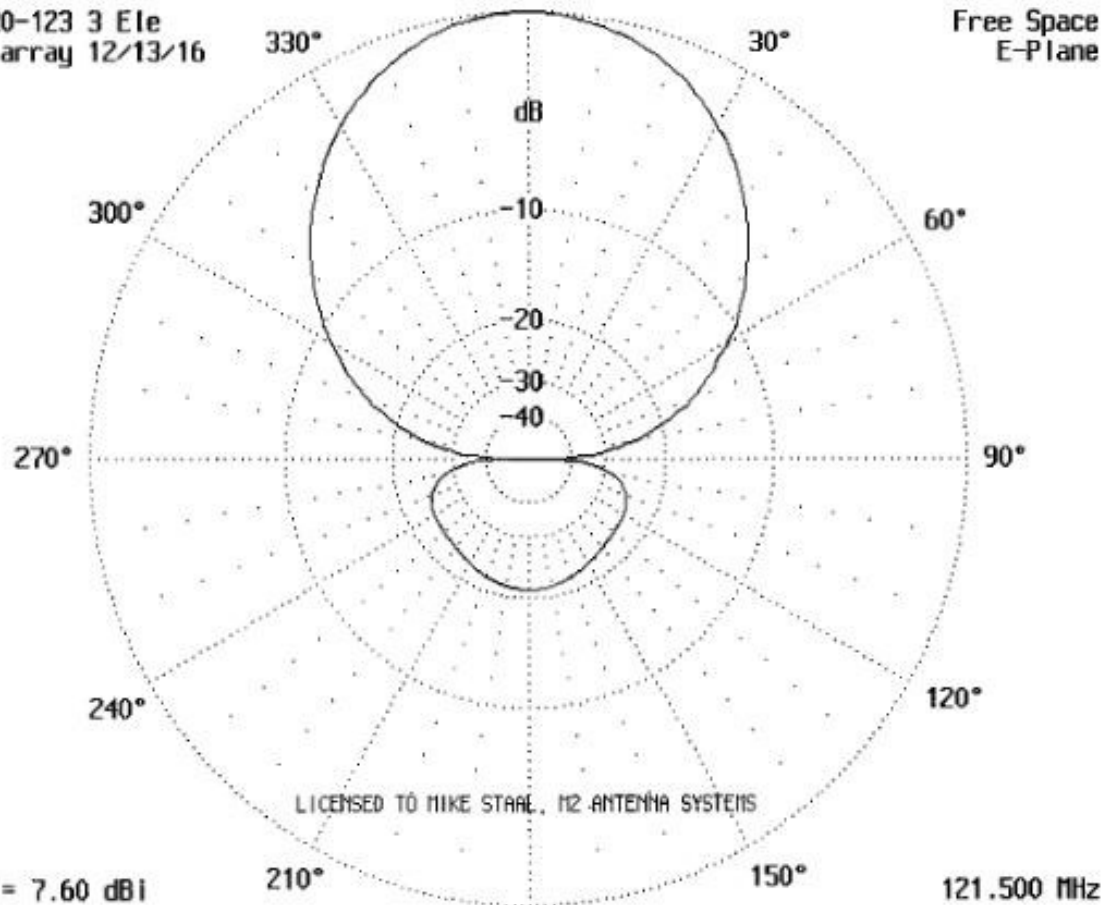

M2 120-123 3 Ele
Yagi array 12/13/16

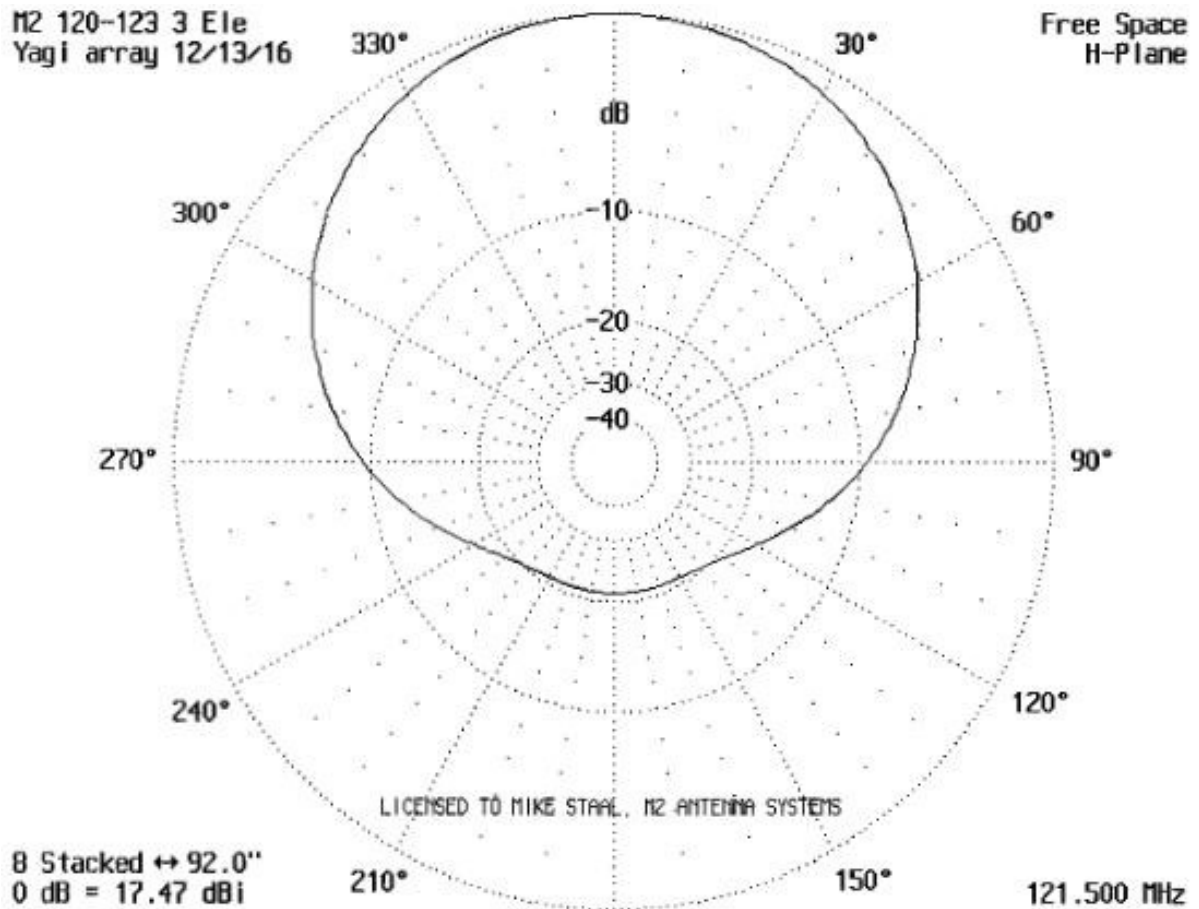

121-3 PARTS & HARDWARE

| DESCRIPTION..... | QTY |
|---|-----|
| BOOM, 1" X .120 X 31-1/2" ALUM TUBE..... | 1 |
| ELEMENT TUBE, 3/8" X .049 X SEE CHART | 3 |
| DRIVEN ELEMENT BLOCK ASSEMBLY | 1 |
| BALUN CABLE, 1/2 WAVE, RG-6U, 43"..... | 1 |
| SHORTING BAR, 1/4" X 3/4" X 2-1/2"..... | 2 |
| RING CLAMP, 1" (M2AEC0250) | 3 |
| RING CLAMP, 2-1/2" (M2AEC0220)..... | 1 |
| USER MANUAL..... | 1 |

IN HARDWARE BAGS:

| | |
|---------------------------------------|----|
| BOLT, 1/4-20 X 1-3/4", SS..... | 2 |
| BOLT, 1/4-20 X 1", SS..... | 1 |
| BOLT, 1/4-20 X 1/2" SQ HEAD, SS | 12 |
| LOCKNUT, 1/4-20, SS..... | 3 |
| SCREW, 8-32 X 1-1/4", SS..... | 1 |
| SET SCREW, 8-32 X 1/4", SS..... | 4 |
| LOCKWASHER, 8-32, SS..... | 1 |
| PENETROX CUP | 1 |
| ALLEN WRENCH, 5/64" | 1 |
| CABLE TIES, MEDIUM | 2 |

M² ANTENNA SYSTEMS, INC.

4402 N. SELLAND AVE.

FRESNO, CA 93722

(559) 432-8873 FAX: 432-3059

www.m2inc.com Email: sales@m2inc.com