

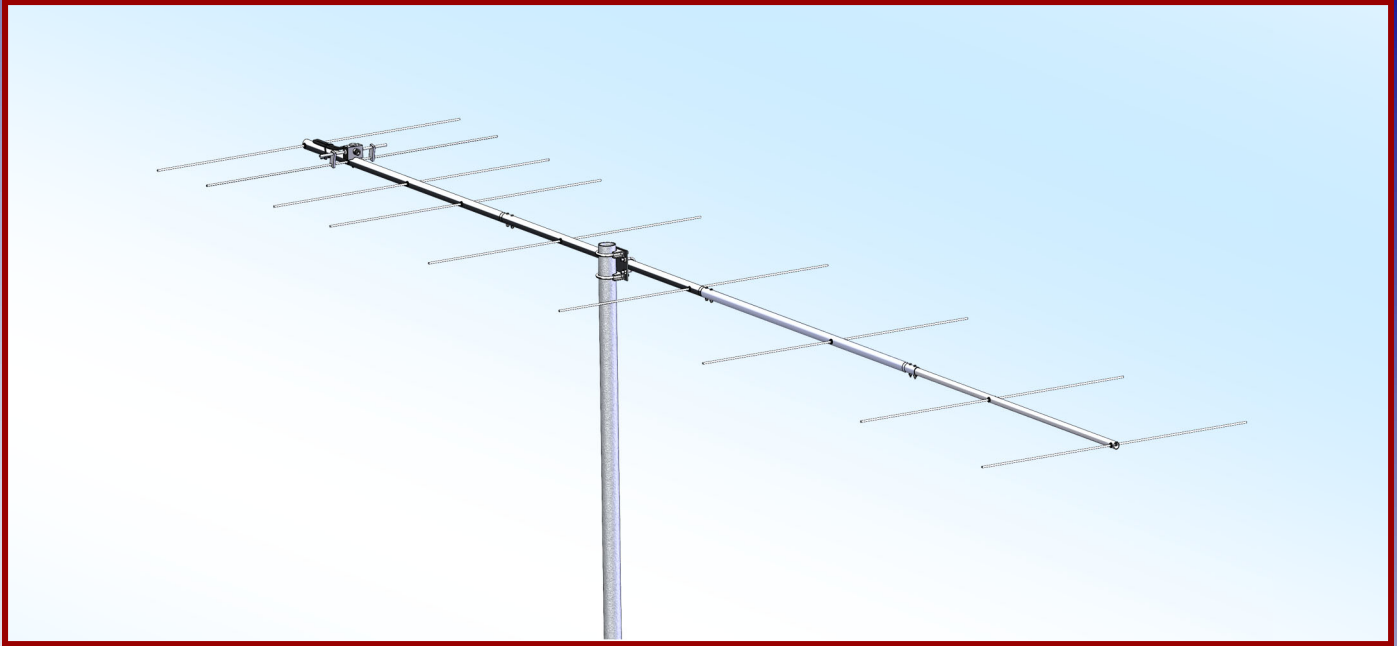

M2 Antenna Systems, Inc. Model No: 122-9



SPECIFICATIONS:

| | | | |
|----------------------|--------------------|-----------------------------|-----------------------|
| Model | 122-9 | Power Handling | 1.5 kW |
| Frequency Range..... | 121 to 124 MHz | Boom Length / Dia..... | 214" / 1-1/2" - 1" |
| *Gain | 14.21 dBi | Maximum Element Length..... | 48" / 3/16" |
| Front to back | 15 dB Typical | Turning Radius: | Call |
| Feed type | "T" Match | Stacking Distance..... | Call |
| Feed Impedance | 50 Ohms Unbalanced | Mounting..... | 1-1/2" to 2" Nom. |
| Maximum VSWR..... | 1.5:1 Typical | Wind area / Survival | 2.0 Sq. Ft. / 100 MPH |
| Input Connector..... | "N" Female | Weight / Ship Wt..... | 11 Lbs. / 14 Lbs. |

***Subtract 2.14 from dBi for dBd**

FEATURES:

Performance has been computer optimized to meet your application. Physical construction emphasizes long term electrical and mechanical durability. Elements are 3/16" 6061-T6 aluminum rod, mounted through the boom on UV stabilized polyethylene button insulators, and locked in position with stainless steel shaft retainers. The "T" Match driven element, uses a CNC machined central block with O-ring sealed connectors. Internal connections are encapsulated in a silicone gel with a dielectric strength 3.7 times greater than air for enhanced power handling. Balun connectors are triple O-ring sealed to the coax.

122-9 ASSEMBLY MANUAL

TOOLS REQUIRED: Screwdriver, 11/32 wrench, socket or spintite, a 7/16" and 1/2" wrench or socket, tape measure. For best results please review instructions before assembly.

1. Start by laying out the boom sections using the DIMENSION sheet as a guide. Use 8-32 x 1-1/2" screws and locknuts to join sections. Sections may be swaged to fit each other or use short internal splice sections.
2. Layout the elements by length and position as shown on the DIMENSION sheet. Start with the reflector (Longest) element and push on a black button insulator to about 1/2" from the center. Push the element through the holes 1/2" from the rear of the boom and install the second button, snugging it up into boom. **DO NOT BOTHER WITH ACCURATELY CENTERING** the element at this time and **DO NOT INSTALL** the stainless steel SHAFT RETAINERS yet. This is easier to do after all the elements are installed in the boom.
3. Install the 3/16" rod DRIVEN ELEMENT as you did the reflector. Then continue with the installation of the DIRECTORS. Note that the Director Elements do not consistently diminish in length from rear to front, so pay close attention to length and position.
4. Now begin centering the elements. Use a tape measure to **EQUALIZE** the amount the element sticking out on each side of the boom. Once you have all the elements centered, sight down the element tips from the rear comparing each side. Look for any obvious discrepancies and correct if found.

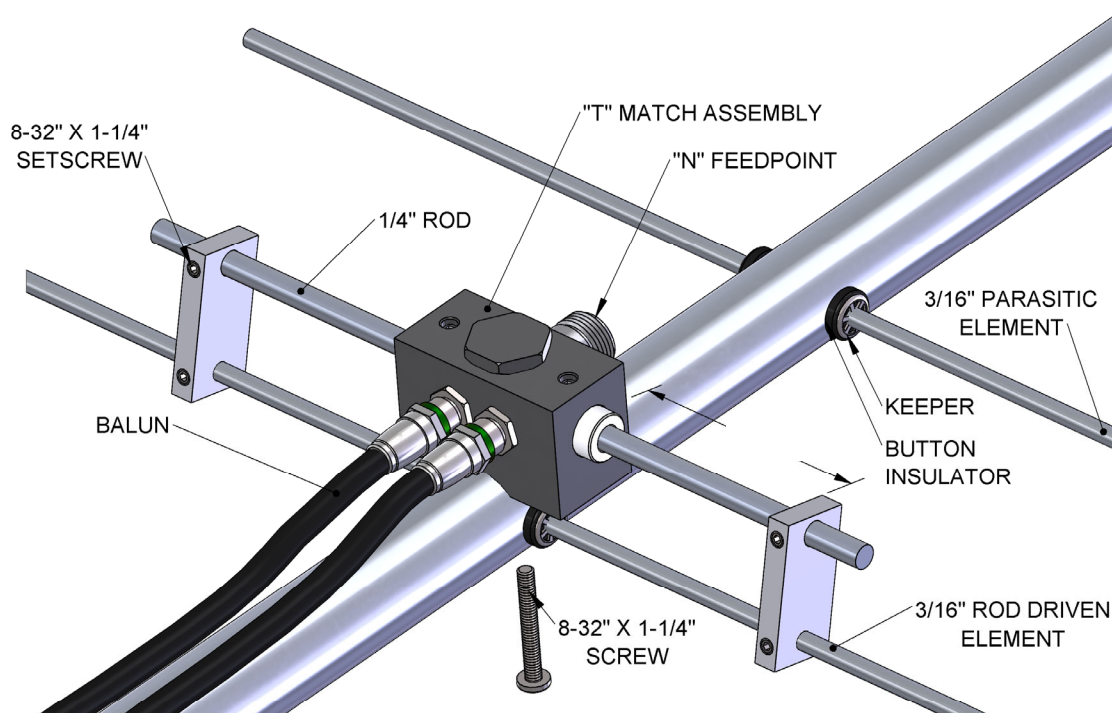

5. NOTE: The SHAFT RETAINERS, used for securing the elements, should always be used for permanent and long term antenna installations. For portable or temporary use, or whenever it is anticipated that the antenna will be disassembled with a short time, the retainers may be left off. The button insulators, normally a tight fit, hold the elements quite securely. Begin installing the stainless shaft retainers. Use thumb and index finger to hold a Shaft Retainer over end of the 3/8" x 3" push tube. (Shaft Retainer dished into tube). Hold the element firmly and start the keeper onto the rod by applying pressure with the push tube. Push the Shaft Retainer until up tight

122-9 ASSEMBLY MANUAL

Against the button insulator (Locking pliers, lightly clamped up against the opposite button insulator will help maintain center reference and keep you from pushing the first Shaft Retainer too far). Repeat for the opposite side. Continue installing Shaft Retainers until all elements are locked in place.

6. Mount the DRIVEN ELEMENT T-MATCH BLOCK to the underside of the boom using a single 8-32 x 1-1/4" screw and lock washer. Orient the block with the feed connector facing to center and balun connectors facing to rear. Block orientation may be reversed if you wish feedline to exit from rear of boom.

7. Coil the balun so it will not extend beyond the reflector when installed. Attach balun to the Block and tighten the connectors gently using a 7/16" end wrench. A lot of torque is unnecessary. Squeeze the balun coil across the middle until it is close to the boom and secure to boom with a nylon cable tie. Tie should be snug but not crushing or kinking the coax.

8. Install the 8-32 x 1/4" set screws (internal Allen head—tool supplied) into the SHORTING BARS. Slide the bars onto the 3/16" rod driven element tips and then onto the Driven Element Block Rods. Position the Shorting Bars as specified on the DIMENSION SHEET: the distance given is between the outer edge of the Driven Element Block and the inner edge of the Shorting Bar. Align the bars and rods with each other and tighten the set screws.

9. The boom to mast plate is normally mounted at the balance point. Use two 1" U-bolts and the stainless nuts and lock washers provided. DO NOT OVER TIGHTEN. 2" U-bolts and cradles are provided for mounting the antenna, other sizes are available upon request. Since the feedline represents significant weight it is best to have it attached and fastened along the boom with cable ties before final mounting the plate.

THIS COMPLETES THE ANTENNA ASSEMBLY.

122-9 DIMENSION SHEET

122-9 DIMENSIONS

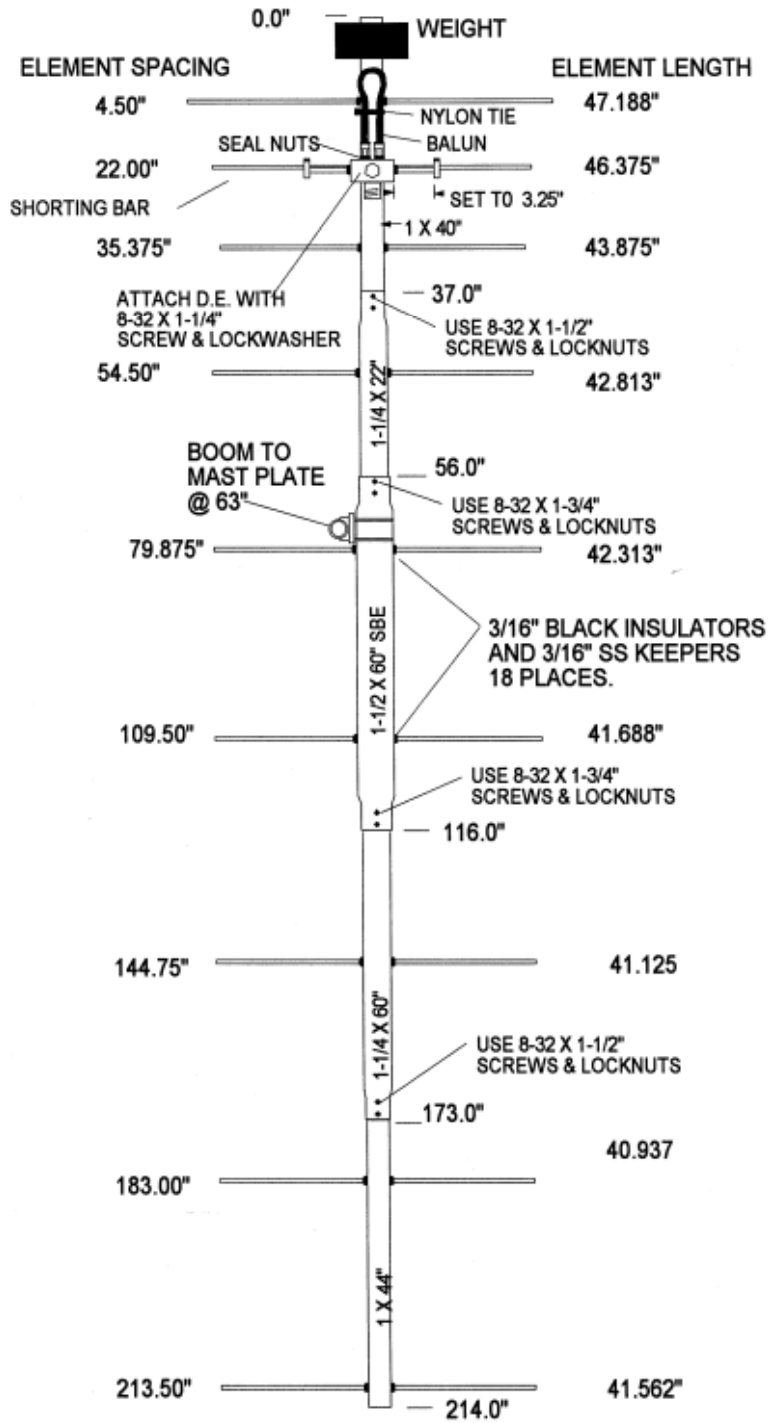

122-9 PARTS & HARDWARE

| DESCRIPTION | QTY |
|--|-----|
| BOOM SECTION, 1-1/2" X .058 X 60" SBE | 1 |
| BOOM SECTION, 1-1/4" X .058 X 60" SOE..... | 1 |
| BOOM SECTION, 1-1/4" X .058 X 22" SOE..... | 1 |
| BOOM SECTION, 1" X .058 X 40" STR | 1 |
| BOOM SECTION, 1" X .058 X 44" STR | 1 |
| ELEMENT SET, 3/16" X SEE DIMENSION SHEET | 9 |
| DRIVEN ELEMENT ASSEMBLY | 1 |
| BALUN, RG-6 | 1 |
| BOOM TO MAST PLATE, .188" X 4" X 6" | 1 |
| U-BOLT AND CRADLE, 1-1/2" | 2 |
| U-BOLT AND CRADLE, 2" | 2 |
| ASSEMBLY MANUAL | 1 |

IN HARDWARE BAG

| | |
|---------------------------------------|----|
| SHORTING BAR | 2 |
| BUTTON INSULATORS, 3/16" | 18 |
| SHAFT RETAINER, 3/16" SS..... | 18 |
| NUT, 5/16-18 SS | 8 |
| LOCKWASHER, 5/16" SPLIT RING SS | 8 |
| SET SCREW, 8-32 X 1/4"..... | 4 |
| SCREW, 8-32 X 1-3/4" SS..... | 4 |
| SCREW, 8-32 X 1-1/2" SS..... | 4 |
| SCREW, 8-32 X 1-1/4" SS..... | 1 |
| LOCKNUT, 8-32 SS..... | 8 |
| LOCKWASHER, #8 SPLIT RING | 1 |
| NYLON TIE..... | 2 |
| SEAL NUT, 3/8-32 | 2 |
| ALLEN WRENCH, 5/64" | 1 |
| PUSH TUBE, 3/8" X 3" | 1 |

Carefully Manufactured by
 M2 Antenna Systems, Inc.
 4402 N. Selland Ave.
 Fresno, CA 93722
 (559) 432-8873 Fax (559) 432-3059
 www.m2inc.com email: sales@m2inc.com