

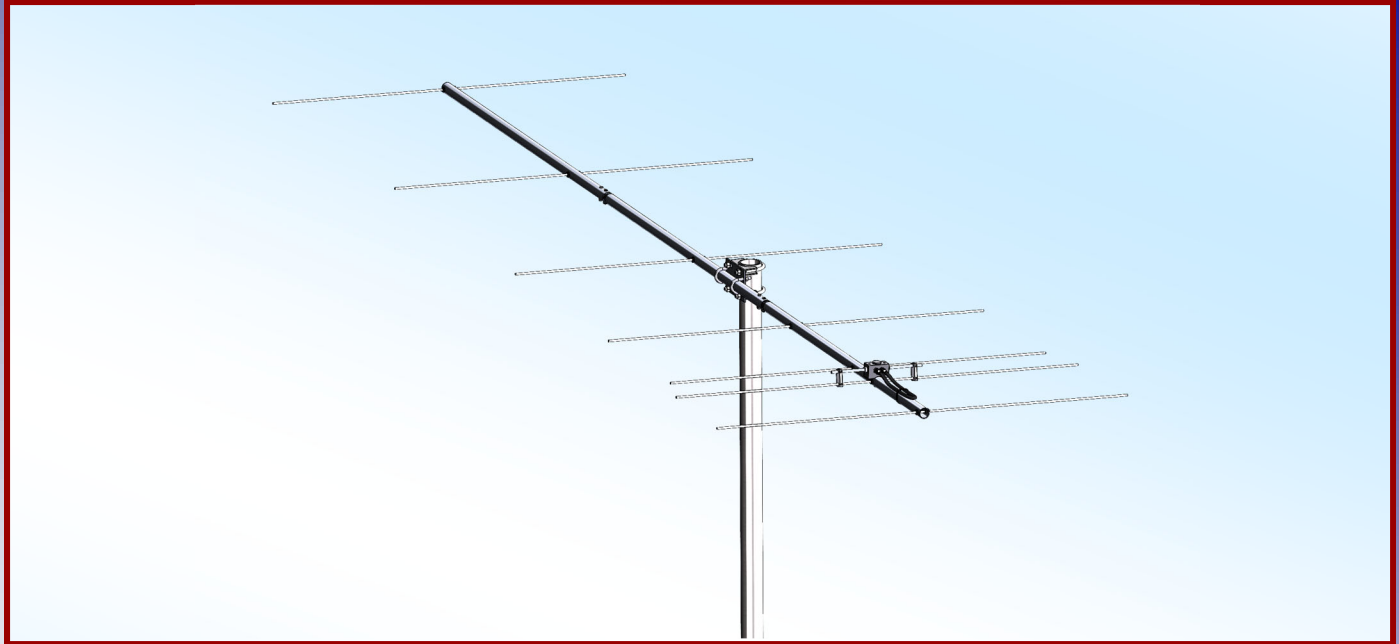

# M2 Antenna Systems, Inc. Model No: 138-6



### SPECIFICATIONS:

Model .....	138-6	Power Handling .....	1.5 kW
Frequency Range.....	137 to 139 MHz	Boom Length / Dia.....	103" / 1"
*Gain .....	11.91 dBi	Maximum Element Length.....	43" / 3/16"
Front to back .....	23 dB Typical	Turning Radius: .....	Call
Feed type .....	"T" Match	Stacking Distance.....	Call
Feed Impedance .....	50 Ohms Unbalanced	Mast Size.....	1-1/2" to 2" Nom.
Maximum VSWR.....	1.5:1 Typical	Wind area / Survival .....	0.8 Sq. Ft. / 100 MPH
Input Connector.....	"N" Female	Weight / Ship Wt.....	6 Lbs. / 8 Lbs.

**\*Subtract 2.14 from dBi for dBd**

### FEATURES:

Performance has been computer optimized to meet your application. Physical construction emphasizes long term electrical and mechanical durability. Elements are 3/16" 6061-T6 aluminum rod, mounted through the boom on UV stabilized polyethylene button insulators, and locked in position with stainless steel shaft retainers. The "T" Match driven element, uses a CNC machined central block with O-ring sealed connectors. Internal connections are encapsulated in a silicone gel with a dielectric strength 3.7 times greater than air for enhanced power handling. Balun connectors are triple O-ring sealed to the coax

# 138-6 ASSEMBLY MANUAL

Tools handy for assembly process: screwdriver, 11/32" spin-tite or socket, 7/16" and 1/2" end wrenches and/or sockets, measuring tape.

1. Assemble the boom sections using the 8-32 X 1-1/4 screws and locknuts.
2. Lay out the elements by length and position as shown the DIMENSION sheet. Start with the REFLECTOR (longest) element. Balance on finger to find rough center and push on a black button insulator to about 1/2" from center. Install the element through the holes at the boom and push on the second button, snugging it up into boom. DO NOT BOTHER WITH ACCURATELY CENTERING the element at this time and DO NOT INSTALL the stainless steel SHAFT RETAINERS yet. This is easier to do after all the elements are installed in the boom.
3. Install the 3/16" rod DRIVEN ELEMENT as you did the reflector. Then continue with the installation of the DIRECTORS.
4. Now begin centering the elements. Use a tape measure to EQUALIZE the the element length on each side of the boom. Once you have all the elements centered, sight down the element tips from the rear comparing each side. Look for any obvious discrepancies and correct if found.
5. Begin installing the stainless SHAFT RETAINER to one side of the element. Use thumb and index finger to hold a retainer over end of the 3/8 x 3" push tube (chamfer inner edge of tube) (retainer dished into tube). Hold the element firmly and start the retainer onto the rod by applying pressure with the push tube. Push the retainer until up tight against the button insulator (Locking pliers, *lightly* clamped up against opposite button insulator will help maintain center reference and keep you from pushing the first retainer too far). It is a good idea to install the second SHAFT RETAINER after final testing.
6. Mount the DRIVEN ELEMENT ASSEMBLY to the underside of the boom using a single 8-32 X 1-1/4" screw. Orient the block with feed connector facing forward and balun connectors facing to rear. Block orientation may be reversed if you wish feedline to exit rear of boom.
7. Attach balun to the DRIVEN ELEMENT ASSEMBLY and tighten the connectors *gently* using a 7/16" end wrench. Coil balun once, if necessary, so balun does not extend beyond end of boom. Form the balun close to the boom and secure with a nylon cable tie, snug but not crushing or kinking the coax.

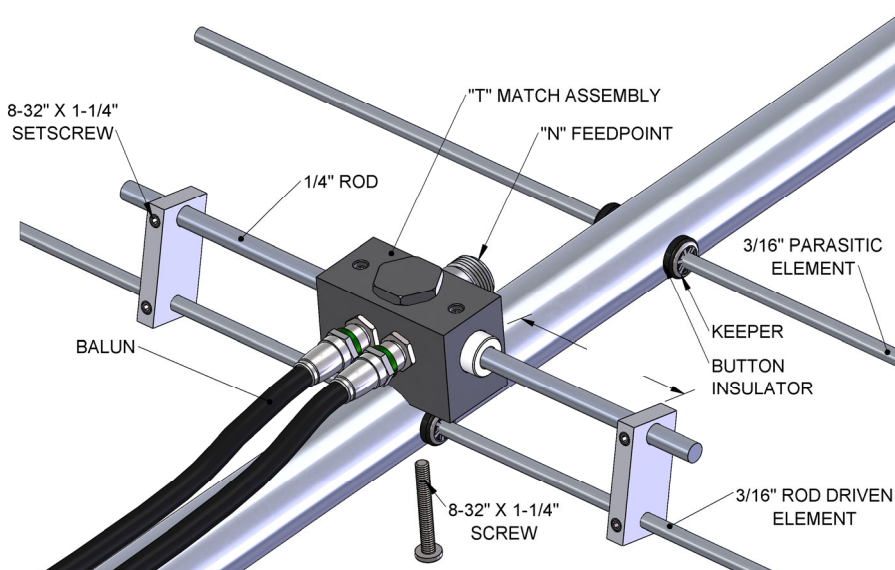

# 138-6 DIMENSION SHEET

## 138-6 DIMENSION SHEET

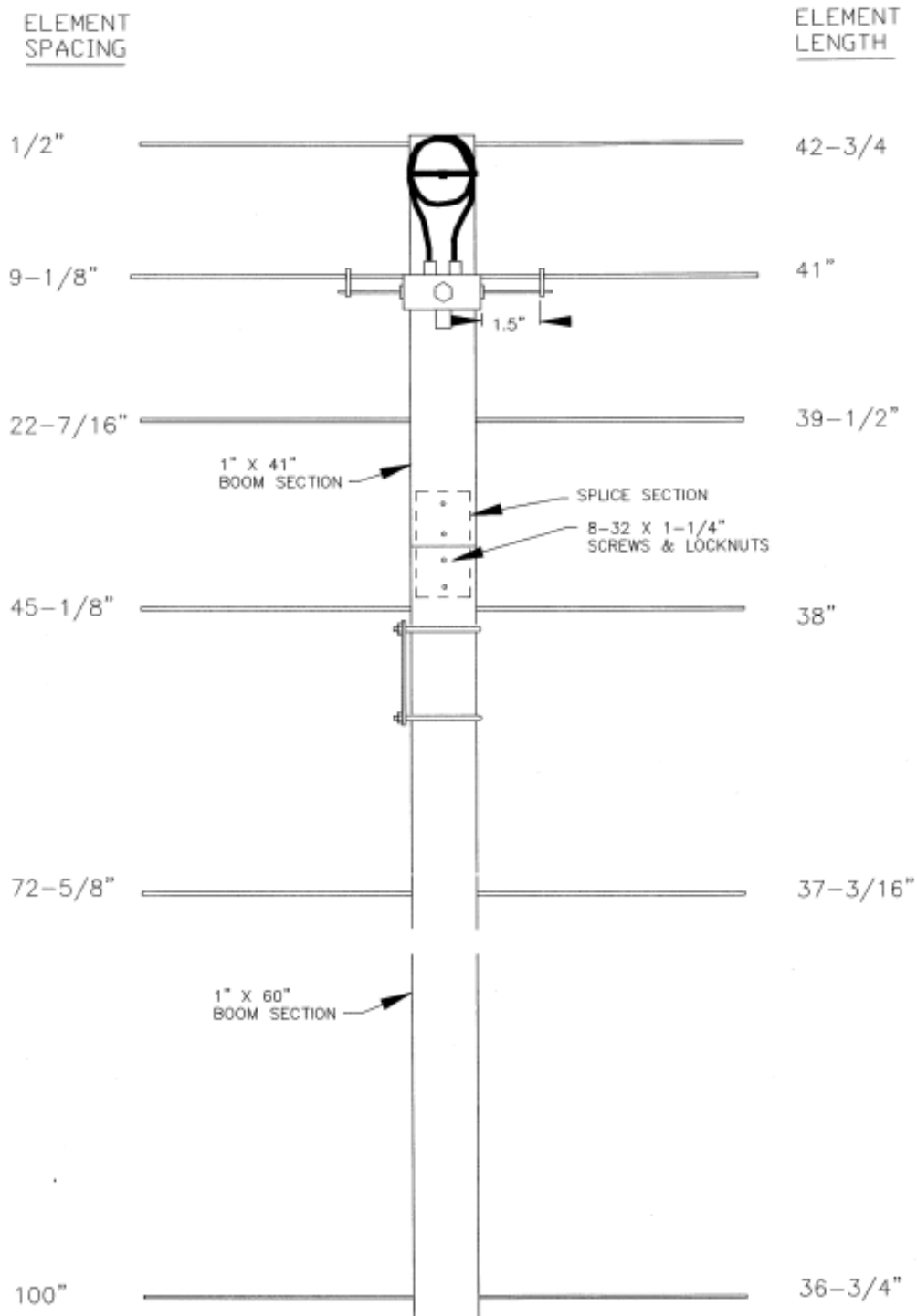

# 138-6 ASSEMBLY MANUAL

8. Install the 8-32 x 1/4" set screws (internal Allen head - tool supplied) into the SHORTING BARS. Slide the bars onto the 3/16" rod driven element tips and then onto the Driven Element Block Rods. Position the Shorting Bars as specified on the Dimension Sheet: 1.5" from the outer face of the block to the inner face of the bar. Align the bars and rods with each other and tighten the set screws.
9. The boom to mast plate is normally mounted at the balance point. Since the feedline represents significant weight it is best to have it attached and fastened along the boom with cable ties before final mounting of the plate. Use two 1" U-bolts and the stainless nuts and lock washers provided (no cradles are used). **DO NOT OVER TIGHTEN.** 2" U-bolts are provided for mounting the antenna to your mast. Never mount to a metallic mast or cross boom in the same plane as the elements. Pattern and performance will deteriorate. See next step.

## 10. INSTALLATION AND TESTING STACKING INFORMATION

**A.** To protect your investment in this high performance antenna, always use high quality coax and connectors. Old, corroded, or poor quality materials are common sources of serious performance losses.

**B.** Test the antenna, connectors and feedline, **BEFORE** installing to your mast or tower. At 6 feet or more the antenna will exhibit VSWR *similar* to higher mounting heights. Set antenna on a ladder or temporary mast. Check for continuity and match across the band. It should be close to "spec" across the rated bandwidth. When satisfied, add the second SHAFT RETAINERS as described in step 5.

### **C. STACKING REMINDERS:**

1. All driven element blocks **MUST** be oriented to the same side of boom.
2. All boom-to-mast plates **MUST** be mounted at the same point on the boom.
3. Feed / phasing lines **MUST** be of equal electrical length or multiples of 1/2 wavelength in order to maintain equal phasing in the array. Improper phasing can severely deteriorate performance.
4. As a general rule, you never want to have metallic structures, such as a mast or feed lines parallel to the elements unless it is behind the reflector. Having metallic structure in the same plane as the elements in front of the reflector element can cause VSWR problems and or skewed patterns.

**FOR HORIZONTAL POLARIZATION**, the antenna may be mounted to a **METALLIC** vertical mast or a horizontal **NON-METALLIC** cross boom. If mounted to a horizontal cross boom, route the feedline forward to the boom-to-mast plate, loop down, and bring back to cross boom at least 6" beyond element tips. Antennas are typically stacked one above the other in horizontal polarity. **SEE SPEC SHEET FOR STACKING DISTANCE.** See Stacking Reminders.

**FOR VERTICAL POLARIZATION**, the antenna may be mounted to a **NON METALLIC VERTICAL MAST** or a horizontal **METALLIC** cross boom. If mounted to a **NON METALLIC** vertical mast, Turn the driven element 180 degrees so the feed line and "N" connector is facing to the rear of the antenna, route the feed line to the rear of the antenna keeping 4" to 6" behind the reflector element. Let the cable droop at least 6 inches **BELOW THE VERTICAL ELEMENT TIPS.** Re-attach the feed line to the mast below the element tips. A simple structure can easily be fabricated if you want something to support the feed line. See M2 "L" brace kit for ideas. Vertically polarized Antennas are typically stacked side by side on a horizontal cross boom. See Stacking Reminders.

If you are unsure about stacking multiple antennas, please call **M<sup>2</sup>** and let us help you **DO IT RIGHT!** Visit our website, <https://www.m2inc.com/blog/> for other tips.

# 138-6 PARTS & HARDWARE

DESCRIPTION	QTY
BOOM SECTION, 1" X .058 X 60" .....	1
BOOM SECTION, 1" X .058 X 41" .....	1
SPLICE SECTION, 7/8" .....	1
ELEMENT SET, 3/16" ROD X SEE DIMENSION SHEET.....	6
DRIVEN ELEMENT ASSEMBLY .....	1
BALUN, RG-6.....	1
BOOM TO MAST PLATE, .188" X 3" X 4".....	1
U-BOLT, 1".....	2
U-BOLT AND CRADLE, 2".....	2
ASSEMBLY MANUAL.....	1

## IN HARDWARE BAG

SHORTING BAR.....	2
BUTTON INSULATOR, 3/16".....	12
KEEPER, 3/16" SS.....	12
NUT, 5/16-18 SS.....	4
LOCKWASHER, 5/16" SPLIT RING SS.....	4
NUT, 1/4-20 SS.....	4
LOCKWASHER, 1/4-20 SPLIT RING SS.....	4
SET SCREW, 8-32 X 1/4".....	4
SCREW, 8-32 X 1-1/4".....	5
NYLOCK NUT, #8 SS.....	4
NYLON TIE.....	3
SEAL NUT, 3/8-32.....	2
ALLEN WRENCH, 5/64".....	1
PUSH TUBE, 3/8" X 3".....	1

Carefully manufactured by:

M2 ANTENNA SYSTEMS, INC.  
4402 N. Selland Ave.  
Fresno, CA 93722  
(559) 432-8873 Fax: 432-3059  
www.m2inc.com Email: sales@m2inc.com

7-5-90  
Rev: 3-22-91  
3-21-03  
3-15-21