

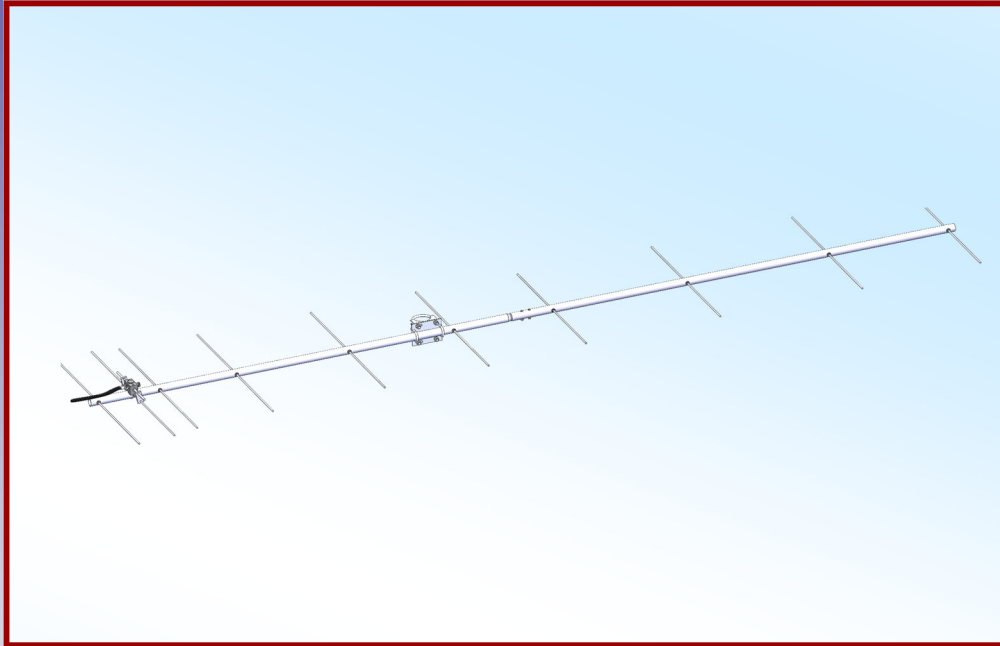

# M2 Antenna Systems, Inc. Model No: 213-10



## SPECIFICATIONS:

Model .....	213-10	Power Handling .....	1.5 kW
Frequency Range.....	210-217 MHz	Boom Length / Dia.....	123" / 1"
*Gain .....	14.14 dBi	Maximum Element Length.....	28"
Front to back .....	24 dB Typical	Turning Radius: .....	Call
Beamwidth .....	E=34° H=40°	Stacking Distance.....	80" High & 70" Wide
Feed type .....	"T" Match	Mast Size.....	1-1/2" to 2" Nom.
Feed Impedance.....	50 Ohms Unbalanced	Wind area / Survival .....	0.075 Sq. Ft. / 100MPH
Maximum VSWR.....	1.5:1 Typical	Weight / Ship Wt.....	4 Lbs. / 5 Lbs.
Input Connector.....	"N" Female		

**\*Subtract 2.14 from dBi for dBd**

## FEATURES:

The 213-10 is an easily assembled, medium sized, computer designed Yagi that covers 210 to 217 MHz. Original designed for channel 13 TV stations, this antenna has a flat gain and VSWR. Strong, yet lightweight and streamlined, it compliments any VHF system. The heart of the 213-10 is a unique Driven Element Module with superior weather resistance and power handling abilities. All connectors are O-ring sealed to the CNC machined block and internal connections are sealed in a space-age silicone gel with a dielectric strength nearly 4 times greater than air. The Balun coax connectors are triple sealed.

Other key mechanical and electrical parts are CNC machined from 6061-T6 aluminum and all hardware except U-bolts is stainless steel. It features our silicone-gel sealed, weatherproof driven element assembly and a unique internal balun. Want higher power capability or some other change? Please contact the factory for details.

# 213-10 ASSEMBLY MANUAL

Tools required: screwdriver, 11/32", 7/16", and 1/2" end wrenches and / or sockets, measuring tape.

1. Assemble the two 1" boom sections using 8-32 x 1-1/4" screws and locknuts.
2. Lay out the 3/16" elements by length and position as shown the DIMENSION sheet. Start with the REFLECTOR element. Balance across finger to find center and push on a black button insulator to about 1/2" from center. Push the element through the holes 1/2" from the rear of the boom and install the second button, snugging it up into boom. **DO NOT BOTHER WITH ACCURATELY CENTERING** the element at this time and **DO NOT INSTALL** the shaft retainers yet. This is easier to do after all the elements are installed in the boom.
3. Install the DRIVEN ELEMENT as you did the reflector. Then continue with the installation of the DIRECTORS. **Note that the Director Elements do not consistently diminish in length from rear to front, so pay close attention to length and position.**
4. Now begin centering the elements. Use a tape measure to EQUALIZE the amount the element sticking out on each side of the boom. Once you have all the elements centered, sight down the element tips from the rear comparing each side. Look for any obvious discrepancies and correct if found.
5. Install the stainless steel SHAFT RETAINERS onto the element rods. NOTE: The shaft retainers should always be used for permanent and long term antenna installations. For portable or temporary use, or whenever it is anticipated that the antenna will be disassembled within a short time, the retainers may be left off. The button insulators, alone, hold the elements quite securely.

To install, use thumb and index finger to hold a retainer over end of the 3/8 x 3" push tube (retainer dished into tube). Hold the element firmly and start the retainer onto the rod by applying pressure with the push tube. Push the retainer until up tight against the button insulator. Locking pliers, **lightly** clamped to rod and up against opposite button insulator will help maintain center reference. If the retainer is pushed too far, remove the element from the boom, push the retainer off, and start over. Install opposing retainer. Repeat for all elements.

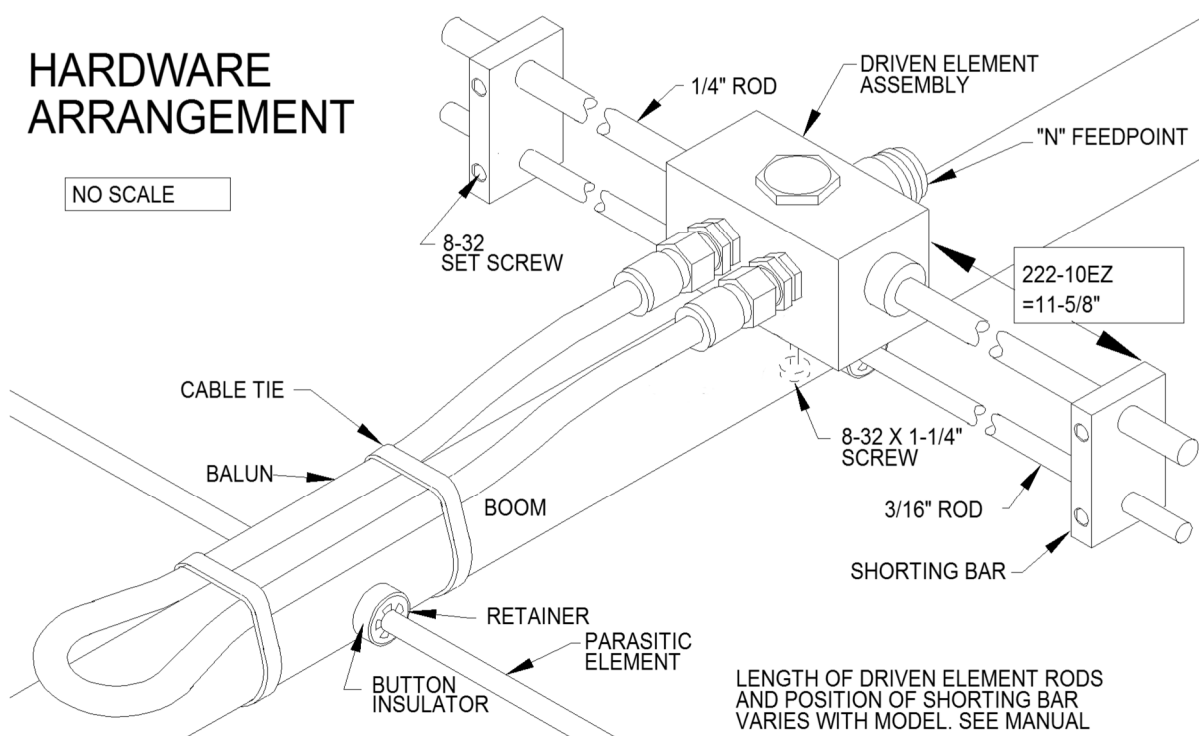

# 213-10 ASSEMBLY MANUAL

6. Mount the DRIVEN ELEMENT BLOCK ASSEMBLY to the top of the boom using a single 8-32 X 1-1/4" screw. Orient the block with feed connector facing to the FRONT.
7. Attach balun, routing coax along boom in a single loop. Tighten the connectors **gently** using a 7/16" end wrench. Form the balun close to the boom and secure with a nylon cable tie. Tie should be snug but not crushing or kinking the coax.
8. Install the 8-32 x 1/4" set screws (internal Allen head - tool supplied) into the SHORTING BARS. Slide the bars onto the 3/16" rod driven element tips and then onto the 1/4" Driven Element Block Rods. Position the Shorting Bars according to the Dimension Sheet or drawing on previous page: the dimension is between the outer face of the driven element block and the inner face of the shorting bar. Align the bars and rods with each other and tighten the setscrews.
10. The boom to mast plate is normally mounted at the balance point. Since the feed line represents significant weight it is best to have it, or a temporary equivalent, attached and fastened along the boom with cable ties before final mounting the plate. Use two 1" U-bolts and the stainless locknuts provided. DO NOT OVER TIGHTEN. 2" U-bolts are provided for mounting the antenna to your mast.

THIS COMPLETES THE ANTENNA ASSEMBLY.

## INSTALLATION AND STACKING INFORMATION

**A. Never mount the antenna with a metallic mast, crossboom or feedline in the element plane: pattern and performance will deteriorate.** Use a fiberglass or equivalent mast or crossboom instead. Route feedline at right angles to elements when exiting boom.

HORIZONTALLY POLARIZED, the antenna may be mounted to a metallic vertical mast or a horizontal NON-METALLIC crossboom. If mounted to a horizontal crossboom, route the feedline forward to the boom-to-mast plate, loop down at right angles to the elements, and bring back to crossboom at least 6" beyond element tips.

VERTICALLY POLARIZED, the antenna may be mounted to a NON METALLIC VERTICAL MAST or a horizontal metallic crossboom. If mounted to a vertical mast, route the feed line forward to the boom-to-mast plate, loop out at a right angle to the boom, and bring down to the mast at least 6 inches below the element tips.

B. To optimize the performance of this high quality antenna, always use high quality coax and connectors. Old, corroded, or poor quality materials are common sources of serious performance losses and VSWR problems.

C. If possible, test the antenna, connectors and feedline BEFORE installing to your mast or tower. At 6 feet or more the antenna will exhibit performance **similar** to higher mounting heights. Set antenna on a ladder or temporary mast. Check for continuity and that match is close to "specs" across the the rated bandwidth.

### D. STACKING REMINDERS:

1. All driven element blocks MUST be oriented to the same side of boom.
2. All boom-to-mast plates MUST be mounted at the same point on the boom.
3. Feed / phasing lines MUST be of equal electrical length or multiples of 1 wavelength in order to maintain equal phasing in the array. Improper phasing can severely deteriorate performance.

If you are unsure about stacking multiple antennas, please call **M<sup>2</sup>** and let us help you DO IT RIGHT

# 213-10 DIMENSION SHEET

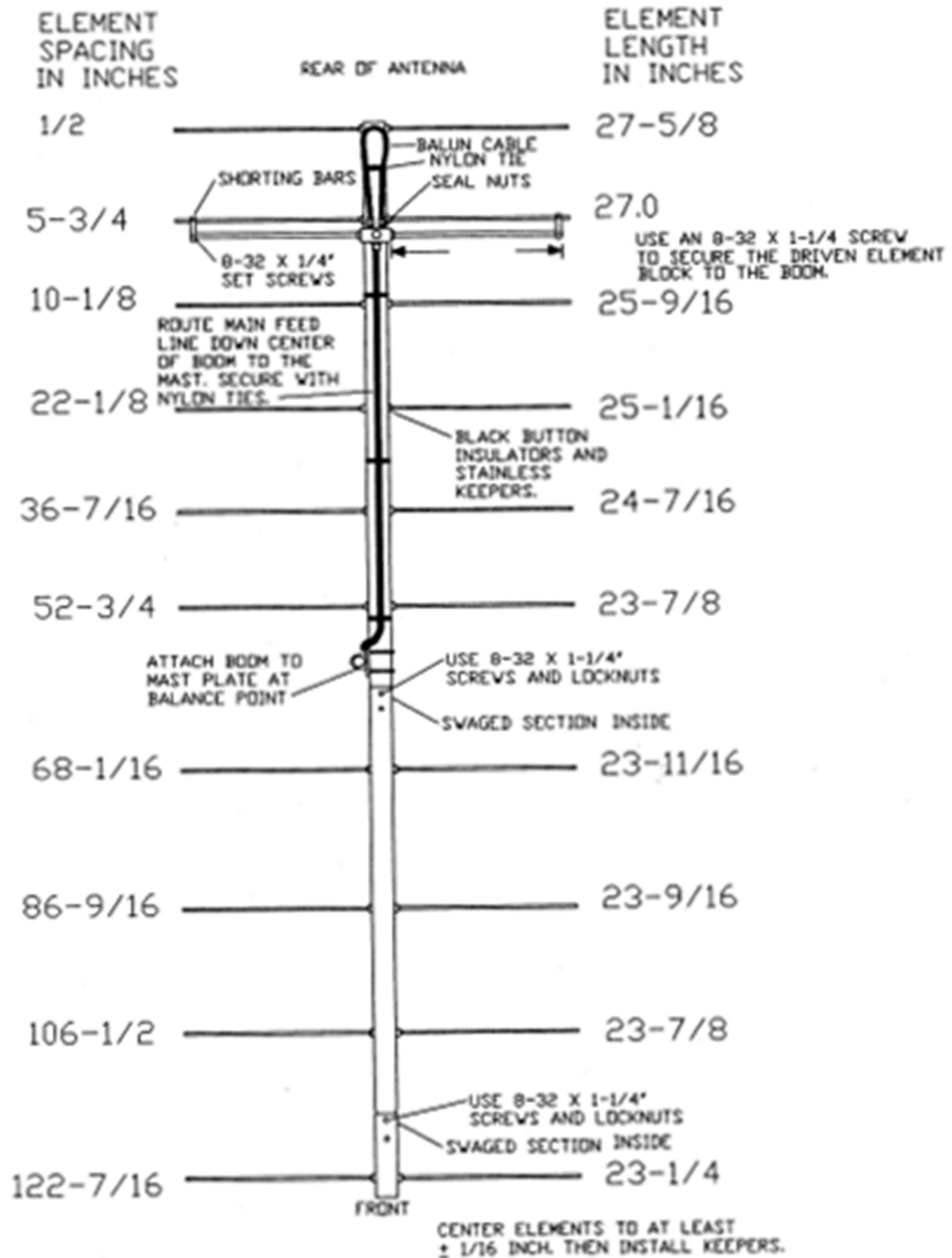

# 213-10 PARTS & HARDWARE

DESCRIPTION	QTY
BOOM SECTION, 1 X .058 X 60" SOE .....	1
BOOM SECTION, 1 X .058 X 60" STR.....	1
ELEMENTS, 3/16 ROD x Dimension Sheet .....	10
DRIVEN ELEMENT ASSEMBLY (SADEA2MVHF1) .....	1
BALUN, RG-6 1/2 WAVE .....	1
BOOM-TO-MAST PLATE, .188 X 3 X 4" (M2APT0019)....	1
U-BOLT AND CRADLE, 2" .....	2
U-BOLT , 1" .....	2
ASSEMBLY MANUAL .....	1

## IN HARDWARE BAG:

SHORTING BAR .....	2
BUTTON INSULATORS .....	20
SHAFT RETAINER, SS.....	20
NUT, 5/16-18 SS .....	4
LOCKWASHER, 5/16 SS .....	4
LOCKNUT, 1/4-20 SS .....	4
SCREW, 8-32 X 1-1/4, SS.....	3
SETSCREW, 8-32 X 1/4 SS.....	4
LOCKNUT, 8-32 SS .....	2
CABLE TIE, NYLON .....	3
ALLEN HEAD WRENCH, 5/64" .....	1
PUSH TUBE, 3/8 X 3" .....	1

## M<sup>2</sup> ANTENNA SYSTEMS, INC.

4402 N. Selland Ave.

Fresno, CA 93722

(559) 432-8873 Fax: (559) 432-3059

[www.m2inc.com](http://www.m2inc.com) Email: [sales@m2inc.com](mailto:sales@m2inc.com)