

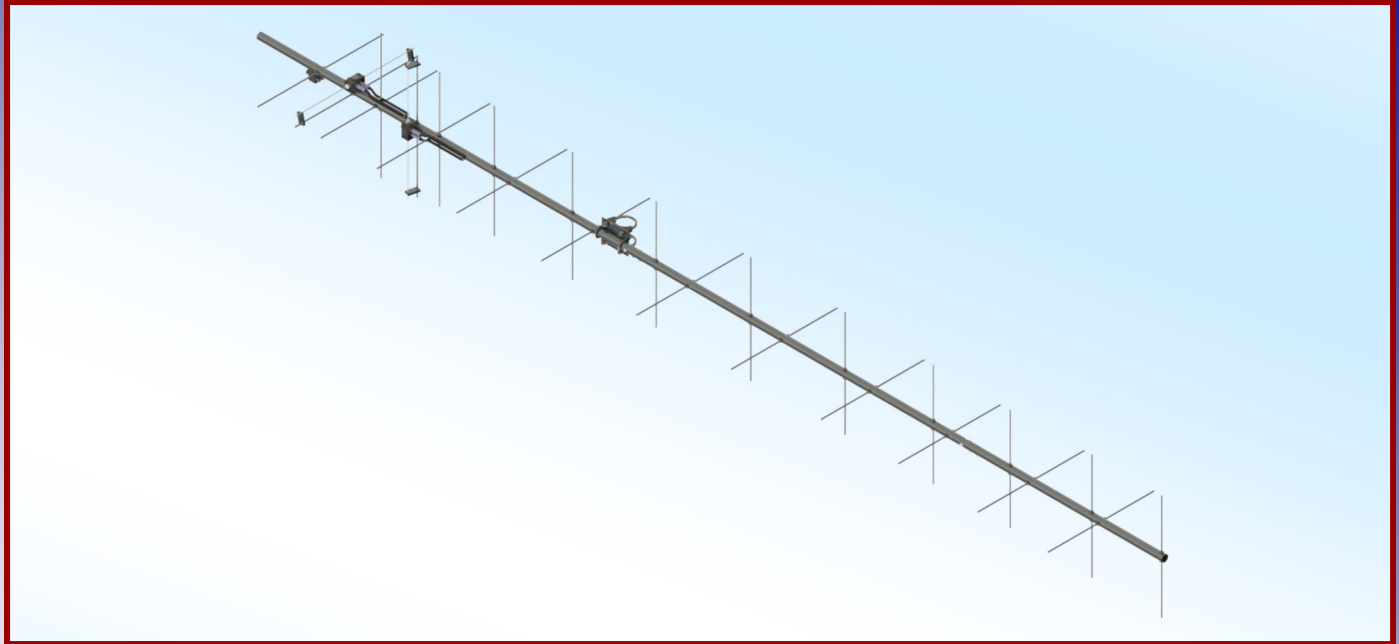

M2 Antenna Systems, Inc. Model No: 350CP24



SPECIFICATIONS:

Model	350CP24	Power Handling	1.5 kW
Frequency Range.....	345 To 365 mHz	Boom Length / Dia.....	96" / 1"
*Gain	14.18 dBi	Maximum Element Length.....	3/16"
Front to back	15 dB Typical	Turning Radius:	Call
Feed type	"T" Match	Stacking Distance.....	Call
Feed Impedance.....	50 Ohms Unbalanced	Mast Size.....	1-1/2" to 2" Nom.
Maximum VSWR.....	1.5:1	Wind area / Survival	1.0 Sq. Ft. / 100MPH
Input Connector.....	"N" Female	Weight / Ship Wt.....	7 Lbs. / 9 Lbs.

***Subtract 2.14 from dBi for dBd**

FEATURES:

The 350CP24 is high performance circular polarized antenna with a remarkably clean pattern. The pattern is important in order to match the antenna's noise temperature with modern low noise preamps. This antenna is ideal for satellite work but is also excellent for terrestrial uses when a circular pattern is desired. The 350CP24 is shown fixed in RHCP but can be ordered with or without a polarity switch.

The CNC machined driven element module is O-ring sealed and weather tight for low maintenance and long-term peak performance. Internal connections are encapsulated in a space-age silicone gel that seals out moisture and improves power handling. The 3/16" 6061-T6 rod elements are centered to minimize interaction and maintain good ellipticity. Insulators are UV stabilized and locked in place with stainless keepers. Rugged construction, uncompromising performance for the boom length: that's the M² 350CP24 !

350CP24 ASSEMBLY MANUAL

TOOL REQUIRED FOR ASSEMBLY: Screwdriver, 11/32 nut driver or wrench, 7/16" and 1/2" socket or end wrenches, measuring tape.

1. Assemble the boom using 8-32 X 1-1/4 screws and locknuts to join sections. Sections may be swaged to each other or use 7/8" internal splice sections.

ASSEMBLING THE HORIZONTAL ELEMENTS

2. Lay out the elements by "H" length and position as shown the DIMENSION SHEET. Start with the reflector (longest) element. Balance it on your finger to find rough center and push on a black button insulator to about 1/2" off center. Push the element through the holes 1/2" from the rear of the boom and install the second button, snugging it up into boom. **DO NOT BOTHER CENTERING** the element at this time and **DO NOT INSTALL** the stainless steel shaft retainers yet. It is easier to do it after all the horizontal elements are installed in the boom.
3. Install the short 6" x 3/16" rod DRIVEN ELEMENT as you did the reflector. Then continue with the installation of the DIRECTORS. **Note that the Director Elements do not consistently diminish in length from rear to front, so pay close attention to length and position.**
4. Now begin centering the elements. Use a tape measure to EQUALIZE, within 1/32", the amount the element sticking out on each side of the boom. Once you have all the elements centered, sight down the element tips from the rear comparing each side. Correct any obvious misalignments.
5. Stainless steel SHAFT RETAINERS lock the elements in place. They should always be used for permanent and long term antenna installations. For portable or temporary use, the button insulators are adequate for holding the elements and the retainers may be left off.

To install the stainless steel SHAFT RETAINERS, use thumb and forefinger to hold the retainer over the end of the PUSH TUBE (3/8" x 3" tube, supplied in the kit), internal fingers on retainer dished into tube. **HOLD THE ELEMENT FIRMLY TO PREVENT IT FROM SLIDING OFF CENTER** and press the retainer onto the element end and continue until retainer butts on insulator button. Locking pliers, **lightly** clamped up against opposite button insulator will help maintain center reference (if you push the first retainer too far, remove element from boom, push retainer completely off the element, and start over). Install another retainer to the opposite side of the element. Continue installing retainers until all elements are secured.

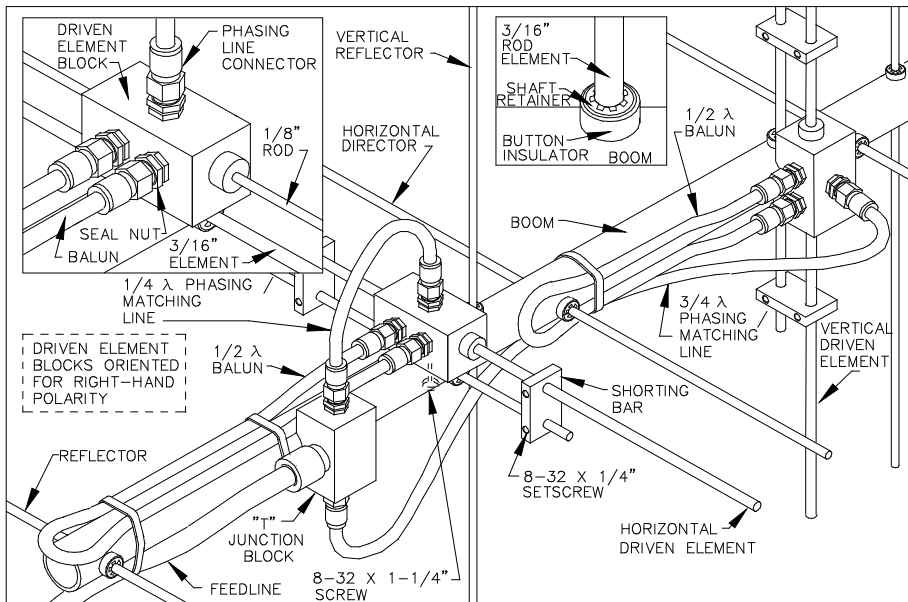
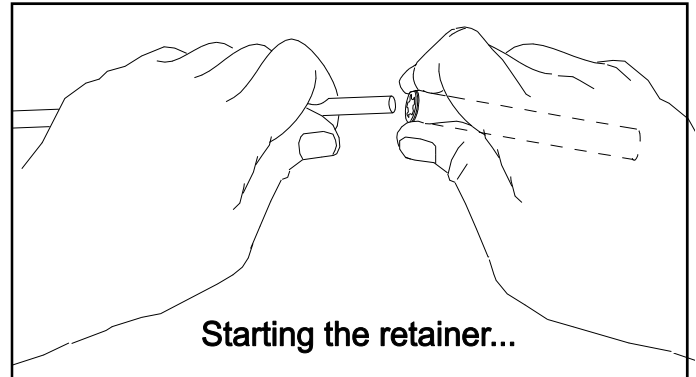

6. Mount the **HORIZONTAL DRIVEN ELEMENT BLOCK / ROD ASSEMBLY** to the **TOP** of the boom using a single 8-32 X 1-1/4" screw. Orient the block with the two balun connectors facing to rear.

7. Install the 8-32 x 1/4" set screws (internal Allen head - tool supplied) into the **SHORTING BARS**. Slide the bars onto the 1/4" Driven Element Block Rods and the 3/16" driven element rod. Position the Shorting Bars as shown on the Dimension Sheet, with the given dimension between the outer face of the driven element block and the inner face of the shorting bar. Align the bars with each other and tighten the set screws.

350CP24 ASSEMBLY MANUAL

ASSEMBLING THE VERTICAL ELEMENTS

8. Repeat steps #2 through #5 to install the Vertical elements, using the Dimension Sheet as your guide to lengths and spacing. Note: The vertical element set is shifted forward on the boom by 1/4 wavelength. This increases isolation between element planes, improving circularity and ease of phasing / matching the two element sets.
9. **INSTALLATION OF THE VERTICAL DRIVEN ELEMENT BLOCK DETERMINES THE CIRCULARITY OF THIS ANTENNA. THE ORIENTATION OF THE BLOCK FOR RHC - RIGHT HAND CIRCULARITY, IS SHOWN ON THE DIMENSION SHEET AND DRAWING AND DESCRIBED BELOW:**
Viewed from the rear of the boom (rearmost Reflector HORIZONTAL), the VERTICAL Driven Element Block mounts to the RIGHT hand side of the boom with the two Balun connectors oriented to the REAR. Secure with 8-32 x 1-1/4" screw. Install the Shorting Bars as in step #7.
10. Install JUNCTION BLOCK to boom with 8-32 x 1-1/4" screw. Depending on model, orientation of block may vary from drawing - see Dimension Sheet for exact placement. Before installing the Baluns and Matching / Phasing Harness, thread 3/8" SEAL NUTS fully onto all connectors, with the black Neoprene side facing out. Attach Baluns and Phasing lines to the Driven Element Blocks and Junction Block as shown on the Dwg. Tighten the connectors **gently** using a 7/16" end wrench. Once the connectors are tight, back the Seal Nuts out and finger-tighten firmly up against the face of the connectors (or tighten **gently** with 1/2" end wrench). A lot of torque is unnecessary. Depending on model and polarity, the Vertical balun may loop around another element. This is normal. Form balun coax until it is close to the boom and secure with a nylon cable tie. Also secure the other balun and the matching / phasing harness coax with cable ties. Ties should be snug but not crushing or kinking the coax.
11. Use good quality coax and "N" connector for your feedline (see Installation Tips). Secure feed coax near connector on Junction Block, to provide stress relief. Allow coax to hang in a loop between the rear end of the boom and the reattachment point (at least 12" beyond element tips) on the mast or crossboom. **Do not route feedline to boom to mast plate as exiting antenna here will adversely affect circular field.**
12. The boom to mast plate is normally mounted to the boom at the balance point. Since the feed line represents significant weight it is best to have it attached and fastened to the boom with cable ties before final mounting the plate. Use two 1" U-bolts and the stainless nuts and lock washers provided. DO NOT OVER TIGHTEN. 1-1/2" and 2" U-bolts (and stainless steel nuts / lockwashers) are provided for mounting the antenna to your NON-CONDUCTIVE mast or crossboom.

INSTALLATION TIPS

13. A circular polarized antenna creates fields in all planes or polarities. Performance DETERIORATES SIGNIFICANTLY if it is mounted on a metal (conductive) mast or crossboom. A mast or crossboom of any NON-CONDUCTIVE material can be used. Fiberglass is the prime choice for its strength and weather resistance. Mount the antenna so that element tips are at least 12" from any conductive material (mast, tower, feedline, etc.).
14. Try to keep the cable run to under 100 ft. to prevent excessive signal loss.
Recommended feedlines, in order of preference:
Andrews or Celwave 1/2" hardline
Times LMR400 or Belden 8214
15. To maintain proper phasing when stacking two or more antennas, mount each with the same orientation of Driven Element Blocks. DO NOT MOUNT IN MIRROR IMAGE. See the Specification Sheet for stacking distances. For more detailed stacking information contact M².

350CP24 PARTS LIST

350CP24 PARTS LIST

8-16-93
6-28-95

DESCRIPTION	QTY.
Boom section, 1 x .058 x 55" PLAIN	1
Boom section, 1 x .058 x 44-1/2" SOE	1
Boom to mast plate, 3 x 4 x .125"	1
Elements, 3/16" alum. rod x (see dims.)	24
Driven element block assembly,	2
Junction Block assembly	1
Balun, RG-6U halfwave length	2
Phasing line, RG6-U quarterwave length	1
Phasing line, RG6-U three quarterwave length	1
U-bolt and cradle, 2"	2
U-bolt and cradle, 1-1/2"	2
U-bolt, 1" no cradle	2
Assembly instructions	1
IN HARDWARE BAG	
Shorting bars, .75 x 1.532 x .250" mach. alum.	4
Button insulators, 3/16" black	48
Shaft Retainers, 3/16" ss	48
Nut, 5/16-18 ss	4
Lockwasher, 5/16" ss	4
Screw, 8-32 x 1-1/4" panhead	5
Set screw, 8-32 x 1/4" ss	8
Locknut, 8-32 ss	2
Nuts, 1/4-20 ss	4
Lockwasher, 1/4-20 ss	4
Seal nuts, 3/8-32 gold zinc	8
Allen wrench, 5/64"	1
Push tube, 3/8 x 3" (for keeper installation).....	1
Cable ties, 8"	4

Carefully Manufactured by M2 Antenna Systems, Inc.
4402 N. Seland Ave.
Fresno, CA 93722
559-432-8873 Fax 559-432-3059
Www.m2inc.com / email: sales@m2inc.com