

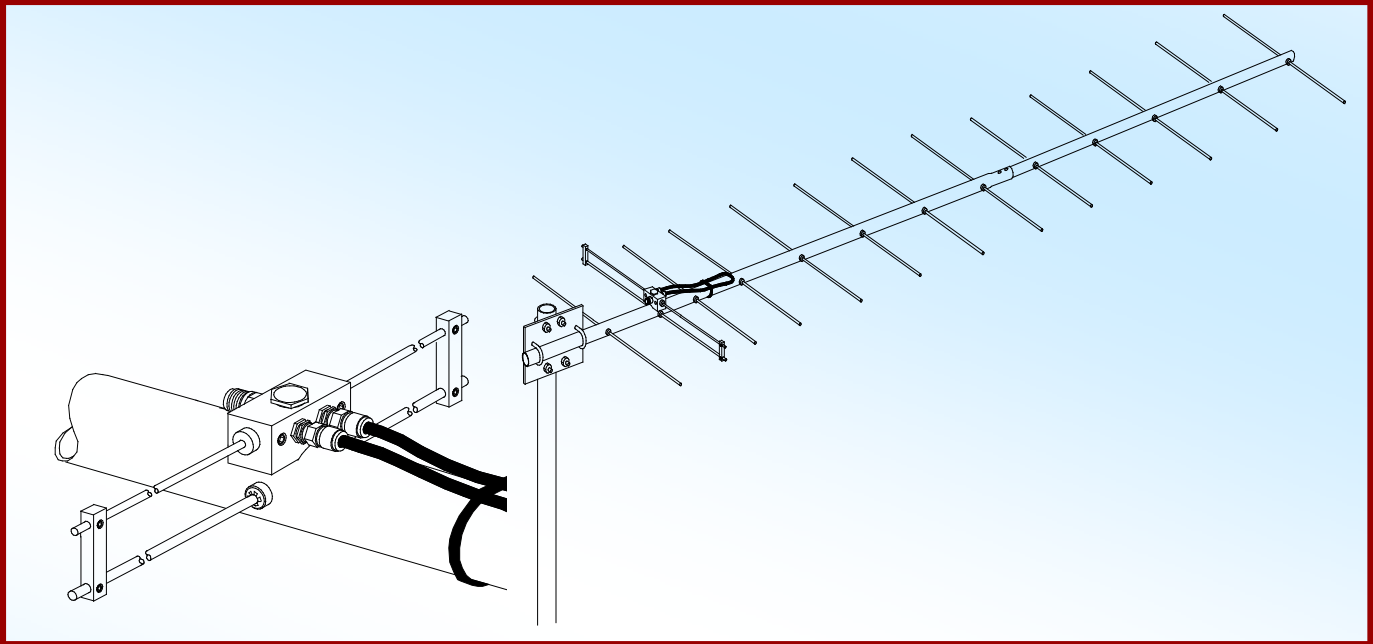

M2 Antenna Systems, Inc. Model No: 510-13 (TV CHANNEL 20-13)



SPECIFICATIONS:

Model	510-13 (CH20-13)	Power Handling	1.5 kW
Frequency Range.....	500-515 MHz	Boom Length / Dia.....	78" / 1" - 3/4"
*Gain	15.8 dBi	Stacking Distance.....	E=42" / H=41"
Front to back	22 dB Typical	Mounting.....	1-1/2" to 2" Nom.
Beamwidth	E=30° / H=34°	Wind area / Survival	1.0 Sq. Ft. / 100 MPH
Feed type	"T" Match	Weight / Ship Wt.....	5 Lbs. / 6 Lbs.
Feed Impedance.....	50 Ohms Unbalanced		
Maximum VSWR.....	1.5:1		
Input Connector.....	"N" Female		

***Subtract 2.14 from dBi for dBd**

FEATURES:

The 510-13 (CH20-13) has been computer designed to cover the entire channel 20 bandwidth plus extra bandwidth on the high side to account for weather effects. The clean pattern provides more reliable signals with less interference. An optional stacking harness is available when more than one antenna is required for reduced beamwidth or additional gain. Users are surprised by the performance of this compact but potent antenna.

Construction is classic M2 for long term electrical and mechanical integrity. Elements are 3/16" 6061-T6 rod, mounted through the boom on UV stabilized insulators and locked in place with stainless steel shaft retainers. The driven element module is CNC machined and all connectors are O-ring sealed. Internal connections are encapsulated in a space-age silicone gel with nearly 4 times the dielectric strength of air. Balun connectors are triple-sealed to the coax. Single channel models can be manufactured for all television and FM applications.

510-13 (CH20-13) ASSEMBLY MANUAL

Tools handy for assembly process: screwdriver, 11/32" spin-tite or socket, 7/16" and 1/2" end wrenches / sockets, measuring tape.

1. This antenna uses a one-piece boom. A factory installed 7/8" x 24" sleeve provides additional boom strength for rear mounting the antenna. Check that sleeve is in position, flush with rear end of boom and all holes are aligned with boom.
2. Lay out the elements by length and position as shown the DIMENSION sheet. Start with the reflector (longest) element and push on a black button insulator to about 1/2" from center. Push the element through the holes 1/2" from the rear of the boom and install the second button, snugging it up into boom. DO NOT BOTHER WITH ACCURATELY CENTERING the element at this time and DO NOT INSTALL the stainless steel internal locking "KEEPERS" yet. This is easier to do after all the elements are installed in the boom.
3. Install the 3/16" rod DRIVEN ELEMENT as you did the reflector. Then continue with the installation of the DIRECTORS. **Note that the Director Elements do not consistently diminish in length from rear to front, so pay close attention to length and position.**

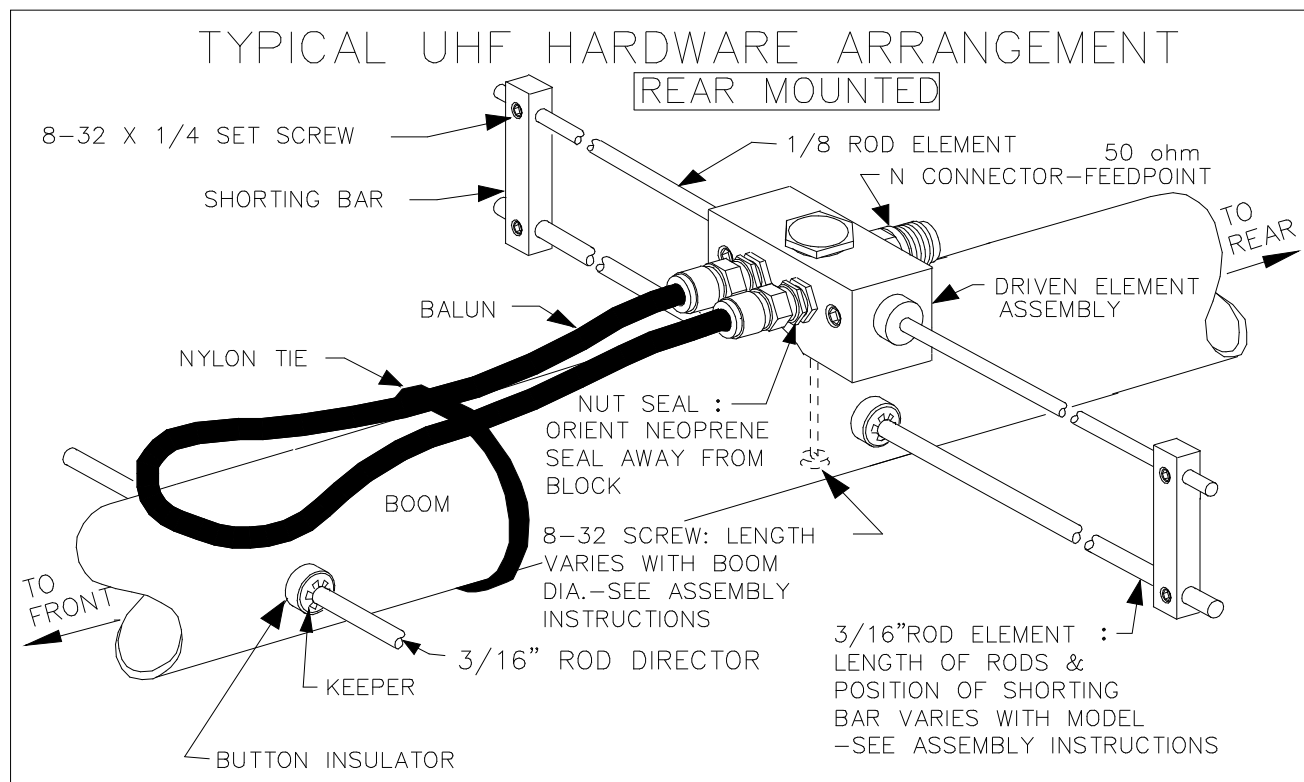

4. Now begin centering the elements. Use a tape measure to EQUALIZE the amount the element sticking out on each side of the boom. Once you have all the elements centered, sight down the element tips from the rear comparing each side. Look for any obvious discrepancies and correct if found.
5. Install the stainless steel SHAFT RETAINERS to secure the elements. NOTE: For portable or temporary use of the antenna, the retainers may be left off. The button insulators, normally a tight fit, hold the elements quite securely.
To install, use thumb and forefinger to hold the retainer over the end of the PUSH TUBE (3/8" x 3" tube, supplied in the kit), internal fingers on retainer dished into tube. HOLD THE ELEMENT

510-13 (CH20-13) DIMENSION SHEET

CHAN20-13 DIMENSION SHEET

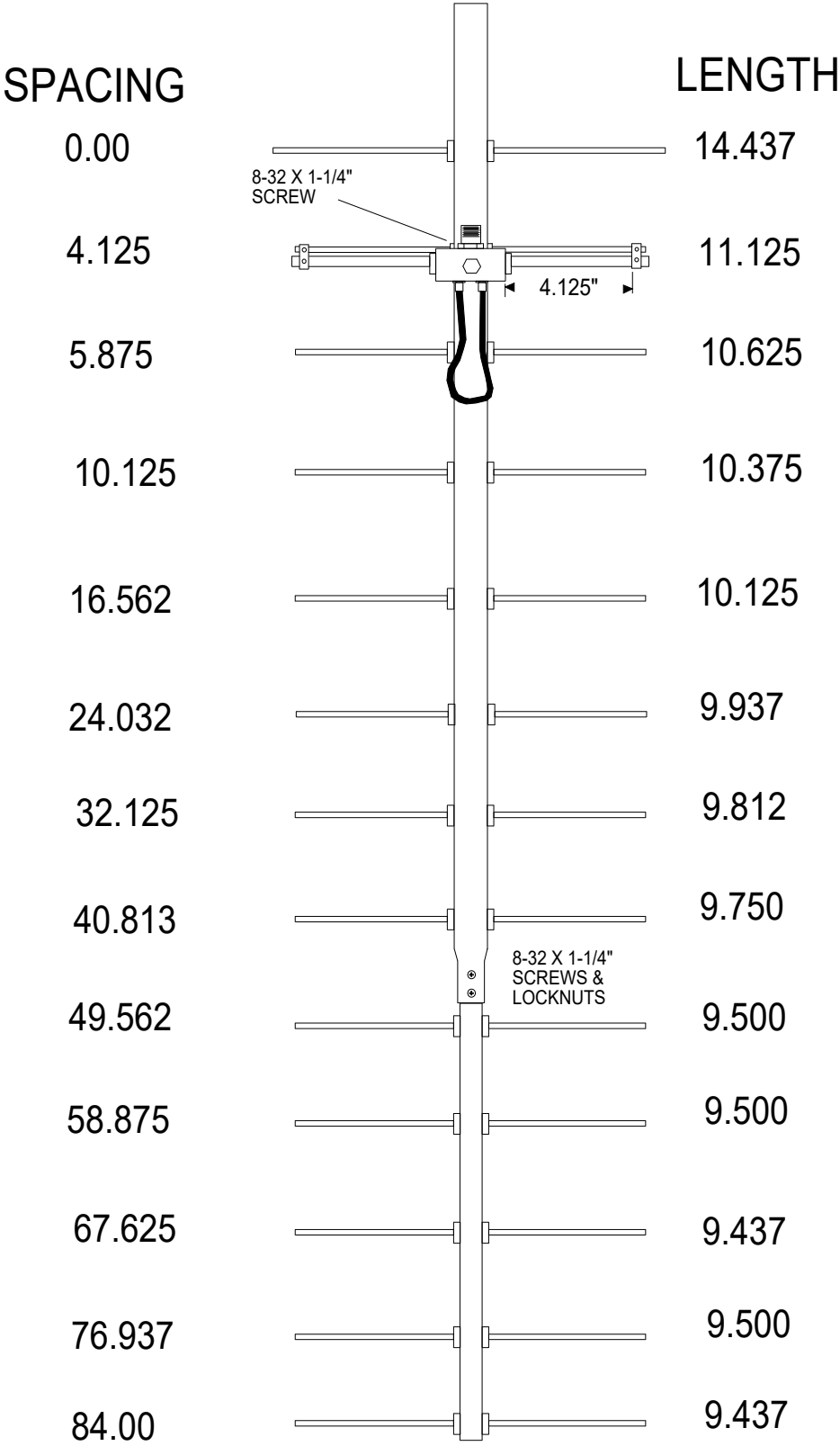

510-13 (CH20-13) MANUAL CONTINUED

FIRMLY TO PREVENT IT FROM SLIDING OFF CENTER and press the retainer onto the element end and continue until retainer butts on insulator button. Locking pliers, *lightly* clamped up against opposite button insulator will help maintain center reference. If you push the first retainer too far, remove element from boom, push retainer completely off the element, and start over. Install another retainer to the opposite side of the element. Continue installing retainers until all elements are locked in place.

6. Mount the DRIVEN ELEMENT BLOCK to the boom using a single 8-32 X 1-1/4" screw and lockwasher. Orient the block with type "N" feed connector facing to the rear and balun connectors facing to the front. Block orientation may be reversed if you wish to center mount antenna.
7. Before installing the balun, thread a 3/8" SEAL NUT all the way onto each connector, with the black Neoprene face of the nuts facing out. Attach balun and tighten the connectors *gently* using a 7/16" end wrench. Once the connectors are tight, back the Seal Nuts out and finger-tighten firmly up against the face of the connectors (or tighten *gently* with 1/2" end wrench). A lot of torque is unnecessary. Form the balun close to the boom and secure to boom with a nylon cable tie. Tie should be snug but not crushing or kinking the coax.
8. Install the 8-32 x 1/4" set screws (internal Allen head - tool supplied) into the SHORTING BARS. Slide the bars onto the 3/16" rod driven element tips and 1/8" Driven Element Block Rods. Position the Shorting Bars as specified on the Dimension Sheet: the distance given is between the outer edge of the Driven Element Block and the inner edge of the Shorting Bar. Align the bars and rods with each other and tighten the setscrews.
9. The boom to mast plate is normally mounted at the rear of the boom using 1" U-bolts and the stainless locknuts provided. DO NOT OVER TIGHTEN. 2" U-bolts, cradles, and stainless hardware are provided for mounting the antenna to your mast. Secure feed coax to boom and mast with harness ties.

10. MOUNTING

THIS ANTENNA CAN BE **REAR MOUNTED** IN ANY POLARITY TO ANY TYPE OF 2" MAST.

IF YOU PLAN TO CENTER-MOUNT THE ANTENNA PLEASE FOLLOW THE GUIDELINES BELOW:

Maintain good VSWR and pattern: Keep metallic masts, crossbooms and the feed coax out of the element plane.

FOR HORIZONTAL POLARIZATION, the antenna may be center-mounted to a metallic vertical mast or a horizontal NON-METALLIC crossboom (no conductive material in element plane). If mounted to a horizontal crossboom, route the feedline forward to the boom-to-mast plate, loop down at right angles to the element plane, and bring back to crossboom at least 6" beyond element tips.

FOR VERTICAL POLARIZATION, the antenna may be center-mounted to a NON METALLIC VERTICAL MAST (no conductive material in element plane) or a horizontal metallic crossboom. If mounted to a vertical mast, route the feed line forward to the boom-to-mast plate, loop out at a right angle to the boom, and bring down to the mast at least 6 inches BELOW THE ELEMENT TIPS. The feedline may also exit at the rear of the boom and loop back to the mast.

Stacking? Call **M²** and let us help you DO IT RIGHT

THIS COMPLETES THE ANTENNA ASSEMBLY.

510-13 (CH20-13) PARTS LIST

PARTS LIST

10-12-05

DESCRIPTION	QTY
BOOM SECTION, 1 X .058 X 60" SOE	1
BOOM SECTION, 3/4" X .049 X 43"	1
SLEEVE, 7/8 X .058 X 24" (factory installed)	1
ELEMENTS, 3/16 ROD x Dimension Sheet	13
DRIVEN ELEMENT BLOCK	1
BALUN, RG-6 1/2 WAVE	1
BOOM-TO-MAST PLATE, .188 X 3" X 4"	1
U-BOLT AND CRADLE, 2"	2
U-BOLT, 1"	2
ASSEMBLY MANUAL	1

IN HARDWARE BAG:

SHORTING BAR	2
BUTTON INSULATORS	26
KEEPER, SS	26
NUT, 5/16-18 SS	4
LOCKWASHER, 5/16 SS	4
LOCKNUT, 1/4-20 SS	4
SETSCREW, 8-32 X 1/4, SS	4
SCREW, 8-32 X 1-1/4 SS	3
LOCKNUT, 8-32, SS	2
LOCKWASHER, #8 SS	1
CABLE TIE, NYLON	3
SEAL NUTS, 3/8-32	2
ALLEN HEAD WRENCH, 5/64"	1
PUSH TUBE, 3/8 X 3"	1

MADE IN THE U.S.A.
M² ANTENNA SYSTEMS, INC.
4402 N. SELLAND AVE. FRESNO, CA 93722
559-432-8873 FAX 559-432-3059
www.m2inc.com sales@m2inc.com