

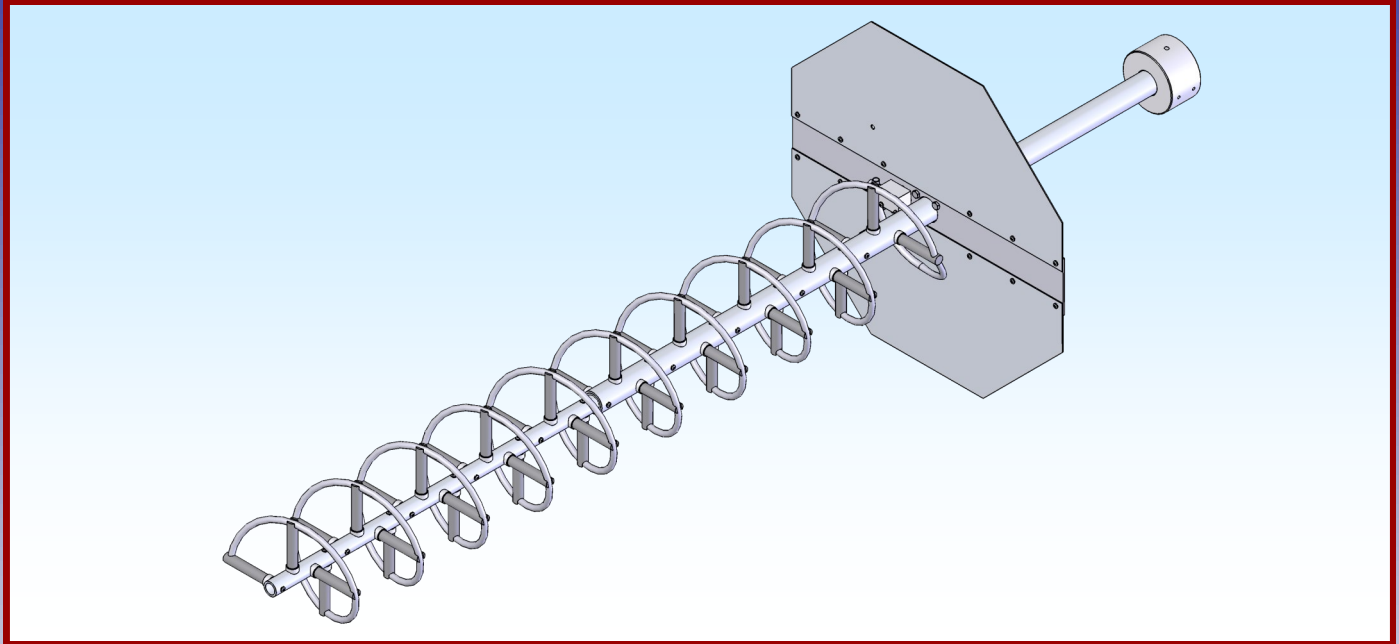

# M2 Antenna Systems, Inc.

## Model No: 500-1000-10



### SPECIFICATIONS:

Model .....	500-1000-10	Input Connector .....	"N" Female
Frequency Range .....	390 To 650 MHz	Power Handling .....	1 kW
*Gain .....	12 To 13 dBic	Polarity.....	RHCP or LHCP
Front to back .....	20 dB Nominal	Mounting .....	Adjustable AZ-EL on 2"
Beamwidth .....	46° Nominal	Operating Temperature .....	-50 F To 130 F
Feed Impedance .....	50 Ohms	Wind area / Survival .....	100 MPH
Maximum VSWR.....	1.5:1	Weight / Ship Wt.....	20 Lbs./ 80Lbs.
Input Connector.....	"N" Female	Length.....	52"
Power Handling.....	1 kW	Helical dia .....	5.1"

**\*Subtract 2.14 from dBic for dBdc**

### FEATURES:

The M2 500-1000-10 Helix antenna model is designed to meet environmental condition specified by MIL-STD-810 and offers performance characteristics for specialized fixed and rapid deploy operations within the 500 to 1000 MHz band. It is perfect for either terrestrial or satellite applications. The antenna is supplied with a manually adjustable Azimuth / Elevation mount and a counter weight. The antenna is shipped with the helix assembled less ground plane. The Finish is gold anodyne plating. The steel adjustable mounting fixture and counterweight are zinc plated. Optional tactical carrying cases are available. Optional arrays of 2 or more are available. Other frequency ranges and gains are also available down to 100 MHz. Complete motorized, computer controlled AZ-EL systems are also manufactured by M2. Where circular polarity is not required but high bandwidth is, M2 offers a line of various log periodic antennas from 5 to 1300 MHz. If it is antenna related, we probably have made it. Call us with your requirements.

# 400-600-10 HELICAL ASSEMBLY MANUAL

TOOLS REQUIRED: #2 Phillips head screwdriver, 11/32 nut driver and 7/16" socket open end wrench.

1. Unpack the factory assembled HELICAL antenna, the CENTER REFLECTOR PLATE, and the two (2) REFLECTOR HALVES. Attach the Reflector halves to the Center Reflector Plate using 8-32 x 3/4" screws and locknuts.
2. Add the g-plane clamp #1 to the center reflector plate near the center hole using 1/4-20 x 3/4 bolts and lock washers. Then slide the assembly up the rear end of the helix boom. Align the hole in the rear boom section of the helix assembly with that of the g-plane clamp #1 and use a 1/4-20 x 3/4" bolt to set the position of the ground plane by threading the bolt through the g-plane clamp #1 and into the boom. This sets the position of the ground plane. Then add the g-plane clamp #2 and secure using 1/4-20 x 2 1/2 bolts and locknuts.
3. Slide the feed support block on to the helix, note that the hole in the support block is off set, install the block so there is the greatest distance between the helix and the ground plane. Align the holes on the ground plain and leave loose at this point. Then slide the 'N'-connector block assembly on the helix and rotate the connector down through the large hole in the plate. Secure the block to the plate with four (4) 8-32 x 1-1/2" screws and locknuts. Add the 1/4-20 bolt through the feed block support and ground plane and secure. Now install the 1/4-20 x 1/4" set screw in the round end of the feed block assembly and tighten, using the supplied 1/8" Allen wrench. Note set screw markings from original test assembly. Helix should protrude no more than 1/8" past the feed post. This completes the assembly.

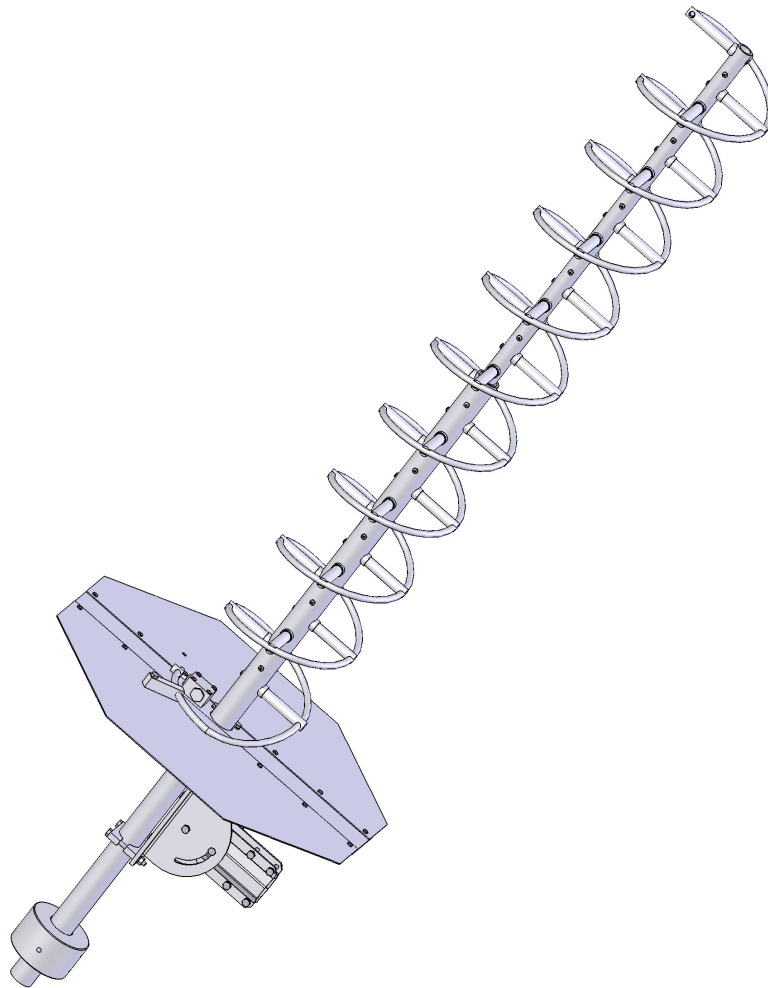

# 400-600-10 FEED ASSEMBLY DETAIL

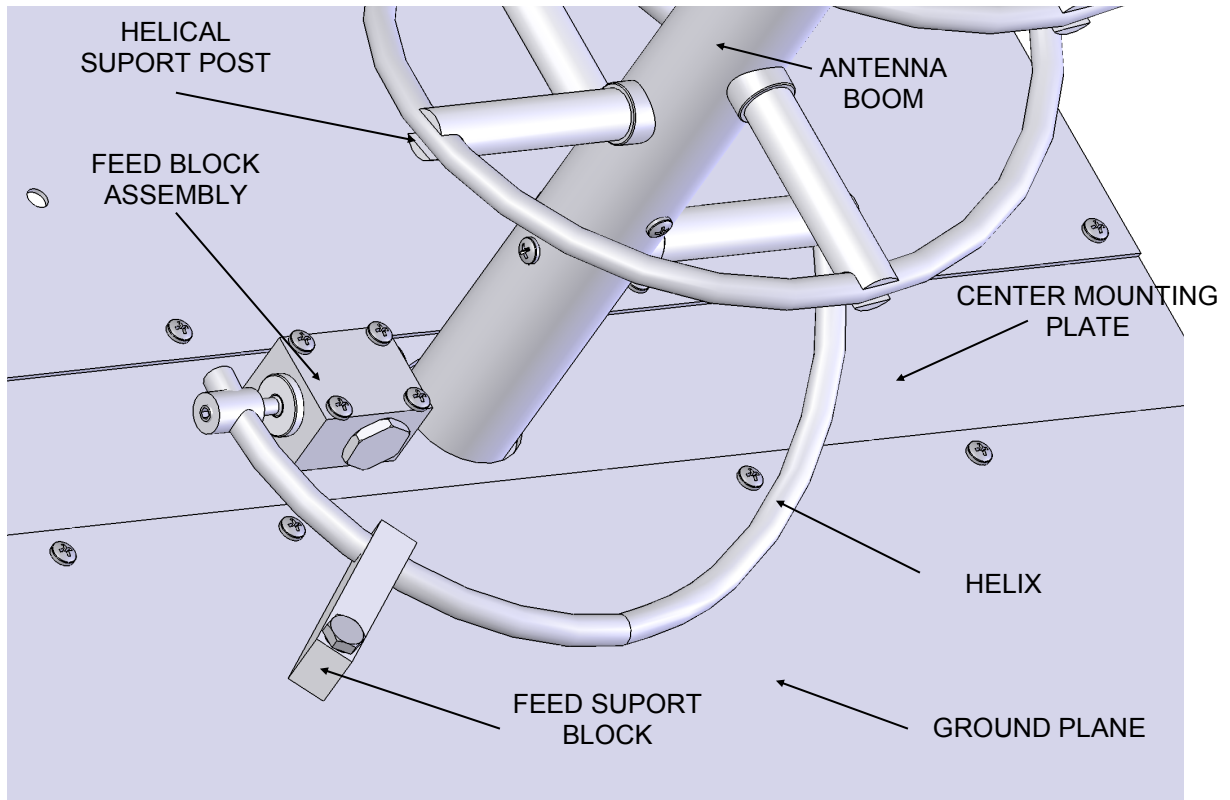

# 400-600-10 GROUND PLANE DETAIL

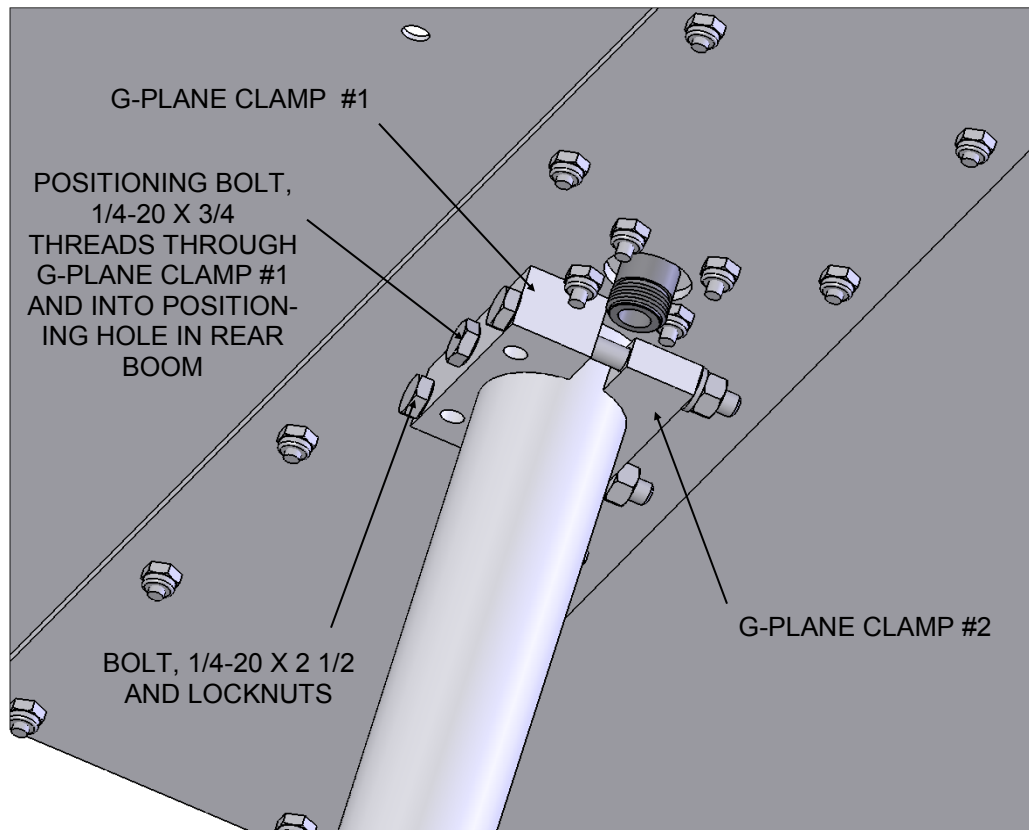

# OPTIONAL ELEVATION MOUNTING

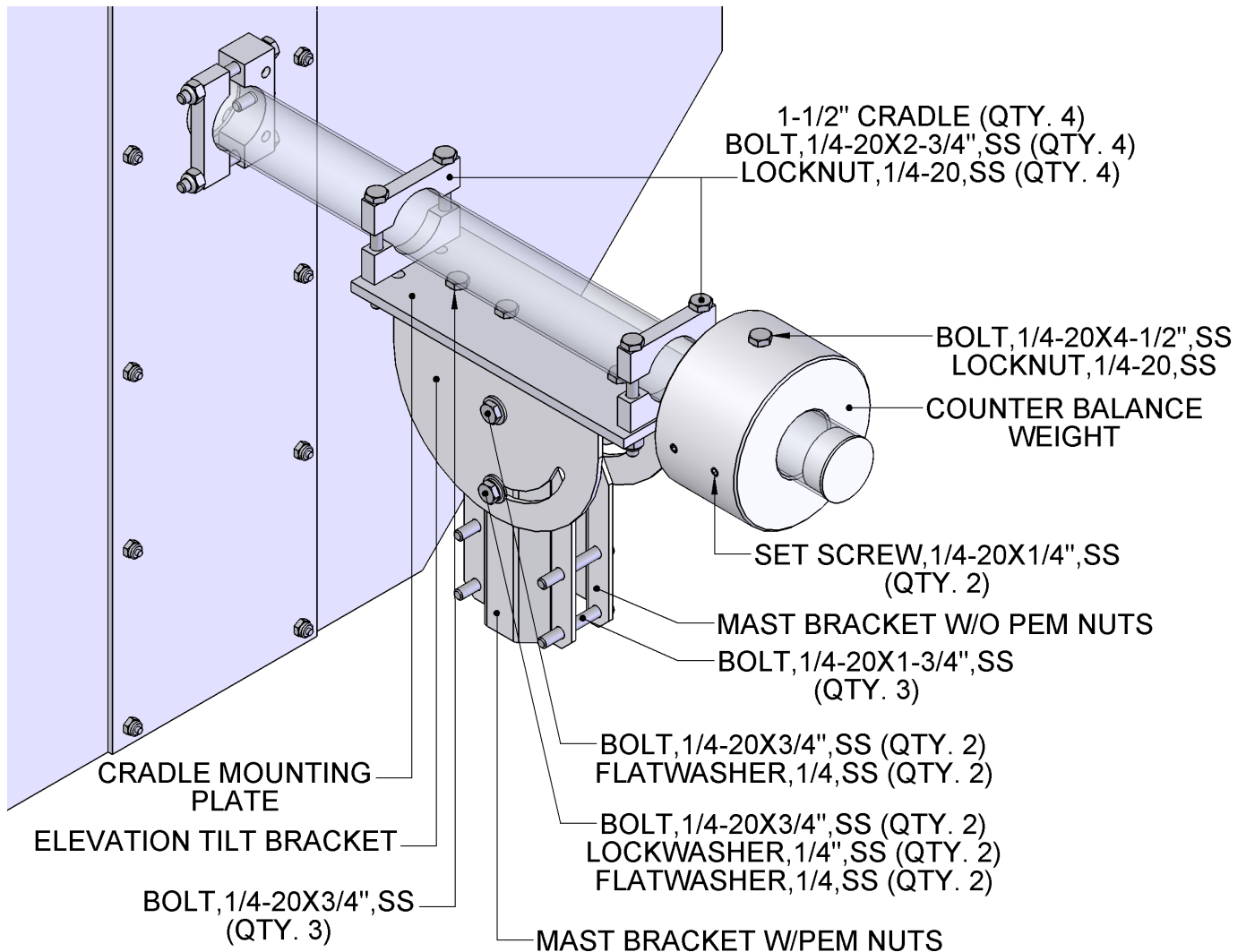

4. Assemble the Elevation Bracket hardware as shown on the assembly picture. For the time being set the elevation angle to 0 deg. (mast bracket perpendicular to the antenna). Attach the 1.5" saddle adapter plate to the elevation bracket. Next, using four 1/4-20 x 2 3/4" bolts and locknuts, attach the four saddles loosely to the saddle adapter plate. Now slide the entire assembly onto the back of the boom, position right up against the mounting plate collar, and set the feed connector to the desired rotational orientation. Tighten the four saddle bolts.

5. With an associate, slide the antenna onto the top of a 2" support pole. Point the antenna to the proper azimuth and elevation angles, and tighten all of 1/4-20 hardware on the mast clamp bracket. Add the optional counter balance weight to the end of the heical, slide the weight to a position that will provide balance to the antenna system, add 1/4-20 set screws to hold the position of counter balance. Drill through the counter balance locking pin hole and secure with a 1/4-20 x 4 1/2 bolt and lock nut.

**This completes the assembly.**

# 400-600-10 PARTS LIST

<u>DESCRIPTION</u>	<u>QTY</u>
HELIX AND MAIN BOOM.....	1
CENTER MOUNTING PLATE, .....	1
REFLECTOR PLATE .....	2
G-PLANE CLAMP 1.5" BM DIA #1 .....	1
G-PLANE CRADLE CLAMP 1.5" BM DIA #2 .....	1
FEED BLOCK W/ "N" CONN.....	1
FEED SUPPORT BLOCK, .50 X .750 X 2.5" .....	1
COUNTER BALANCE WEIGHT.....	1
ASSEMBLY MANUAL .....	1

## HARDWARE BAG

<u>DESCRIPTION</u>	<u>QTY</u>
BOLT, 1/4-20 x 3/4" SS .....	3
BOLT, 1/4-20 X 1 1/4 SS.....	1
BOLT, 1/4-20 X 2.50 SS.....	2
BOLT, 1/4-20 X 4.5 SS.....	1
SET SCREW, 1/4-20 x 1/4" SS .....	3
LOCKNUT, 1/4-20, SS.....	7
SCREW, 8-32 X 1-1/2", SS .....	4
SCREW, 8-32 X 3/4", SS.....	12
LOCKNUT, 8-32 SS .....	16
1/8 ALLEN WRENCH .....	1

## OPTIONAL ELEVATION MOUNT KIT

<u>DESCRIPTION</u>	<u>QTY</u>
SADDLE ADAPTER PLATE .....	1
SADDLES, 1.5" DIA.....	4
ELEVATION BRACKET .....	1
MAST BRACKET (W/ PEM NUTS) .....	1
MAST BRACKET (W/O PEM NUTS).....	1

## HARDWARE BAG

<u>DESCRIPTION</u>	<u>QTY</u>
BOLT, 1/4-20 x 3/4" SS .....	7
BOLT, 1/4-20 x 1-3/4" SS .....	4
BOLT, 1/4-20 X 2-3/4" SS.....	4
FLATWASHER, 1/4", SS .....	4
LOCKWASHER, 1/4 SS .....	4
LOCKNUT, 1/4-20, SS.....	5

## M<sup>2</sup> ANTENNA SYSTEMS, INC.

4402 N. SELLAND AVE.

FRESNO, CA 93722

(559) 432-8873 FAX: 432-3059

www.m2inc.com Email: sales@m2inc.com