

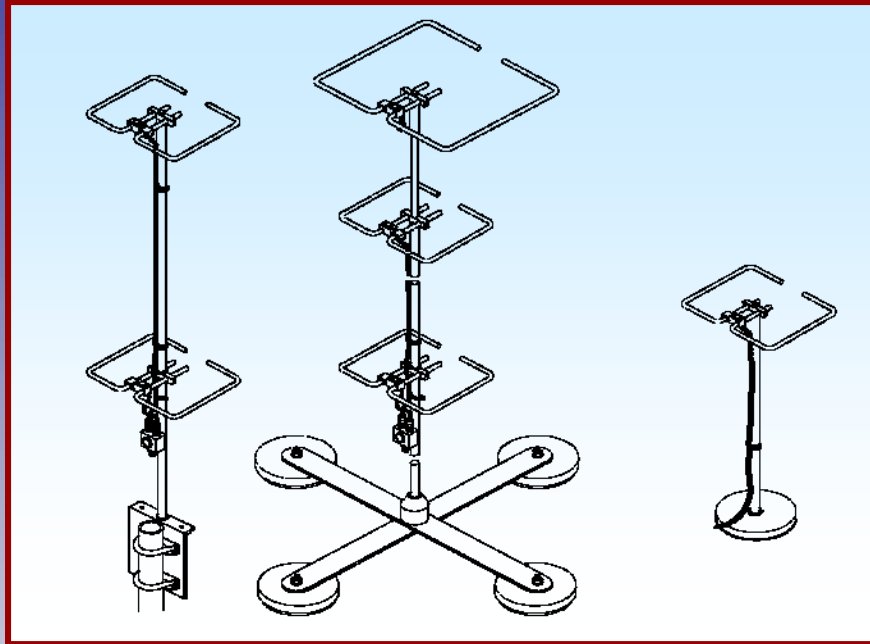

M2 Antenna Systems, Inc. Model No: 222 HO LOOP



SPECIFICATIONS:

Model	222M HO LOOP	Feed Connector.....	SO-239
Frequency Range.....	220 To 224 MHz	Mounting.....	3/8-24
Gain, Typical @ 84"	4.75 dBd @ 7 deg.	Vehicle Mounting Height	18" or more
Gain, 2 Stack @ 84" & 117"	8.2 dBd 7 deg.	Stacking Separation	33" to 36"
Polarity	Horizontal Omni	Wind Area.....	0.02 sq ft.
Impedance	50 Ohms, Unbalanced	Weight	12 oz.
Power Handling.....	800W, 1.5kW for Stack		

***Subtract 2.14 from dBi for dBd**

FEATURES:

The new 222 MHz HO loop provides easy SSB and CW communications out to 200 miles or more. HO LOOPS produces an omnidirectional, HORIZONTALLY polarized signal ideal for mobile and base operations. Horizontal polarity permits the HO loop to pick up 5+dB of ground gain that verticals can't. As with most horizontally polarized antennas, performance improves dramatically with height above ground. By stacking two HO LOOPS, another big gain jump occurs. Physically, the 222 HO loop is a 7.75" square, size loop, fabricated from two 3/8" dia. aluminum tubes to minimize losses. The sealed feed block provides weather protection with minimum wind drag. The heart of this unique design is the shorted stub matching to a 50 ohm coaxial feedline. Mounting is via a single 3/8" hole that is standard for most mobile hardware. For enhanced performance, add a second HO LOOP and STACKING KIT, it has all you need, phasing lines, "T" junction block, upper and lower 1/2 " and 5/8" mast sections. For easy base-station installation use the optional wall / mast mounting bracket and U-bolts. For a powerful mobile signal, stack an array of HO loops on our optional "BIG FOOT", mag-mount (shown above). Use, the optional 5" magnet and 18" mast for single band mobile operation.

222 HO LOOP ASSEMBLY MANUAL

1. Insert the 1/4-20 x 1/4" set screws a few threads into the two connector blocks. Use the 1/8" Allen wrench provided. Insert the 1/4-20 x 1/4" set screws a few threads into the ends of the shorting bar.
2. Refer to the **HO-LOOP** ASSEMBLY SHEET and insert the tubes into the two connector blocks as shown. Slide on the shorting bar, align the loops and GENTLY tighten the 1/4-20 x 1/4" set screw onto the tubes. Be sure the blocks are set to the starting 'A' dimension. The 'A' dimensions controls the FREQUENCY.
3. Set the shorting bar to the 'B' dimension shown and tighten gently. When complete check match and tighten . The 'B' dimension controls the MATCH
4. Once the loop is assembled either final tune it in its final position on your vehicle or if tower mounted, simulate the mast size and other conditions to minimize final tuning in position.
4. That is about it. A 3/8-24 x 1" bolt and washer is provided to attach the **HO LOOP** to any standard mobile mast or any M2 mast available as an option.

REMEMBER, HORIZONTALLY POLARIZED ANTENNAS ARE AFFECTED BY THE GROUND SO THE HIGHER YOU AND GET YOUR HOOP LOOP THE BETTER. The ground can be your friend as well providing as much as 6 dB additional ground gain at some angle above the horizon. That angle is defined by the frequency and height above ground. At one wavelength, 80" at two meters, the typical angle of maximum radiation will be about 14 degrees. At two wavelengths, the angle is 7 degrees and at 4 wavelengths (27 ft.), the angle is 3.5 degrees. Net gain improves with height because the pattern hits the ground at a more grazing angle giving up less energy to the ground.

In most mobile installations 10 to 11 feet is about the practical limit for most driving conditions. The HO LOOP works at just 18" above a vehicle roof and contacts out 200 miles are quite common. However you will find more people to talk to and longer if you can get the **HO LOOP** up at the 10 foot level.

POWER CONSIDERATIONS : 10 Watts into the HO LOOP will do well out to about 80 miles. 150 Watts gets you into that 200 mile category and 350 to 400 Watts get to the 300-400 and you will enjoy much longer QSO's on a regular basis. From a hill top location 600-800 mile QSO's have been reported several times. We hope you enjoy your new **HO LOOP** and please keep an ear out for those rare but wonderful skip openings to other parts of the country!

Contact M2 for optional items available for your **HO LOOP**!

M² ANTENNA SYSTEMS, INC.

4402 N. Selland Ave.

Fresno, CA 93722

(559) 432-8873 Fax: 432-3059

www.m2inc.com Email: sales@m2inc.com

222 HO LOOP ASSEMBLY MANUAL

FINAL TUNE HO LOOP IN MOUNTED POSITION.

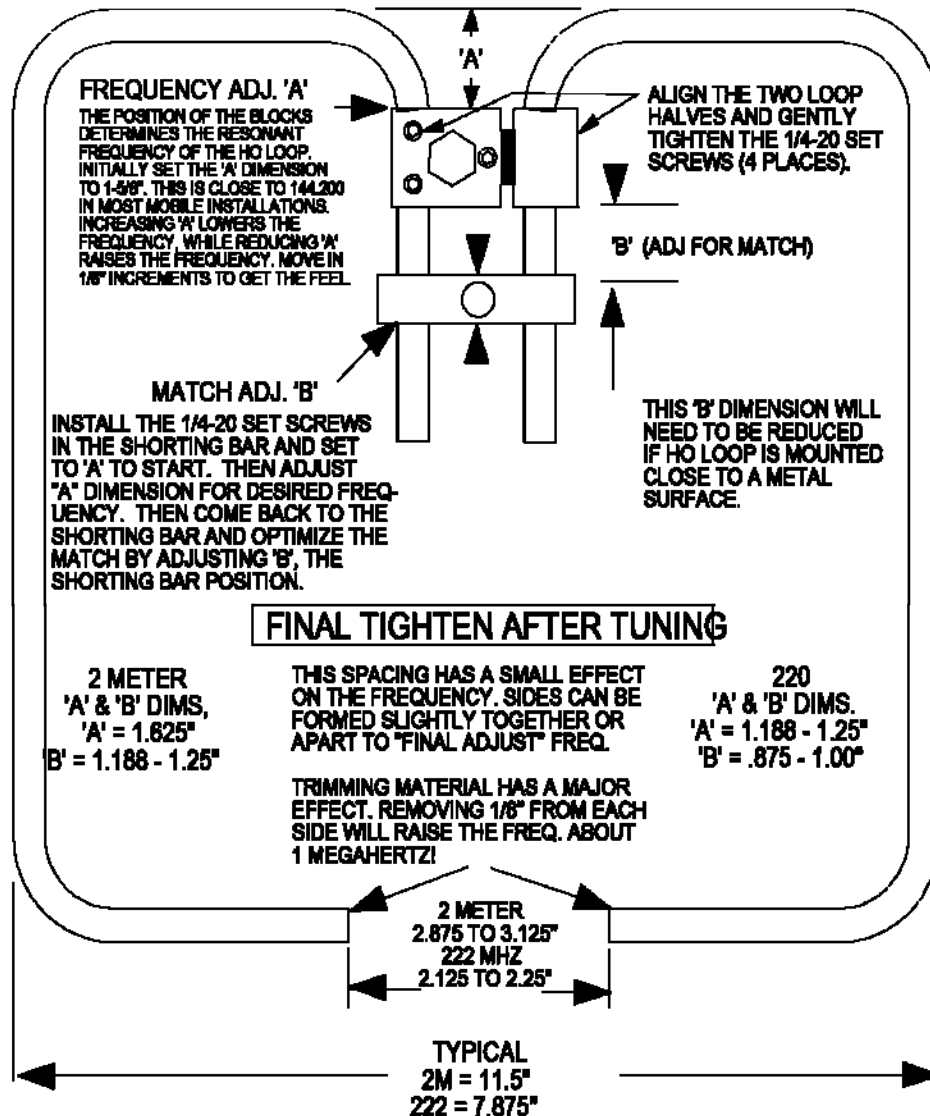

MAST MOUNTING

IF THE HO LOOP IS MAST MOUNTED AS SHOWN, THE RESONANT FREQUENCY WILL GO UP ABOUT 800 KHZ. INCREASE DIMENSION 'A' TO 1-3/4 TO 2" TO BRING RESONANCE BACK TO JUST ABOVE 144.200 MHZ. ADJUST FOR BEST MATCH AFTER GETTING THE FREQUENCY CLOSE. SOME SLIGHT INTERACTION BETWEEN RESONANCE AND MATCH IS NORMAL. THESE ADJUSTMENTS CAN BE DONE AT GROUND LEVEL ON A SIMILAR DIAMETER TUBE TO YOUR MAST DIAMETER. SURROUNDING OBJECTS WILL HAVE A SMALL EFFECT ON BOTH RESONANCE AND MATCH. M2 ALWAYS SUGGESTS YOU SET THE RESONANCE SLIGHTLY HIGH TO OFFSET MOISTURE EFFECTS.

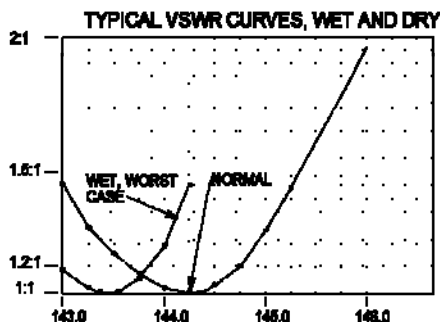
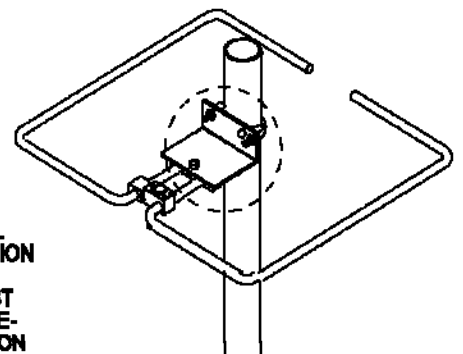

222 HO LOOP STACK KIT

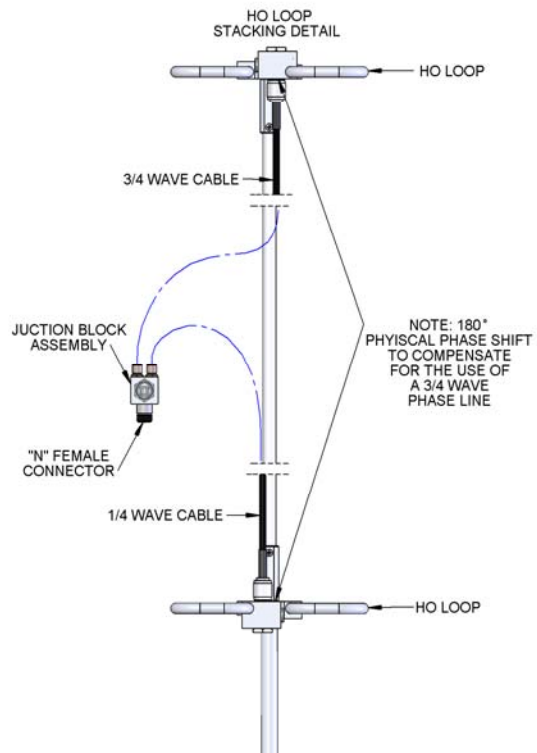

Mount both antennas with no phasing cables installed. Make sure the feed connectors are facing each other and the larger feed blocks are on the opposite side on each antenna. (2M and 222 only). Creating a 180° phase shift.

Connect your feedline to the top antenna and tune to resonance (see tuning instructions).

Connect your feedline to the bottom antenna and tune to resonance at the same frequency as the top antenna.

Connect the phasing lines and adjust both antennas in equal dimensions to resonate the system (as needed).

Route your main feedline as shown, seal and water proof your system appropriately.

It is much easier to tune HO loops using an antenna analyzer, since your initial tuning may be beyond the transmit range of your radio. HO loops are sensitive to their surroundings, so it is best to tune the antenna(s) in their final position, whenever possible.

MOUNTING & OPTIONAL KITS

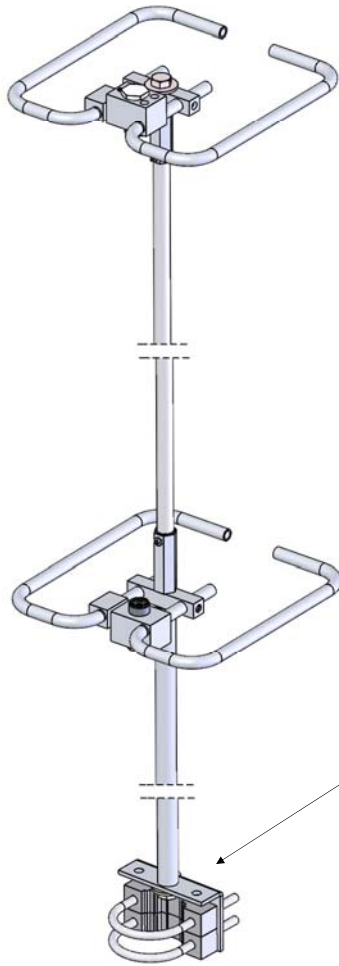

UNIVERSAL MAST
BRACKET KIT
(PT# FGMASTBRKTKIT)

SIDE MOUNT
OR
TOP MOUNT

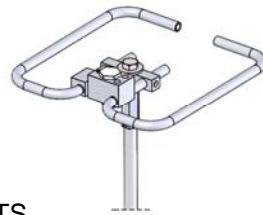
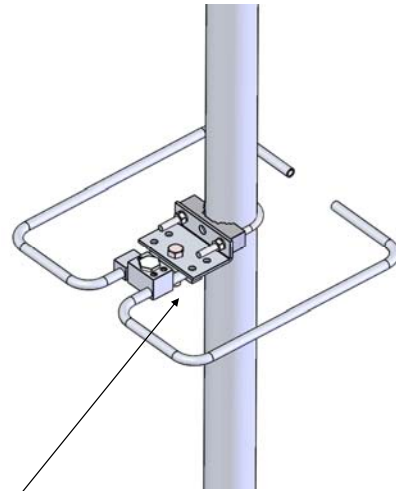

STACKING KITS
FOR
6M, 2M, 222, 432

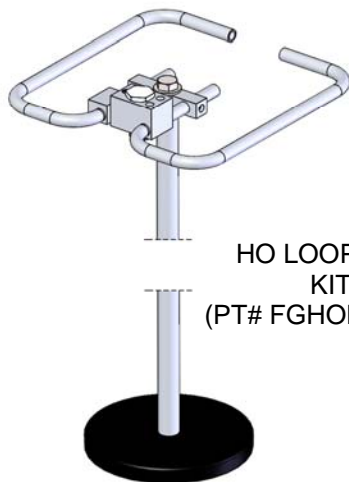

HO LOOP MAG
KIT
(PT# FGHOMAGKIT)

BIG FOOT MAG
MOUNT
(PT# FGBIGFOOT)

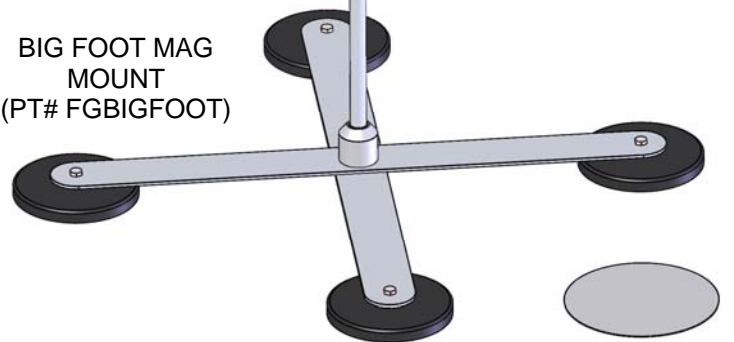

222 HO LOOP PARTS & HARDWARE

HO LOOP, STANDARD PARTS LIST

<u>DESCRIPTION</u>	<u>QTY</u>
H.O. LOOP HALF	2
H.O. FEED ASSEMBLY WITH SO-239 CONN	1
H.O. SHORTING BAR	1
SET SCREW, 1/4-20 X 1/4 S.S.	6
ALLEN WRENCH, 1/8	1
BOLT, 3/8-24 X 1" SS	1
FLAT WASHER, 3/8 SS	1
ASSEMBLY MANUAL	1

OPTIONAL HO LOOP-STACK KIT (# FGSTACKKIT220)

<u>DESCRIPTION</u>	<u>QTY</u>
COAXIAL CABLE RG-59 X 33" @ 3/4 W/L	1
COAXIAL CABLE RG-59 X 11" @ 1/4 W/L	1
LOOP MAST, 5/8 X 18"	1
LOOP MAST 1/2 X 32"	1
ASSEMBLY MANUAL	1
HARDWARE BAG	
JUNCTION BLOCK	1
STUD, 3/8 X 24 X 1-1/2"	1
3/8 FLAT WASHER	4
NUT SEAL	2
CABLE TIES	2

OPTIONAL MAG-MOUNT KIT (# FGHOMAGKIT)

<u>DESCRIPTION</u>	<u>QTY</u>
5" MAGNET	1
MYLAR COVER	1
MAST, 5/8 X 18"	1
BOLT, 3/8-24 X 1/2 S.S.	1
FLAT WASHER, 3/8 S.S.	2
CABLE TIES	2

OPTIONAL MAST BRACKET KIT (# FGMASBRKTKIT)

<u>DESCRIPTION</u>	<u>QTY</u>
HO LOOP MAST BRACKET (M2APT0064)	1
UNI-CRADLE(M2AMC0076)	2
U-BOLT, 2" SS	2
BOLT, 3/8-24 X 1.5 SS	1
LOCKNUT, 3/8-24 SS	1
LOCKWASHER, 1/4 SS	4
NUT, 1/4-20 SS	4