

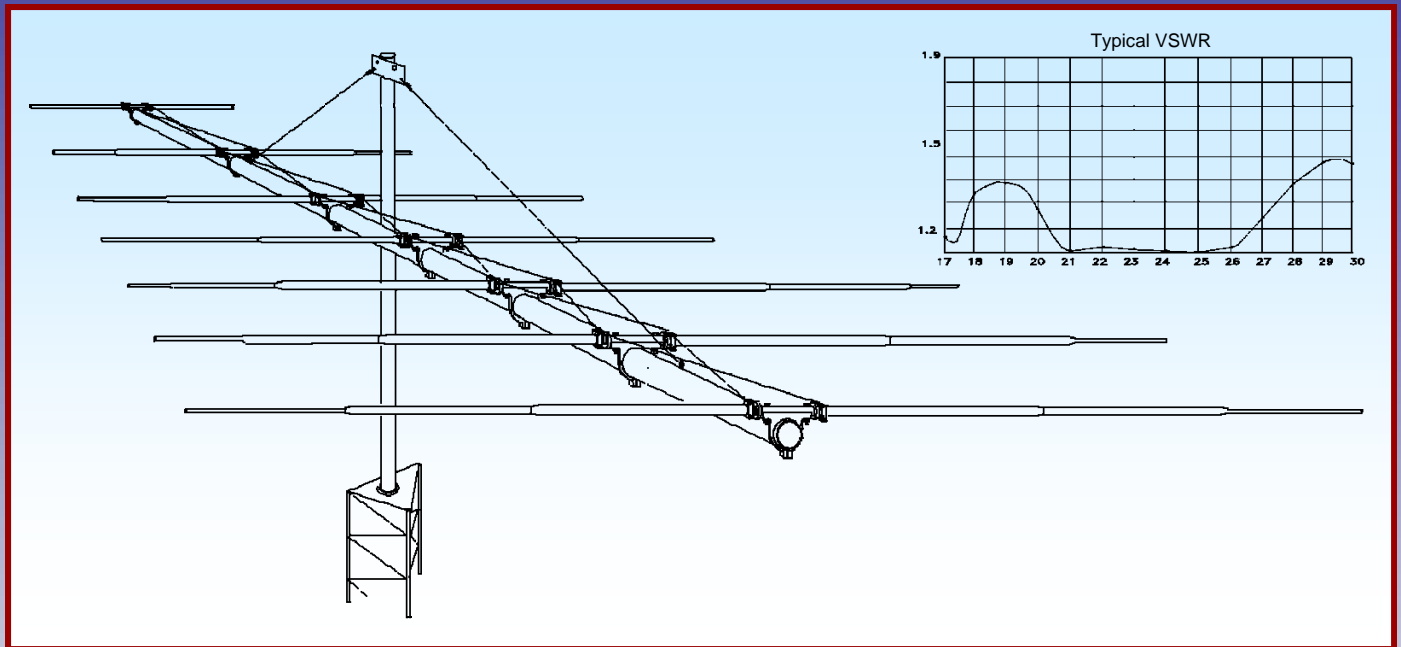

# M2 Antenna Systems, Inc.

## Model No: 17-30LP7-125



### SPECIFICATIONS:

Model .....	17-30LP7-125	Power Handling .....	3 Kw, Higher avl.
Frequency Range .....	17-30 MHz Continuous	Boom Length / Dia .....	23' 8" / 2.0 x .125 Wall
Gain .....	6.6 dBi	Maximum Element Length ....	29 Ft.
Front to back .....	20 dB	Turning Radius:.....	19 Ft.
Beamwidth .....	E=65°	Mast Size .....	2" to 3" Nom.
Feed Impedance.....	50 Ohms Unbalanced	Wind area / Survival .....	6.5 Sq. Ft. / 125 MPH
Maximum VSWR .....	1.5:1	Weight / Ship Wt. ....	65 Lbs. / 73 Lbs.
Input Connector .....	SO-239, Other avl.		

**\*Subtract 2.14 from dBi for dBd**

### FEATURES:

The 17-30LP7-125 Log Periodic is a RUGGEDIZED, yet low wind load antenna designed for the amateur who wants coverage of the 17, 15, 12, and 10 meter bands and still have enough mast capacity for an HF mono-bander or two. Machined aluminum element-to-boom clamps, solid fiberglass rod center-insulators and stainless steel hardware ensure the performance and longevity of this unique antenna. The 17-30LP7-125 is a single feed line system that matches up well with today's solid-state equipment and keeps you competitive at every frequency on every band instantaneously. It's solid electrical and structural design will maintain communications when other antennas have faded into the noise.

**M2 Antenna Systems, Inc. 4402 N. Selland Ave. Fresno, CA 93722**  
**Tel: (559) 432-8873 Fax: (559) 432-3059 Web: www.m2inc.com**

©2015 M2 Antenna Systems Incorporated

05/26/15  
Rev.02

# 17-30LP7-125 ASSEMBLY MANUAL

Toos required: 1/2 and 7/16 end wrench and sockets, 11/32 wrench or socket (spin-tight) phillips ans flatblade screwdriver and tape measure.

## **USE THE ZINCE PASTE PROVIDED OR EQUIVALENT ON ALL JOINTS.**

1. Identify the 2" O.D. and 2.5" O.D. BOOM SECTIONS and lay out by position. Note the REAR section has an 11/16" hole 48" from the butt end. The middle section is 2.5 O.D. x 47.5 SBE ( Swage Both Ends). The front boom section has an 11/32" hole 50" from the end.

2. The 2" I.D. RING CLAMPS for boom to element assembly can be roughly pre-positioned on their appropriate boom sections BEFORE ASSEMBLING BOOM. Use a flat-bladed screwdriver to spread each Ring Clamp slightly to ease installation: Install a 1/4-20 x 1" bolt and locknut into all ring clamps and finger tighten.

3. Assemble boom sections using the 1/4-20 x 3.0" bolts and locknuts. Install 5/16" EYEBOLTS into boom - 1 at 48" from rear and 1 at 50" from front.

Before assembling element hardware to Ring Clamps it is helpful to have the boom supported at a comfortable working height with sawbucks or workstands.

4. Locate the 7/8" O.D. FIBERGLASS RODS and slide a pair of polyethylene DISC INSULATORS onto each rod. Position discs just outside of the two innermost hole in each rod (see the Dimension Sheet Drawing). Now assemble the rods to the Ring Clamps using 1/4-20 x 1-3/4" bolts and locknuts.

5. Assemble the small grooved Phasing Line CLAMP BLOCKS to the ELEMENT CLAMPS using the 1/4-20 x 1" Flathead Screws and locknuts. Then add the 8-32 x 1-3/4" screws and locknuts to the clamp fingers. Just fingertighten nuts. Place one of these Element Clamp assemblies onto the butt end of each 1" O.D. ELEMENT SECTION. Position the Element Clamp 3/8" in from end, with Clamp Block flush with butt end. Then adjust assembly on element so Phasing line clamp is on top and the 9/32" mounting holes in tubing are vertical.

6. See the element layout drawing and assemble according to description of each element. Install the large phasing line clamp blocks on each element butt. Then assemble each half element on to the fiberglass rod center insulators using 1/4-20 x 1-1/2" bolts and locknuts. Place the completed elements on the ring clamps, add two, 1/4-20 x 1-3/4" and locknuts and tighten securely.

7. Now orient boom so 5/16" Eyebolts are straight up and down. Sight down boom from rear and align element #1 square (at right angles) to the Eyebolts and 1/2" from end of boom. Then tighten the 1/4-20 x 1" Ring Clamp bolt and locknut. Align the remaining elements to element #1 and ADJUST FOR CORRECT CENTER -TO-CENTER SPACING OF RING CLAMPS. SEE THE DIMENSION SHEET. Tighten ALL Ring Clamp Bolts.

# 17-30LP7-125 ASSEMBLY MANUAL

8. The 3/16" aluminum rod PHASING LINES are precut to correct size. Pair up equal lengths. Select the shortest pair and apply a little zinc paste to one end of each. Insert these ends into the lower set of grooves in the clamp blocks of the Front Element (#7). Do not tighten yet.

**Line ends typically are installed flush with edge of clamp but may extend slightly. Lines can be hand bent to improve support and/or clear nearby components.** At the other end of the lines slide on the black Delrin 3/4" X 2-1/4" SPACER. One phasing line passes through each of the adjacent large holes. Orient the smaller hole down, towards the boom. Position the Spacer in the middle of the central crossover section and secure to boom with a large black nylon Tie through the small hole and around boom.

**SEE DIMENSION SHEET FOR ARRANGEMENT OF PHASING LINES.**

9. Apply zinc paste to the free ends of the first phasing line set and place in the lower grooves of the clamp blocks of element #6. When fit and layout are satisfactory, return to the front element and TEMPORARILY tighten the clamp screws ( the balun will be attached here later). **Remember, the Element Clamp is still loose, so slide it out the element a little so you can get a screwdriver into the flathead screw. The clamp will be repositioned later.**

10. Select the next shortest pair of phasing lines. Apply zinc paste and install in upper grooves of element #6 clamps. Then add delrin Spacer, the zinc paste to the free ends, and install to lower grooves in element #5 clamps. When fit and layout are satisfactory , tighten 1/4-20 clamp screws on element #6 . **Then reposition Element/Phasing Line Clamps back to 3/8" from butt end of tubing and tighten the 8-32 clamp screws.**

11. Continue with longer pairs of Phasing Lines until finished. Lines for Element #1 are installed in lower clamp grooves. **REMEMBER TO USE THE ZINC PASTE AND TO REPOSITION AND TIGHTEN THE ELEMENT CLAMPS FOR EACH COMPLETED ELEMENT!**

12. Attach the Balun to the 3" x 4" Mounting Plate with a 2-1/2" U-bolt. Tighten only enough to secure Balun-DO NOT OVERTIGHTEN. Position to allow access to other U-bolt holes in Plate (see Dimension Sheet). Install Balun/Plate to boom with 2" U-bolt. Orient Balun with connector pointing to FRONT and leads easily reaching Phasing Line Clamp Screws. Remove clamp nuts. Apply zinc paste to lead lugs and place over screws. Replace locknuts and tighten. **REMEMBER TO REPOSITION THE ELEMENT CLAMP AND TIGHTEN THE 8-32 SCREW AND LOCKNUT!**

13. Attach the BOOM-TO-MAST PLATE to the boom with two 2.5" U-bolts, centering it at 148" (12'4") from rear of boom. Some hand forming of Phasing Lines may be necessary to assure no contact can occur with the mast. Attach a section of feedline to Balun, looping up and over front of boom, and route back underneath boom to the Mast Plate. Three nylon Ties are provided for support.

# 17-30LP7-125 ASSEMBLY MANUAL

## OVERHEAD BOOM SUPPORT SYSTEM

14. Attach one end of the 5/16" Dacron Rope to each of the 5/16" Eyebolts in the boom. Make 2 turns around the eye and secure a series of three half hitches or equivalent.

Seal cord ends with heat or flame and tape ends to main line. Pull lines HARD to set knots.

15. Temporarily install a 2" U-bolt through the Turnbuckle Plate. Thread on nuts until about 1/2" of threads are showing. Insert these threads through the top set of 2" U-bolt holes in the Boom-to-Mast Plate and add two more nuts. Adjust the turnbuckle eyes until threads are flush with inside of turnbuckle body. Hook the turnbuckles into the turnbuckle Plate. Equalize the Dacron cord to the plate and cut it. Make two turns through the turnbuckle eyes, pull rope as tight as possible, and make knots as in step 13. Cut off excess cord over 12", seal ends with heat or flame, and tape to main lines. Now remove the U-bolt from the Turnbuckle Plate and Boom-to-Mast Plate. The Boom Support is now centered and ready for adjustment during antenna installation.

16. The Turnbuckle Plate is secured to the mast with a 2" U-bolt and then pushed up the mast until the boom is straight. Then the U-bolt is tightened. If possible, let the support system take a "set" overnight. The Dacron cord will not stretch, but system components will take a "set" and the boom may droop just a bit. Make final adjustments with the turnbuckles. Note: if your boom continues to sag after the first adjustment, it may mean your knots are slipping.

17. When mounting the 17-30LP7 125 on a tower or mast with other antennas, there may be interaction if they are resonant in the 17-30 MHz band. In general, VHF/UHF antennas with HORIZONTAL POLARITY should be mounted at least 40" above or below the Log.

The VERSATILE 17-30LP7 125 covers 4 amateur bands and everything in-between. ENJOY!

Carefully designed and manufactured in the U.S.A. by:

### **M<sup>2</sup> ANTENNA SYSTEMS, INC.**

4402 N. SELLAND AVE.

FRESNO, CA 93722

(559) 432-8873 FAX: 432-3059

www.m2inc.com Email: sales@m2inc.com

# 17-30LP7-125 DIMENSION SHEET

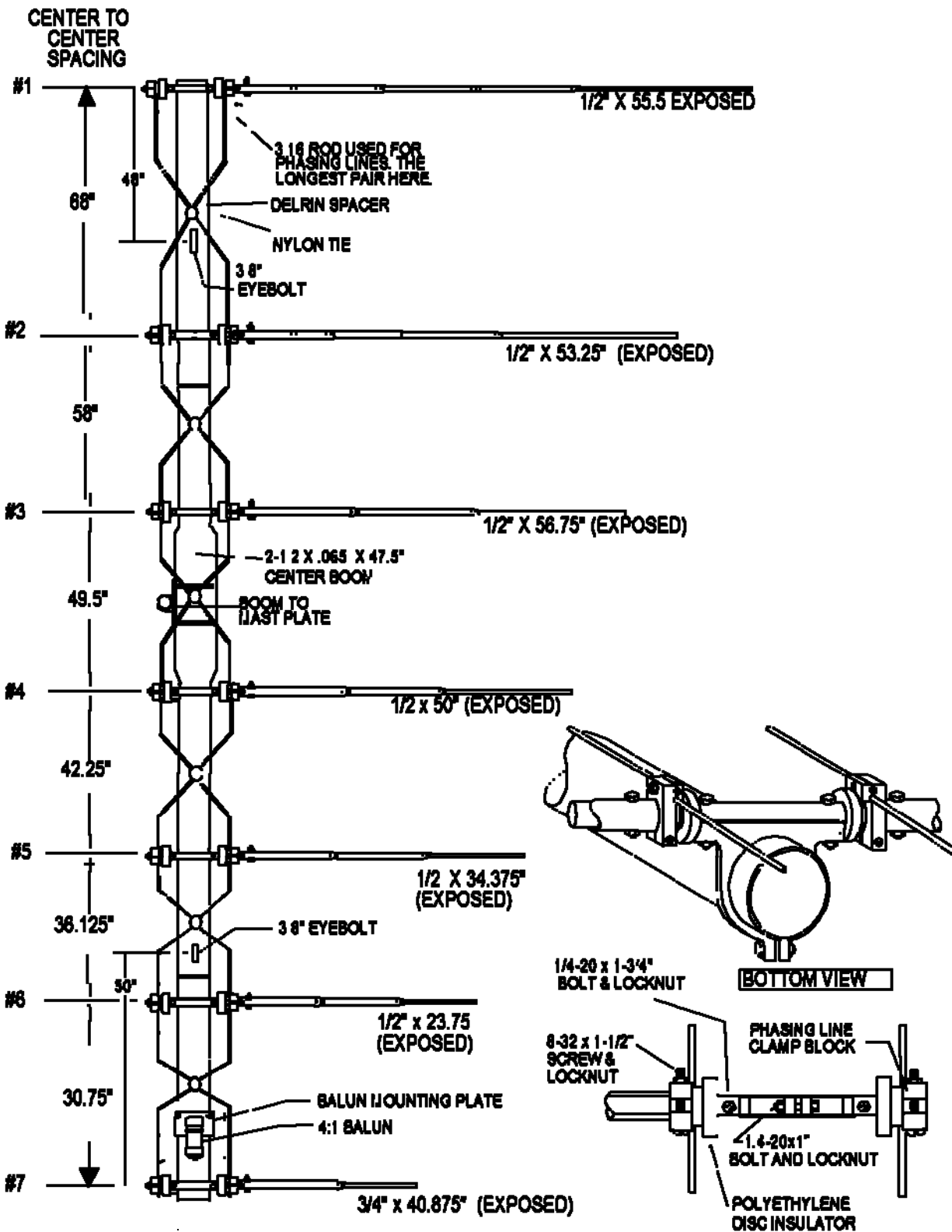

# 17-30LP7-125 ELEMENT LAYOUT

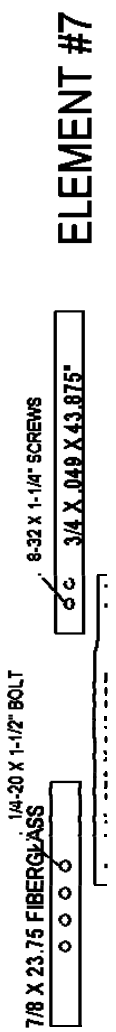
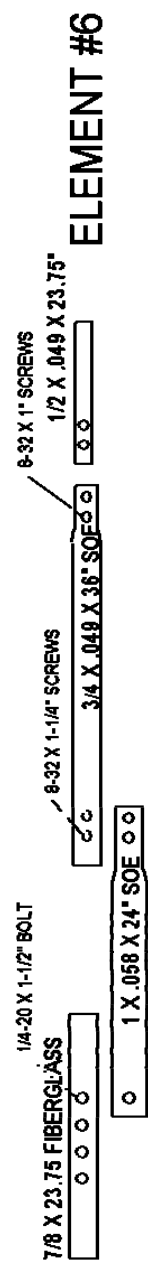
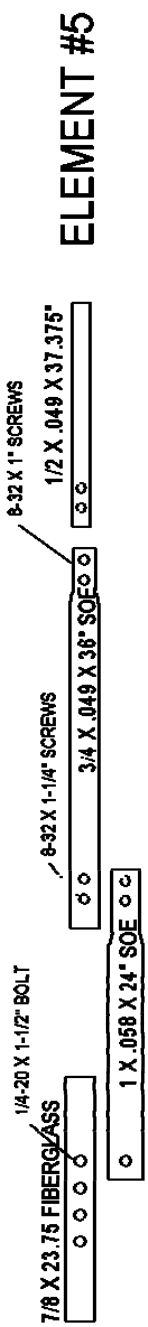
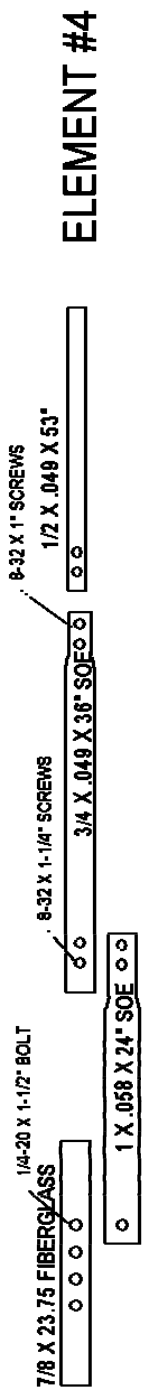
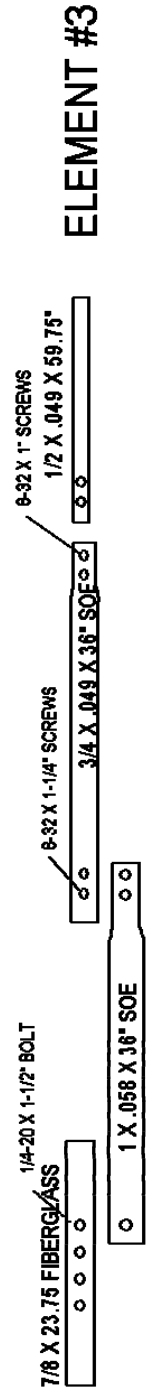
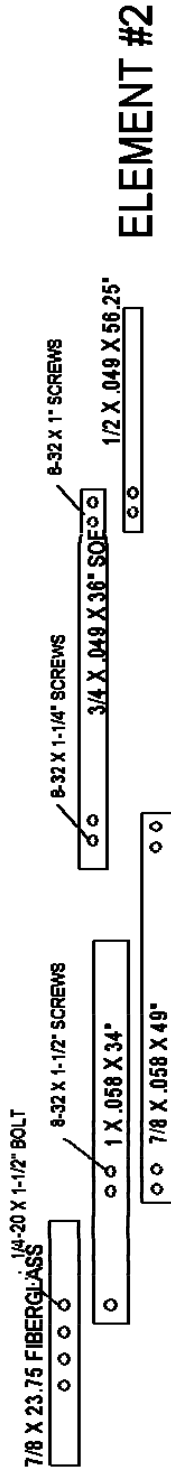
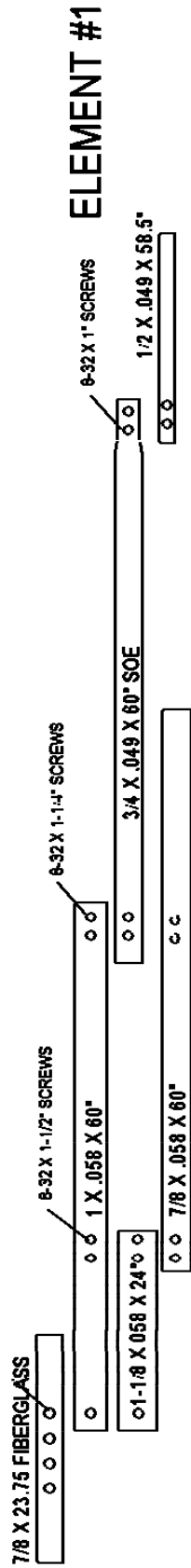

# 17-30LP7-125 PARTS & HARDWARE

<b>DESCRIPTION</b>	<b>QTY</b>
Boom section 2" x .125 x 115.5	1
Boom section 2" x .125 x 132	1
Boom section 2.5 x .125 x 47.5 SBE	1
Element section 1.125 x .058 x 23.5	2
Element section 1 x .058 x 60"	2
Element section 1 x .058 x 34.0	2
Element section 1 x .058 x 36.0 SOE	2
Element section 1 x .058 x 24.0 SOE	8
Element section 7/8 x .058 x 60	2
Element section 7/8 x .058 49.0	2
Element section 3/4 x .049 x 60" SOE	2
Element section 3/4 x .049 x 36.0 SOE	10
Element section 3/4 x .049 x 43.875	2
Element tip, 1/2 x .049 x see DIM. sheet	12
Rod insulator, 7/8" x 29.75" fiberglass (M2AFG0041)	7
Rod, phasing, 3/16 x 71" aluminum	2
Rod, phasing, 3/16 x 61" aluminum	2
Rod, phasing, 3/16 x 52.5" aluminum	2
Rod, phasing, 3/16 x 45.25" aluminum	2
Rod, phasing, 3/16 x 39" aluminum	2
Rod, phasing, 3/16 x 34" aluminum	2
Boom to mast plate, 6 x 8 x 1/4" (2.5 x 2.0) (M2APT0084)	1
Balun, 4:1 ferrite 3 Kw, standard	1
Assembly Manual	1
<b>MAIN HARDWARE BAGS:</b>	
Ring clamp, 2" machined (M2AEC0200)	7
Phase Line Clamp, 3/8" x 1-1/4" x 2-3/16" (M2APL0033)	14
Rod clamp block 1/4 x 3/4 x 1-1/4" (M2APL0067)	14
Disc insulator, 3/8" x 2" poly with 7/8" hole (M2ADI0040)	14
Phase line standoff, 3/4 x 2-1/4" Delrin (M2ASO0060)	6
Turnbuckle plate, 2 x 5 x 1/4" (M2APT0110)	1
Eyebolts, 5/16" X 4", zinc	2
Turnbuckle, 5/16" hook and eye	2
Balun mounting plate, 2" x 4-1/4" x 1/8" (M2APT0014)	1
Support line, 5/16" dacron, 16 foot	1
U-bolt, 2" with cradle	6

# 17-30LP7-125 PARTS & HARDWARE

U-bolt, 2-1/2" with cradle	3
Nylon ties, large, 14.5" black	9
Lockwasher, 5/16" split ring stainless	16
Bolt, 1/4-20 x 3.0 stainless	4
Bolt, 1/4-20 x 1-3/4" stainless	14
Bolt, 1/4-20 x 1-1/2" stainless	14
Bolt, 1/4-20 x 1" stainless	7
Screw, 1/4-20 x 1" stainless, countersunk flathead	14
Nut, 1/4-20 locking, stainless	53
Screw, 8-32 x 1-1/2	26
Screw, 8-32 x 1-1/4	24
Screw, 8-32 x 1"	12
Nut, 8-32 locking, stainless	62
Zinc paste (Penetrox, Noalox or equivalent) 1 ounce	1
Nut, 5/16-18 stainless	16

**M<sup>2</sup> ANTENNA SYSTEMS, INC.**  
4402 N. SELLAND AVE.  
FRESNO, CA 93722  
(559) 432-8873 FAX: 432-3059  
[www.m2inc.com](http://www.m2inc.com) Email: [sales@m2inc.com](mailto:sales@m2inc.com)