

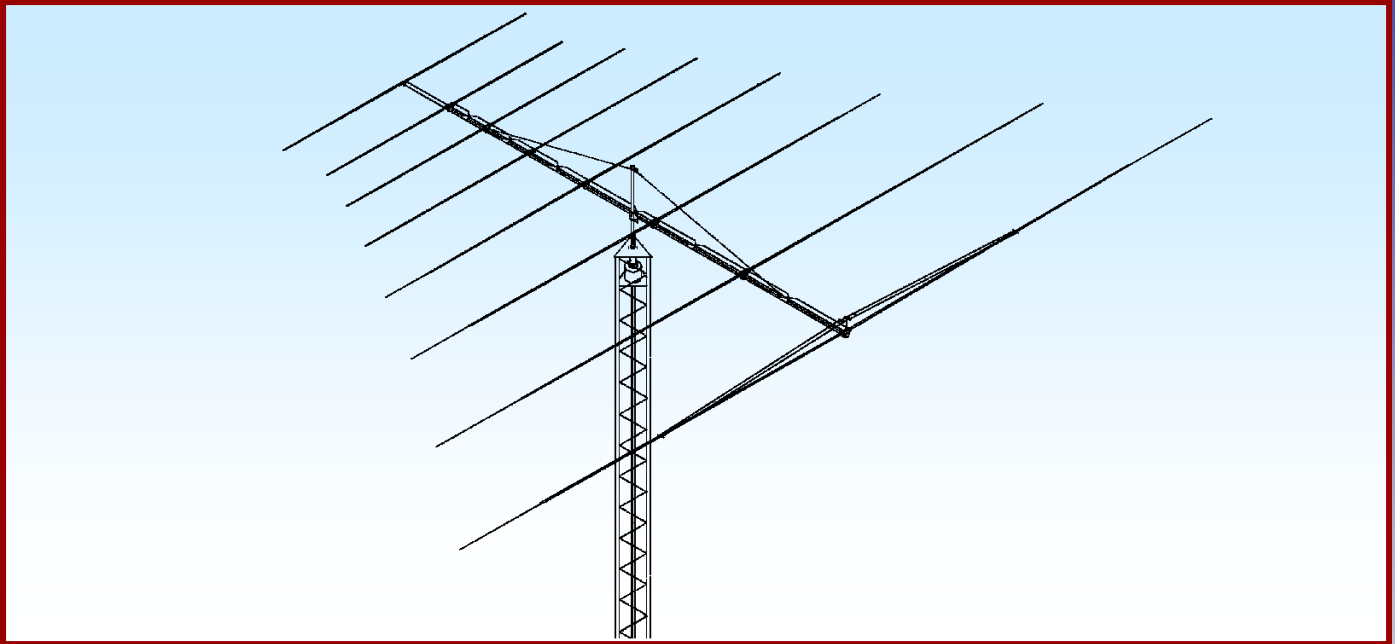

# M2 Antenna Systems, Inc. Model No: 8-30LP9



## SPECIFICATIONS:

Model .....	8-30LP9	Power Handling .....	3 Kw, Higher avl.
Frequency Range.....	8 To 30 MHz	Boom Length / Dia.....	48' X 4&3" X 0.125 wall
*Gain .....	9.5 dBi @ 70' OG	Maximum Element Length.....	50'
Front to back .....	12 dB	Turning Radius: .....	36'
Feed Impedance. ....	50 Ohms Unbalanced	Wind area / Survival .....	18 Sq. Ft. / 100 MPH
Maximum VSWR.....	1.9:1	Weight / Ship Wt.....	170 lbs. / 190 lbs.
Input Connector.....	SO-239, "N" Female avl.		

**\*Subtract 2.14 from dBi for dBd\* (OG = Over Ground)**

## FEATURES:

This special hybrid log periodic is a rugged versatile performer designed for years of trouble free service. Machined aluminum element to boom clamps and solid fiberglass rod center insulators are just a few of the unique structural features in this remarkable antenna. The 8-30LP9 is a single antenna system that matches up with today's modern solid state equipment.

Maritime, Government, Commercial, MARS and Scientific users will find that the 8-30LP9 reliably fills a variety of communication requirements. When properly installed at 65 feet or higher this nine element antenna is a world wide, world-class performer. Solid electrical and structural design will maintain communications when other antennas have long since faded into the noise.

# 8-30LP9 ASSEMBLY MANUAL

**BEFORE YOU BEGIN:** Look over the **DETAIL DRAWINGS, ELEMENT ASSEMBLY AND DIMENSION SHEET**, to get familiar with the various parts of the log periodic. Tools handy for assembly process: Phillips screwdriver, 11/32, 7/16, 1/2, & 9/16" nut drivers, end wrenches and/or sockets, measuring tape.

**Two containers of zinc paste (Penetrox, Noalox, or equiv.) have been provided to enhance and maintain the quality of all electrical junctions on this antenna. Apply a thin coat wherever two pieces of aluminum come in contact or any other electrical connections are made. We also recommend dabbing the end threads the bolts and screws with the zinc paste just before you install them. This adds long term protection to the hardware, reduces friction and lets you get each bolt or screw tighter on the first tightening.**

1. **ASSEMBLING ELEMENT #1, 2 & 3 MOUNTING PLATES.** See the "DETAIL, ELEMENT #1,2 AND #3" drawing. The back three large elements will mount on the four inch boom. This requires 6" x 6" x 1/4" flat plates. 1-1/4" saddles hold the 1-1/4" diameter fiberglass rod center insulators and the plates mount on the boom with 4" saddles. Element #1 and 2 have 3/4" vertical support risers. Element #3 does not. The center insulator is 1-1/4" diameter. Push on two 1-1/4" poly rings and center them at just over 6" apart. Set this assembly on the 1-1/4" aluminum saddles and add the top saddles. Hardware for this whole assembly is shown on the drawing. Continue adding all the parts shown on the drawing except the elements and the phasing line parts  
**The disc insulators are sometimes a very tight fit on the rods. If so, place them in hot water a few moments before installation.**

## DETAILS, ELEMENT #1, 2 AND 3 (NO RISER)

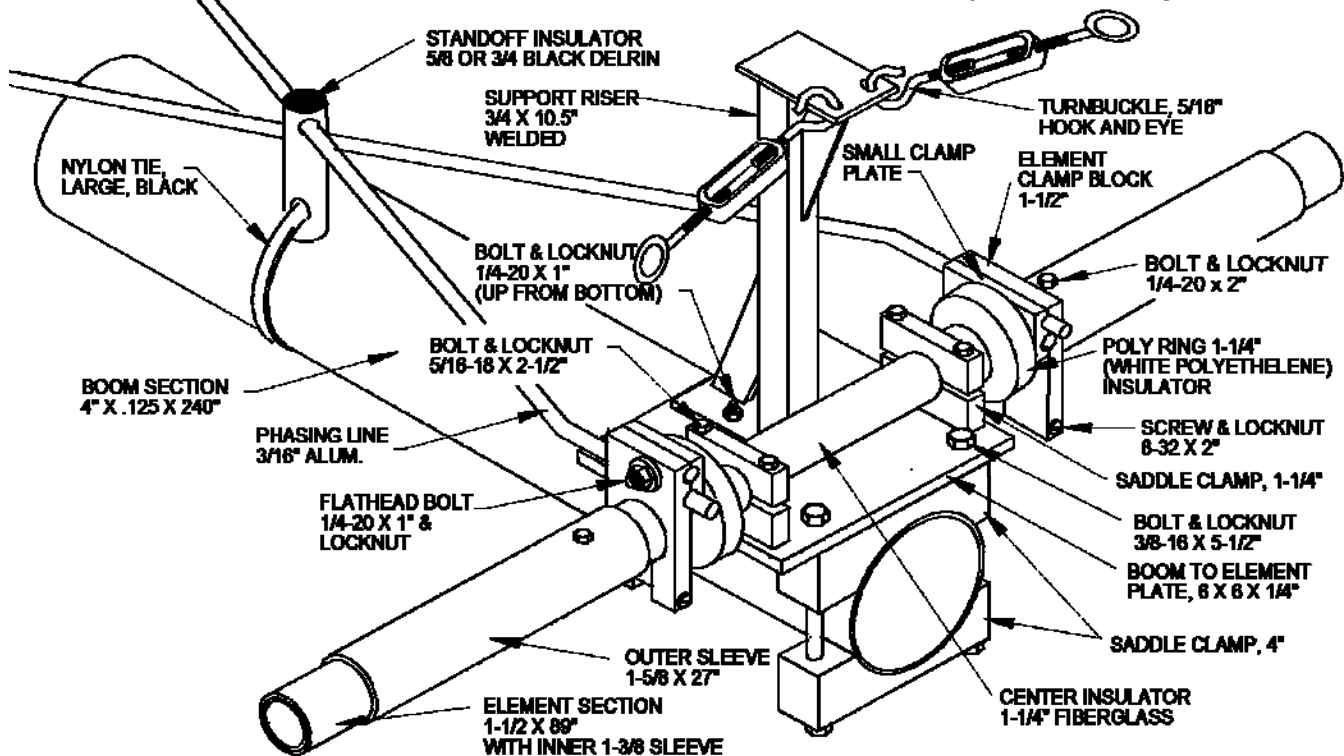

2. **ELEMENT #4 MOUNTING PLATES.** The two 3 x 6 x 1/2" plates milled with a .5" radius channel are for ELEMENT #4. LOCATE THE 1" diameter fiberglass rod and slide on two 1" poly rings and center them just over 6" apart. Clamp this assembly between the two plates. Align the holes in the fiberglass vertical and tighten the hardware. This element attaches to the boom with two 3" saddles. **Center the rod and tighten the hardware EVENLY, so the plates are parallel and the same amount of threads are showing through all the locknuts.**

# 8-30LP9 ASSEMBLY MANUAL

## ELEMENT MOUNTS, #5 THROUGH 8

3. ELEMENT #5 MOUNTING PLATES. Element #5 uses two 2-1/2 x 4" plates and TWO SADDLES to attach it to the boom. A 7/8" diameter fiberglass rod gets two 7/8" I.D. poly rings pushed on and centered just over 4" apart. Align the holes vertical and tighten the hardware.

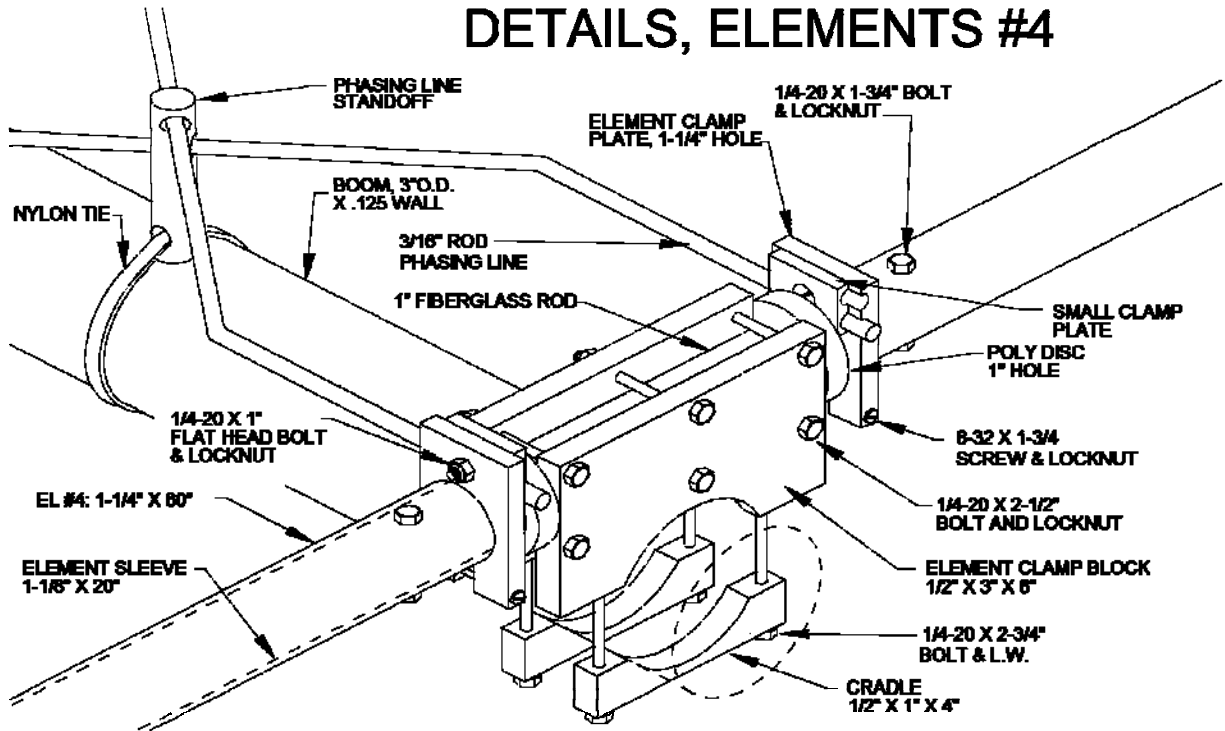

4. Elements #6 through #8 use a single 2-1/2 x 4 x 3/8" plate and a matching rectangular 1-1/2 x 4 x 1/4" clamp plate. The 7/8 x 29-3/4 inch long fiberglass rods each need 7/8" poly rings installed and centered just over 4" apart. Clamp these assemblies between the plates, aligning the holes vertical and tighten the hardware. (Elements #6, 7 and 8 each use a single 3" bottom cradle).

Note: Element #8 is the feed point and a BALUN BRACKET is added to the clamp plate assembly

5. Element #9, the front DIRECTOR element mounts differently, using two 3" machined cradles back to back. It is grounded to the boom. A 7/8" x 30" sleeve couples the two 3/4" element halves together with the same bolts that hold the bottom saddles. Assemble loosely at this time.

## LOG PERIODIC ELEMENT ASSEMBLY

1. REFER TO "ELEMENT ASSEMBLY" SHEET
2. Start with the smallest elements. Elements #8, #7, #6 and #5 are similar. There are two halves to each element. Do the following for both halves. Locate and install a 1" hole, ELEMENT CLAMP BLOCK 1/4" from the butt end of a 1" x 48" section. Use an 8-32 x 1-1/2" screw and locknut. Orient the clamp block so its upper hole is aligned with the hole in the butt of the tube. Locate a small clamp plate and attach it loosely to the inside of the element clamp block using a 1/4-20 x 1" flat head bolt and locknut. Now add the 3/4" section on element #8 and secure using 8-32 hardware shown on the drawing. Finally, slide each element half over the center 7/8" fiberglass rod insulator assembly and secure with 1/4-20 x 1-1/2" bolts and locknuts. When element #8 is complete, set it aside and continue finalizing elements 7, 6, & 5.

# 8-30LP9 ASSEMBLY MANUAL

**NOTE:** THE FOLLOWING ELEMENTS HAVE SLEEVED SECTIONS. MOST ARE IN PLACE FROM THE FACTORY BUT IF NOT, WIPE THE SLEEVE CAREFULLY AND LUBE LIGHTLY WITH OIL OR W4-40 PRIOR TO INSERTION. IF THE SLEEVE STICKS OR BINDS AT ALL, **STOP, STOP STOP**. DO NOT GO FURTHER, REMOVE CAREFULLY AND CLEAN AGAIN. IT MAY ALSO BE NECESSARY TO PUSH A CLEAN CLOTH THROUGH THE ELEMENT BEFORE TRYING THE INSERTION AGAIN. AT THE FACTORY, WE HAVE FOUND THAT WD-40 IS THE BEST AT LOOSENING THE BIND BETWEEN TWO SECTIONS OF ALUMINUM TUBING.

- Element #4 is next. Again place an element clamp block with a 1-1/4" hole at 1/4" from the butt of the element. Align with element hole as before and secure using an 8-32 x 1-3/4 screw and

## DETAILS, ELEMENT #5, 6, 7 AND 8

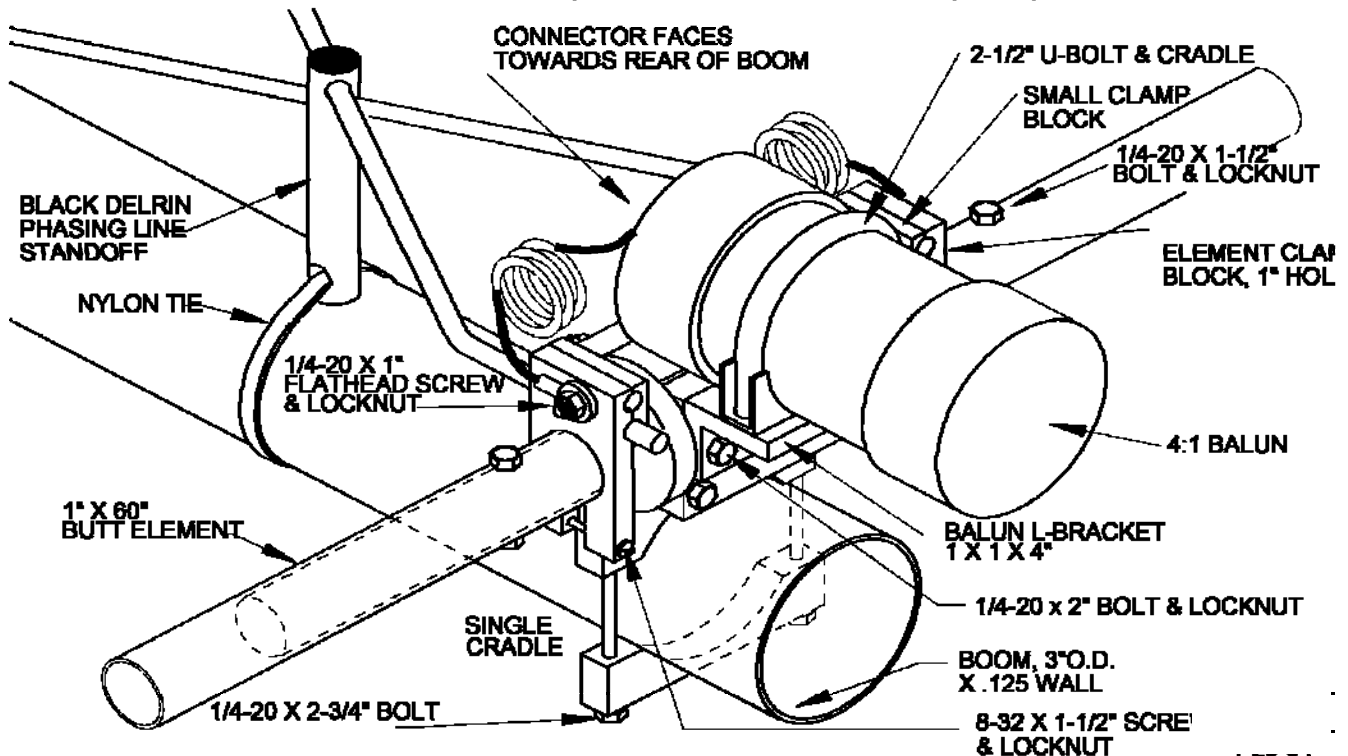

locknut. Add the small clamp block and 1/4-20 x 1" flat head bolt and locknut loosely. If it is not already there, insert a 1-1/8 x 20" sleeve in the butt of the element and hold in place temporarily with a 1/4-20 x 1-3/4" bolt and locknut but don't tighten yet. Continue adding the 1", 3/4 and 1/2" sections securing with the 8-32 hardware listed on the drawing. Tighten each joint securely so no wiggle is felt when moving the element. Finally, remove the 1/4-20 x 1-3/4 bolts and slide each element half on the dual saddle center insulator assembly. Re-install the bolts and tighten.

## DIRECTOR ELEMENT ASSEMBLY

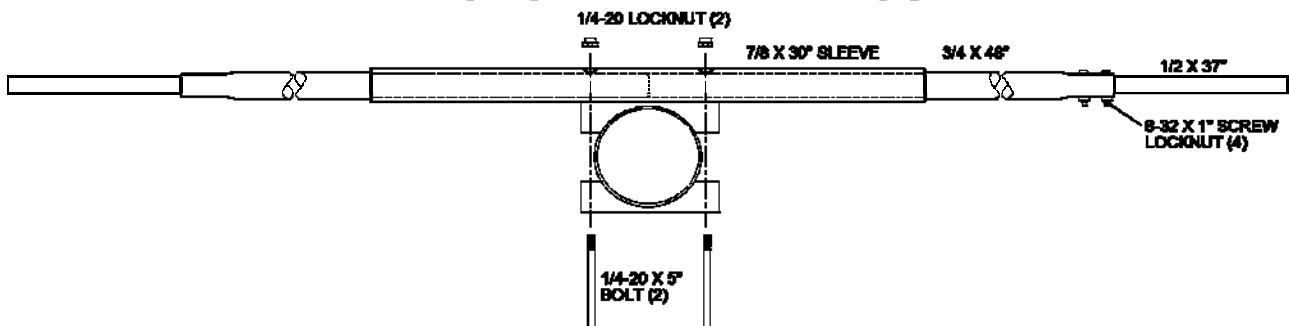

# 8-30LP9 DIMENSION SHEET

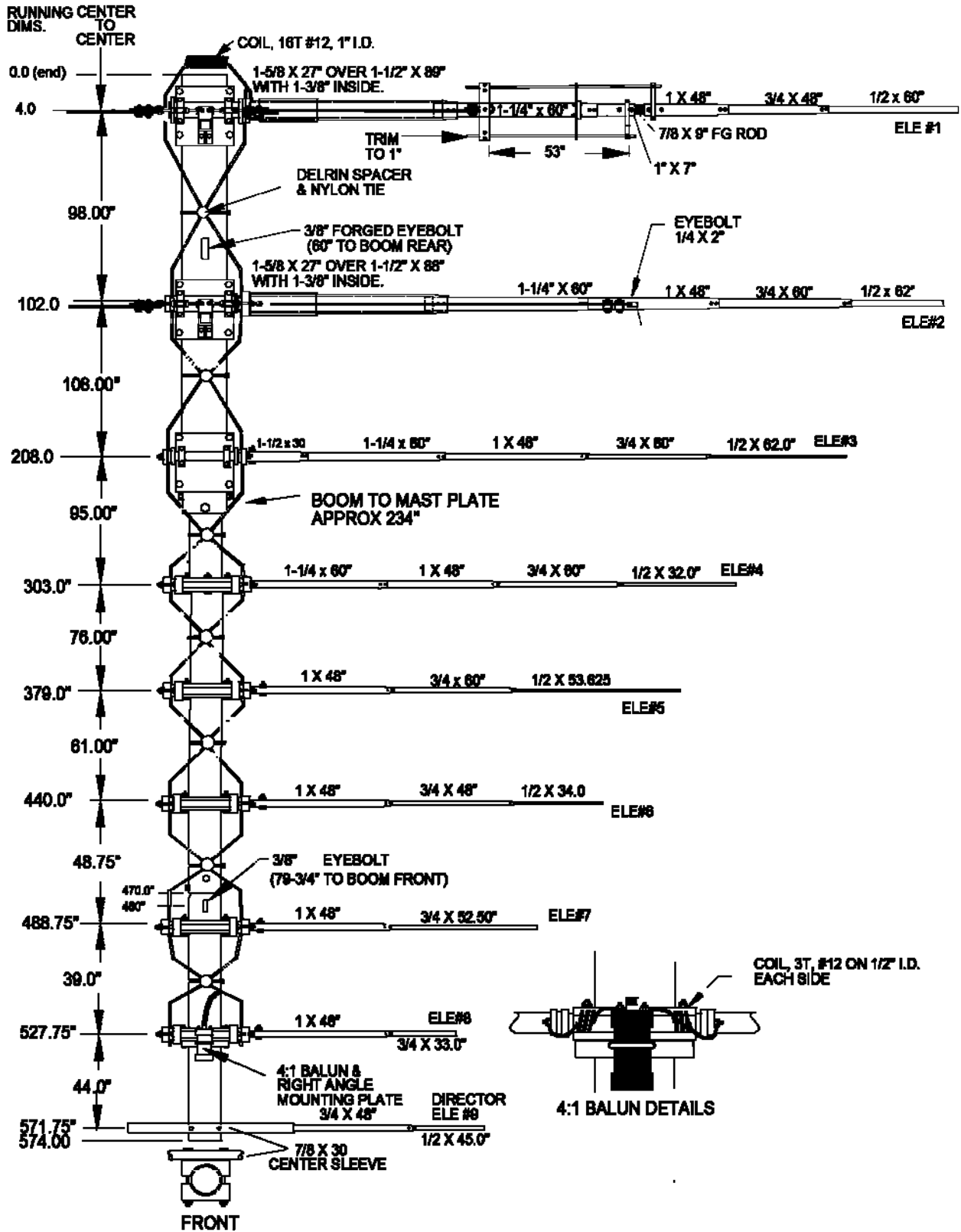

# 8-30LP9 ELEMENT ASSEMBLY

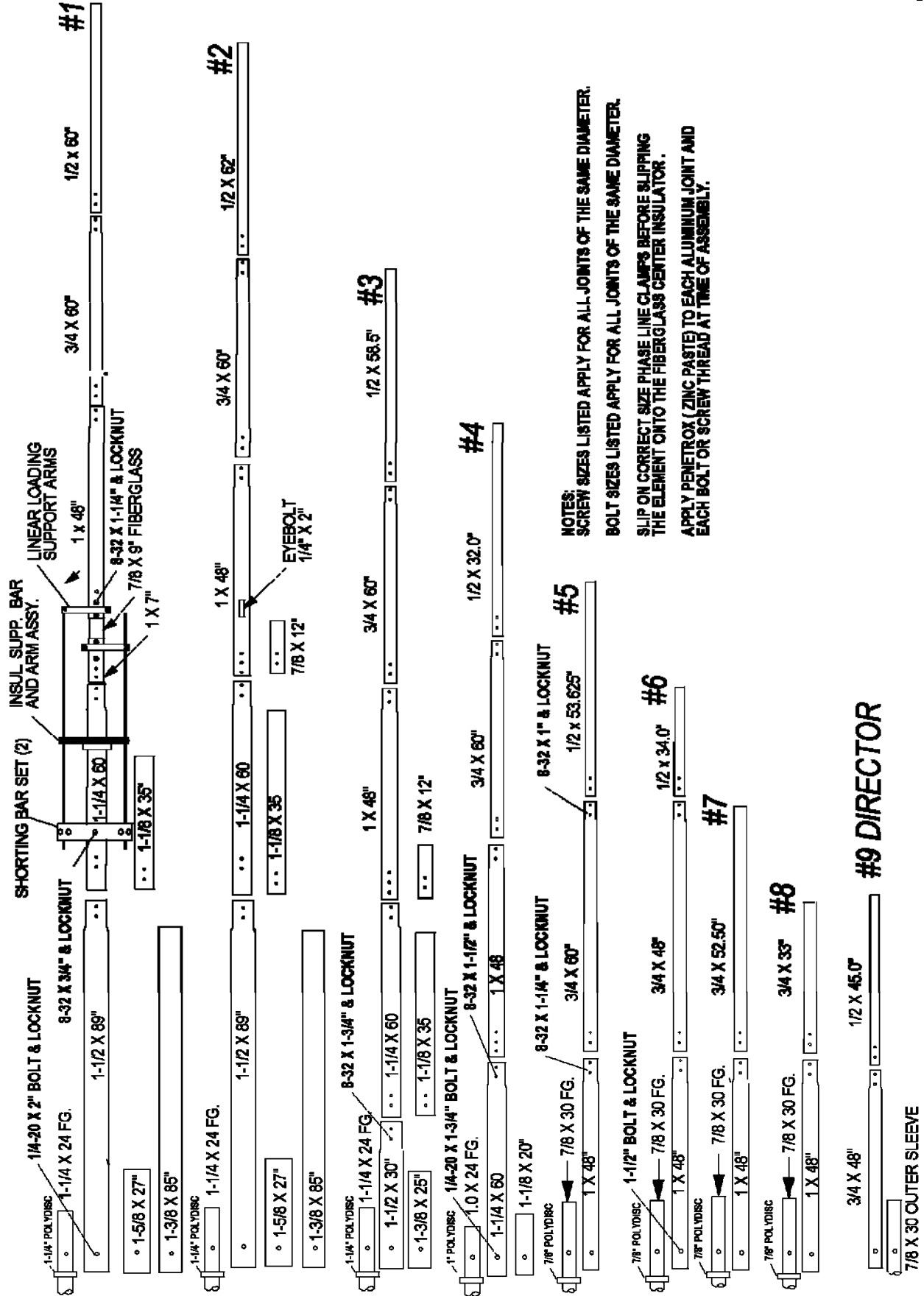

# 8-30LP9 ASSEMBLY MANUAL

4. Element #3 is has 3 internal sleeves as noted on the ELEMENT ASSEMBLY drawing. Again start at the butt and insert the 1-3/8 x 25" sleeve and hold in place with a 1/4-20 x 2" bolt and locknut but don't tighten. Next, install an element clamp block 1/4" in from the end. Secure with 8-32 x 2" screw and locknut, align with the element hole and tighten. Add the small clamp block and secure as before. Now insert ( if not already in) the 1-1/8" x 35" inner sleeve into the butt of the 1-1/4" section and attach to the 1-1/2" section. Continue assembling the rest of the element. Tighten all element hardware. Finally remove the 1/4-20 x 2" bolts and install the element halves on the center insulator assembly. Re-install the bolts and tighten.
5. Element #2 has an outer 1-5/8 x 27" sleeve and an inner 1-3/8 x 85" sleeve. The inner sleeve should already be in place from the factory. Slide on the outer sleeve and hold in place using another 1/4-20 x 2" bolt and locknut but don't tighten. Next slip on another ELEMENT CLAMP BLOCK with a 1-1/2" hole. Note that the very end of the element is still 1-1/2" O.D. secure the clamp at 1/4" from the butt end of the element and secure with 8-32 x 2" screw and locknut aligning as before. Add the small clamp block and secure loosely with another 1/20 x 1" flat head bolt and locknut. As you insert the next 1-1/4" section, note that it goes in 5" instead of the normal 3". This is so it can couple with the last inch or so of 1-3/8" sleeve inside the 1-1/2" section. This overlap is extremely important to maintain the overall strength of the element in this joint. Continue assembling the rest of the element. Tighten all element hardware. Finally, remove the bolts and slip each element half on the center insulator assembly. Re-install the bolts and tighten.

Now install the two 1/4" eyebolts. Install a thimble or cable eye in each eyebolt and attach a 166" length of HPTG-1200 and secure with two clips. Repeat for the other element half. Open the 5/16" turnbuckles till just one thread shows inside the body of the turnbuckle. Add a thimble to each turnbuckle eye and secure the cable at each turnbuckle with two clips.

6. Element #1 is last and requires the most attention. SEE LINEAR LOADED ELEMENT ASSEMBLY drawing. This element is almost the same as #2 except for the linear loading. Prepare the element as shown except for the linear loading (3/16" dia. Rods). Now place the element on a level surface with the support post up. FROM THE ELEMENT BUTT SIDE, feed a 3/16" LINEAR LOADING RODS through the flat, support insulator and into the LL ARMS until 1/2" extends beyond each arm. Tighten the 8-32 x 1/4" set screws. Using the 3/8 x 3" "Push tube", Install two SHAFT RETAINERS, one at a time, onto this rod tip and snug up against each linear loading arm.

NOTE: to start the RETAINER, hold the 3/8 x 3" PUSH TUBE in your hand with one end between your thumb and forefinger. Now center retainer on this end, "dish" into tube, and hold in place with the same thumb and forefinger. Grasp the linear loading rod near the end with your other hand and firmly push the retainer onto the rod.

Next, cut two 9 foot (108") lengths of HPTG 1200 Philistran. Note that one of the two center grooves in the pre-assembled LINEAR LOADING CLAMP assemblies is "on center". Slip about 4" of the HPTG 1200 through the center groove and back through the other so about 2" of cable is there for the 1/8" cable clip. Now slide this assembly on the rods to the dimension shown. Tighten the center screw enough to hold the assembly together. Align it so it is parallel with the ground and tighten all screws. Double check you dimension to make sure nothing has slipped. Correct if necessary. Repeat for the other element half.

Now attach the other end of the HPTG 1200 cables to center 5/16" turnbuckles. Open the turnbuckle first and install a cable eye in each turnbuckle. Pull the lines tight and tighten the clips.

Final tensioning of the linear loading rods is done with the turnbuckles. Adjust until each element droops 10 to 16 inches at the tip. NOTE: The element is most stable in wind with a small amount of droop.

# LINEAR LOADED ELEMENT ASSEMBLY

PRE-ASSEMBLE THE LINEAR LOADING CLAMP PLATES AS SHOWN. LEAVE THE HARDWARE LOOSE UNTIL INSTALLED. USE 8-32 X 1" SCREWS AND LOCKNUTS (10).

POSITION THE ARM AGAINST THE INNER TWO SCREWS AS SHOWN. TUNING MAY BE AFFECTED IF THIS IS NOT DONE.

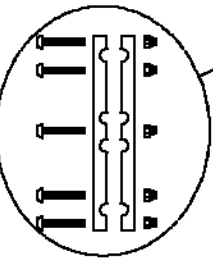
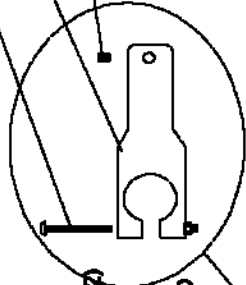
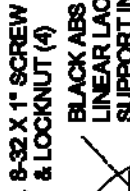
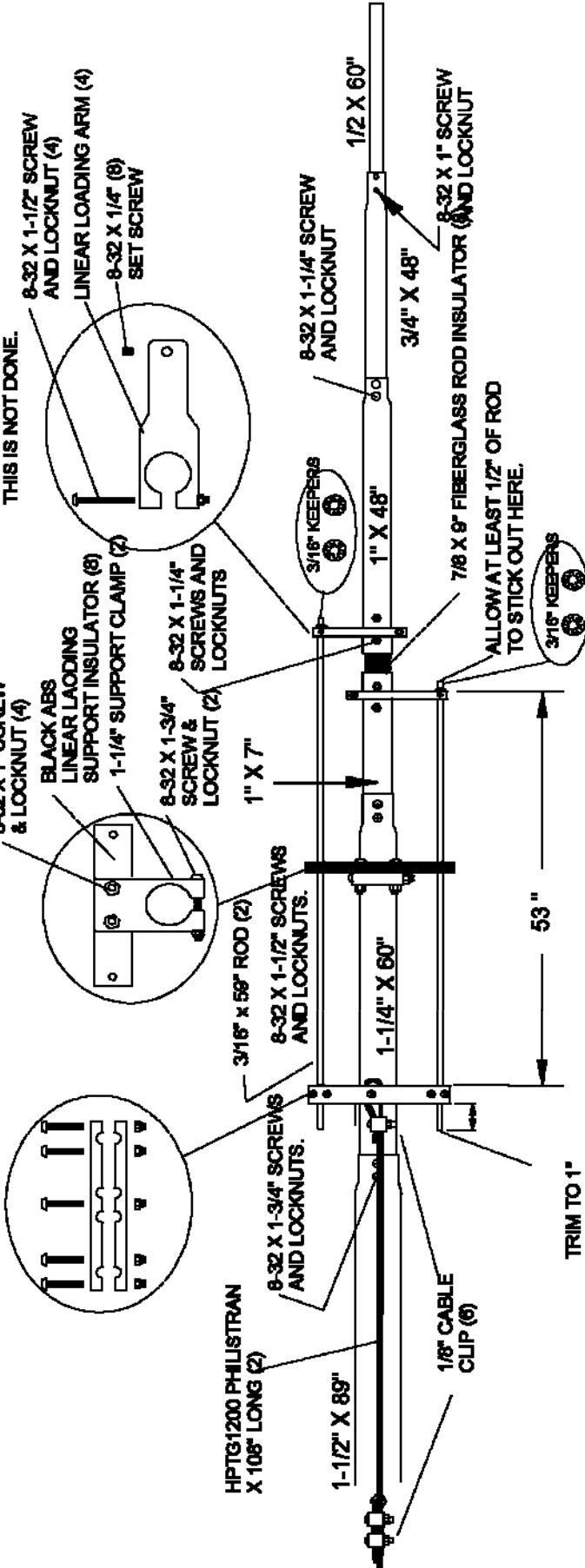



# 8-30LP9 ASSEMBLY MANUAL

## 7. BOOM ASSEMBLY

Wipe off any dirt or grit from the coupling rings on the end of the long 3" section. Also clean the inside of the 4" x 20 foot section. Lubricate the inside of the 4" tube and the coupling rings lightly with oil or zinc paste. Gently insert the 3" section into the 4" boom section. Align the holes, install the 13/8-16 x 4-1/2" bolts and locknuts and tighten. Clean the boom tip section and slip it into the main section. Install the 1/4-20 x 3-1/2" bolts and locknuts.

Install the 3/8 EYEBOLTS to the outer ends of the boom, securing with 3/8-16 nuts and lock washers. Align the eyes parallel with the boom and tighten.

8. Orient the boom with the eyebolts "up". Using a tape measure and a marking pen or masking tape, place a mark 1/2" in from the **rear** of the boom. This will be where you position the back edge of the clamp plate for element #1. Now measure forward 98" from that mark and make another mark for element #2. Continue marking the locations of all the elements using the element spacing figures given on the Dimension Sheet.
9. Attach Element #1, the linear loaded element, to the boom. For ease of element installation, support the boom about 3' above ground, eyebolts "up." Slip Element #1 over the rear of the boom, placing the back edge of the rear plate on your first mark. **ALIGN** the elements horizontal perpendicular to the eyebolts and tighten bolts **EVENLY** and firmly. Use element #1 as the element alignment reference.
10. Mount element #2 and align and tighten as before. Note it is usually easier to begin installing the phasing lines at this time between each new element mounted. Mount the next to the longest pair as shown on the dimension sheet. Hold the spacer in place loosely around the boom with a large nylon tie but don't tighten it yet. Adjust phasing lines so that their bends are even and the lines run parallel to the boom.

**ALSO ATTACH THE 13 TURN COIL ACROSS ELEMENT #1** Tighten only the clamps on Element #1 at this time. After installing element number #3, then install the longest set of phasing lines between #2 and #3 and tighten the clamps at Element #2, and so on. Continue until you get to element #8 where the 4:1 BALUN is attached. Add the two 3 turn COILS to the balun and attach the other end of the coil leads to the bolts that tighten the rod clamps.

11. Now mount the DIRECTOR as shown on the DIMENSION SHEET. Align the completed elements as required with the element #1 at the other end of the boom.

Attach the BOOM TO MAST PLATE using 4 more 4" machined saddles. Mount the plate at the end of the 4" boom section. This should be close to the physical balance point as well. Reshape the phasing lines as needed to clear the plate by at least 1/2".

# 8-30LP9 ASSEMBLY MANUAL

## 12. OVERHEAD BOOM SUPPORT SYSTEM.

Install a temporary mast if possible to get the overhead system just right before installing the antenna.

Attach one end of the HPTG-4000 Philistran cable at the eyebolt at the REAR end of the boom. Install a thimble or cable eye in the eyebolt. Secure the cable using two 1/4" cable clips. Repeat at the other eyebolt. Attach the turnbuckle plate to the mast about 5 feet above the boom to mast plate. Open the 3/8 forged JAW AND EYE turnbuckles till just one thread is showing inside the of the turnbuckle. Attach the JAW end of each turnbuckle at the plate. Insert a thimble or cable eye in each turnbuckle eye and then attach the two HPTG-4000 cable, tensioning the cables and securing with two more clips on each. Do final boom straightening with the turnbuckles now or at the time of installation on the tower.

13. Check ALL hardware for tightness. Check ALL element sections, especially tip sections, for correct placement. Make any final adjustments to linear loading tension.
14. Attach feedline section to balun. Route from element #8, back to boom to mast plate. Secure at regular intervals with tape or nylon ties.
15. When mounting this log periodic on a tower or mast with other antennas there may be interaction with other nearby antennas, particularly if they are resonant in the 8 to 30 MHz band. In general VHF and/or UHF antennas mounted for HORIZONTAL POLARITY should be at least 40 inches above or below the log antenna. Use good quality 50 Ohm feed line to feed the log and be sure your tower and rotator system can handle to wind area and weight of this antenna.

THIS COMPLETES ANTENNA ASSEMBLY

### **M<sup>2</sup> ANTENNA SYSTEMS, INC.**

4402 N. SELLAND AVE.

FRESNO, CA 93722

(559) 432-8873 FAX: 432-3059

[www.m2inc.com](http://www.m2inc.com) Email: [sales@m2inc.com](mailto:sales@m2inc.com)

# 8-30LP9 PARTS & HARDWARE

DESCRIPTION .....	QTY
Boom section, 4" x .125 x 240" .....	1
Boom section, 3 x .125 x 240" straight w/ coupling rings to 3-3/4" ID.....	1
Boom section, 3 x .125 x 108" swaged .....	1
Sleeve, outer, 1-5/8" x .058 x 27 .....	4
Sleeve, 1-3/8 x .058 x 25" .....	2
Sleeve, 1-3/8 x .058 x 85" .....	4
Sleeve, 1-1/8 x .058 x 35" .....	6
Sleeve, 1-1/8 x .058 x 20" .....	2
Sleeve, outer, Director 7/8 x .058 x 30" .....	1
Sleeve, 7/8 x .058 x 12" .....	4
Element butt section, 1-1/2 x .058 x 89" SOE, .....	4
Element butt section, 1-1/2 x .058 x 30" SOE .....	2
Element butt section, 1-1/4 x .058 x 60" SOE 1/4" hole.....	2
Element section, 1-1/4 x .058 x 60" SOE (holes in butt shifted.....	4
Element section, 1-1/4 x .058 x 60" SOE .....	2
Element butt section, 1.0 x .058 x 48 SOE, w/ 1/4" hole.....	8
Element section, 1.0 x .058 x 48" SOE .....	8
Element section, 1.0 x .058 x 7" .....	2
Element section, 3/4 x .049 x 60" SOE .....	10
Element butt section, 3/4 x .049 x 48" SOE 1/4" hole .....	2
Element section, 3/4 x .049 x 48" SOE .....	2
Element tip section, 3/4 x .049 x 52.50" .....	2
Element tip section, 3/4 x .049 x 33.00" .....	2
Element section, 1/2 x .049 x 62.0" .....	2
Element tip section, 1/2 x .049 x 60.0" .....	2
Element tip section, 1/2 x .049 x 58.50 .....	2
Element tip section, 1/2 x .049 x 53.625" .....	2
Element tip section, 1/2 x .049 x 45.0" .....	2
Element tip section 1/2 x .049 x 34.0" .....	2
Element tip section, 1/2 x .049 x 32.0" .....	2
Rod, phasing, 3/16 x 114" .....	2
Rod, phasing, 3/16 x 104.0" .....	2
Rod, phasing, 3/16 x 101.0" .....	2
Rod, phasing, 3/16 x 82.0" .....	2
Rod, phasing, 3/16 x 67.0" .....	2
Rod, phasing, 3/16 x 54.75" .....	2
Rod, phasing, 3/16 x 45.0" .....	2
Linear loading element 3/16 x 108" alum. rod .....	4
Rod insulator, 1-1/4 x 24" fiberglass .....	3
Rod insulator, 1 x 24" fiberglass.....	1
Rod insulator, 7/8 x 29.75" fiberglass.....	4
Rod insulator, 7/8" x 9" fiberglass.....	2
Support post 3/4 sq. x .125 x 10.5" welded alum. tube .....	2
Boom to element plate 6 x 6 x 1/4".....	3
Boom to mast plate, 12 x 12 x 3/8" alum.....	1
Balun, 4:1 ferrite core, 3 kW .....	1
Coil, 16 turn #12 awg on 1" form.....	1
Coil, 3 turns, #13awg on 7/8" form .....	2

# 8-30LP9 PARTS & HARDWARE

## IN HARDWARE BOX

Saddle, 4" machined alum.....	16
Saddle, 1-1/4", machined alum. ....	12
Clamp plate, 1/2 x 3 x 6", .500 radius, alum.....	2
Clamp plate, 3/8 x 2-1/2 x 4" alum. ....	5
Clamp cap plate, 1/4 x 1-1/2 x 4" alum. ....	3
Clamp cradle, 1/2 x 1.0 x 4" alum. ....	9
Element clamp block, 3/8 x 1-3/4 x 2-5/8" with 1-1/2" hole .....	6
Element clamp block, 3/8 x 1-1/2 x 2-7/16" with 1-1/4" hole .....	2
Element clamp block, 3/8 x 1-1/4 x 2-3/16" with 1" hole .....	8
Small phasing line clamp plate, 1/4 x 3/4 x 1-1/4" .....	16
Poly ring insulator, 3/8 x 2" white polyethylene, 1-1/4" hole .....	6
Poly ring insulator, 3/8 x 2" white polyethylene, 1" hole.....	2
Poly ring insulator, 3/8 x 2" white polyethylene, 7/8" hole.....	8
Spacer standoff, 3/4 x 3.0" Delrin, black, .....	7
Linear loading arm, .375 x 1.5 x 4.0" 1" hole.....	4
LL Shorting bar halves, 1/4 x 3/4 x 6~.....	4
Insulator, stabilizer bar, 1/4 x 1 x 6" black ABS bar .....	2
Support arm, for stabilizer bar .375 x 1.50 x 2.875 alum. 1-1/4" hole .....	2
Turnbuckle plate, 2 x 5 x 3/16" .....	1
Balun mounting 'L' bracket, 2 x 4.5 x 1/8 .....	1
Eyebolt, 3/8" x 6" forged .....	2
Eyebolt, 1/4-20 x 2 1/2" zinc.....	2
Turnbuckles, 3/8" eye and jaw, forged .....	2
Turnbuckle, 5/16" hook and eye, stainless.....	4
Support rope, (main boom) 45 ft. HPTG 4000 Philistran, .....	1
Support rope, (element) 46 ft HPTG 1200 Philistran .....	1
Cable eyes, 3/16" .....	6
Cable eyes, 1/4" .....	4
Cable clips, 1/4" .....	8
Cable clips, 3/16" .....	14
U-bolt, 3" (alternate mast clamps).....	3
U-bolt, 2-1/2" .....	1
U-bolt, 2" heavy duty " (mast clamps) .....	4
U-bolt, 2" standard.....	1
Nylon ties, large 14.5" black.....	14
Assembly manual .....	1
Zinc Paste ( Penetrox, Noalox or equivalent) container.....	2

# 8-30LP9 PARTS & HARDWARE

## IN HARDWARE BAG

Bolt, 3/8-16 x 5-1/2", stainless.....	16
Bolt, 3/8-16 x 4-1/2" stainless.....	2
Nut, 3/8-16, locking, stainless.....	26
Bolt, 5/16-18 x 2-1/2" stainless.....	12
Nut, 5/6-18, locking, stainless.....	12
Nut, 5/16-18 stainless.....	4
Lock washer, 5/16" split ring, stainless.....	4
Bolt, 1/4-20 x 5" stainless.....	2
Bolt, 1/4-20 x 3-1/2" stainless.....	2
Bolt, 1/4-20 x 2-3/4" stainless.....	14
Bolt, 1/4-20 x 2-1/4" stainless.....	6
Bolt, 1/4-20 x 2.0" stainless.....	6
Bolt, 1/4-20 x 1-3/4" stainless.....	18
Bolt, 1/4-20 x 1-1/2" stainless.....	8
Bolt, 1/4-20 x 1-1/4" stainless.....	4
Bolt, 1/4-20 x 1" stainless.....	4
Screw, 1/4-20 x 1" countersunk, flathead, stainless.....	16
Nut, 1/4-20 locking, stainless.....	68
Screw, 8-32 x 2" panhead stainless.....	6
Screw, 8-32 x 1-3/4" panhead, stainless.....	18
Screw, 8-32 x 1-1/2" panhead, stainless.....	26
Screw, 8-32 x 1-1/4" panhead, stainless.....	40
Screw, 8-32 x 1.0" panhead, stainless.....	42
Nut, 8-32 locking, stainless.....	132
Set screw, 8-32 x 1/4 stainless.....	8
Shaft retainer, 3/16 stainless.....	8
Push tube 3/8 x 3" alum.....	1
Allen wrench 5/64".....	2

## **M<sup>2</sup> ANTENNA SYSTEMS, INC.**

4402 N. SELAND AVE.

FRESNO, CA 93722

(559) 432-8873 FAX: 432-3059

[www.m2inc.com](http://www.m2inc.com) Email: [sales@m2inc.com](mailto:sales@m2inc.com)