

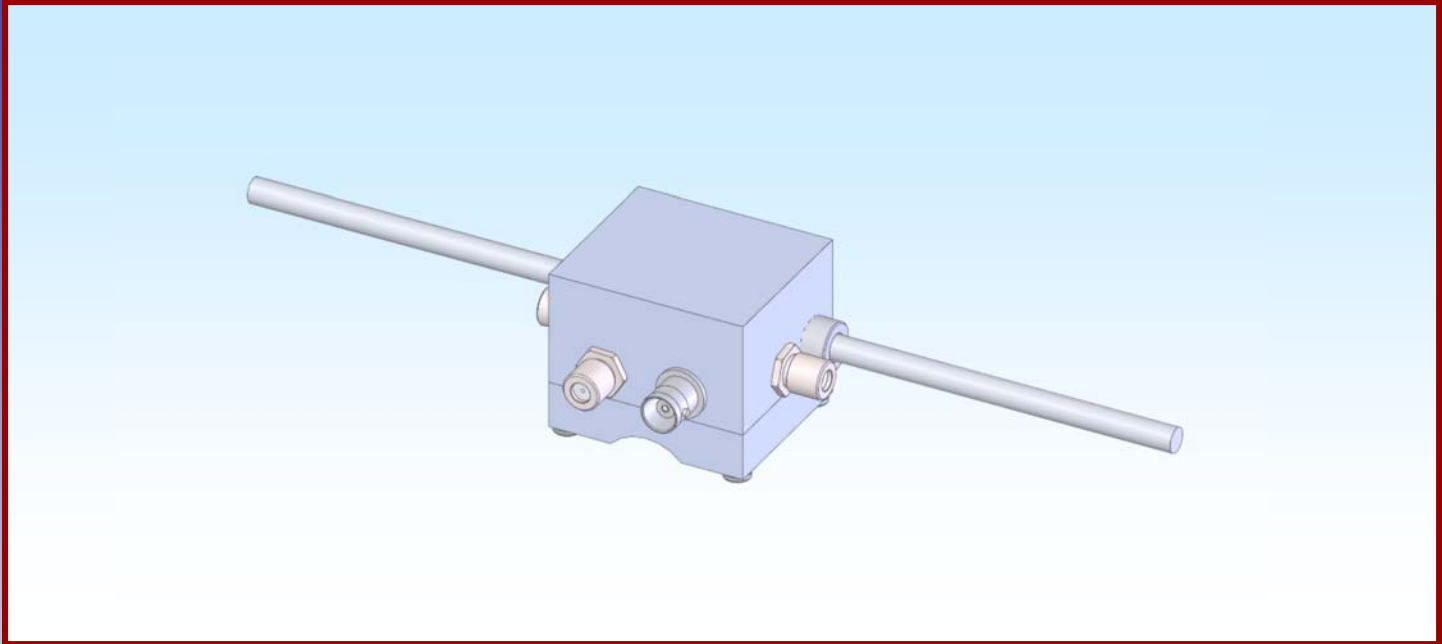

M2 Antenna Systems, Inc. Model No: FGPS-2MS



SPECIFICATIONS:

| | | | |
|-----------------------|--------------------|-----------------------------|-------------------------|
| Model No | FGPS-2MS | Switch Time, In / Out | 20ms / 15ms |
| Frequency Range | 144-148 MHz | Power Handling | 200 W |
| Isolation | 50 dB | DC power req. | 12 VDC @ 80mA |
| Feed Impedance..... | 50 Ohms Unbalanced | Block size / Rod Dia | 2" X 2" X 1-1/4" / 1/4" |
| VSWR..... | 1.2:1 or better | Maximum Element Length..... | 50" |
| Connectors | "F" Female | Operating Temp range | -50°c to 150°c |
| Insertion Loss | 0.1 dB | Weight / Ship Wt..... | 2.0 Lbs. |

***Subtract 2.14 from dBi for dBd**

FEATURES:

The FGPS-2MS polarity switch kit is designed to work with the 2MCP8A and 2MCP12. It allows instantaneous selection of right or left hand circularity. Originally designed for NASA for many of their 100 to 500 MHz satellite and space craft applications, the FGPS-2MS is now used by many amateur VHF enthusiasts to performance flexibility to both terrestrial and satellite applications.

The heart of the unit is a small, low loss coaxial switch carefully designed into the driven element block. Only one FGPS-2MS per antenna is required to achieve full right hand and left hand selection. The FGPS-2MS can handle 200W of continuous RF transmission power. Losses are less than 0.1 dB.

Installation is easy and involves the removal of one of the original Driven Element assemblies and then mounting the FGPS-2MS in its place. M2 Antennas has polarity switches available for our commercial antennas for popular frequencies. Polarity switches can also be designed for any of our custom antennas based on your requirements. Please contact us with your requirements.

2MCP8A WITH POLARITY SWITCH DIMENSION SHEET

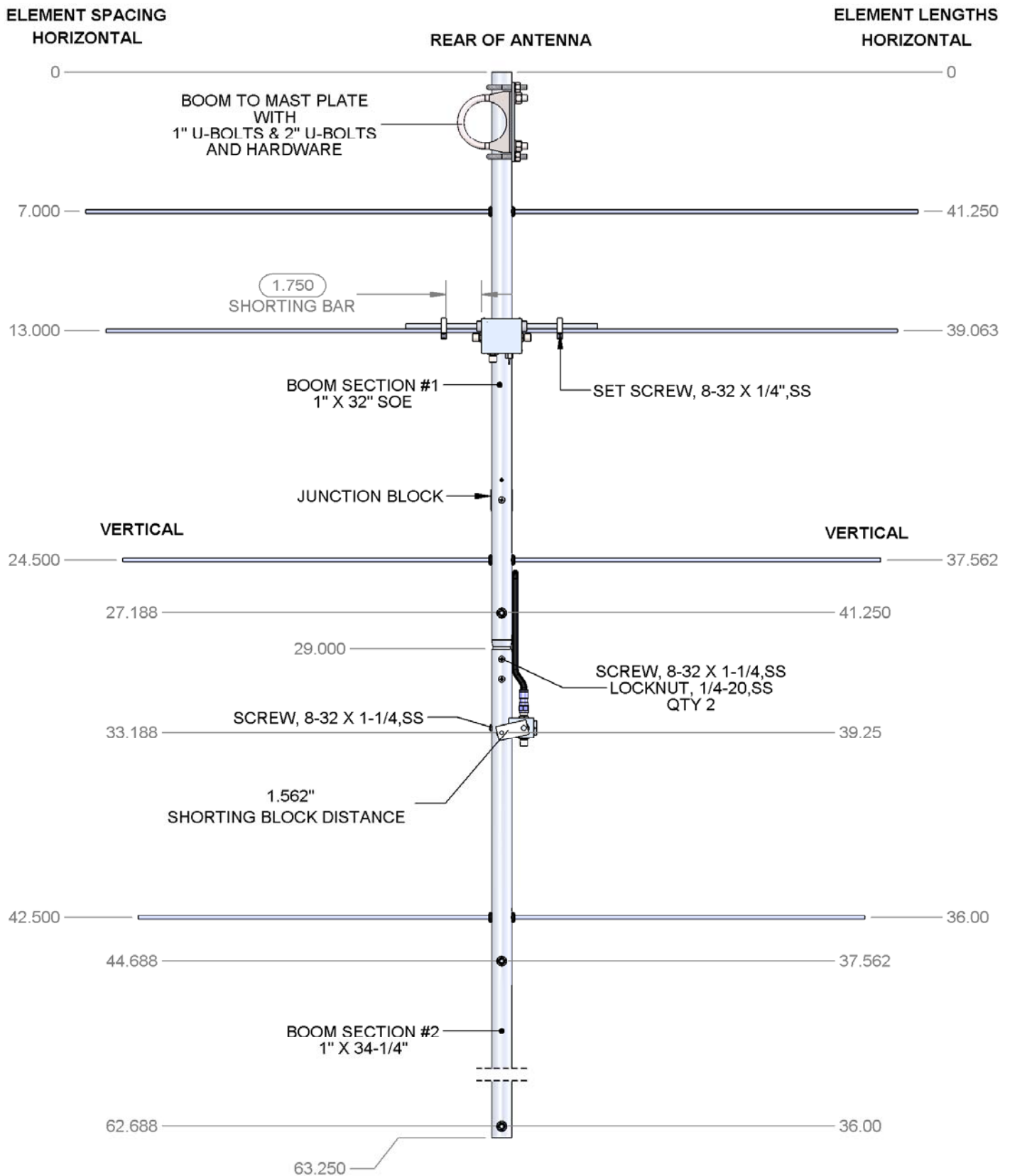

2MCP12 WITH POLARITY SWITCH DIMENSION SHEET

ELEMENT SPACING
HORIZONTAL

2MCP12 WITH POLARITY SWITCH DIMENSIONS

ELEMENT LENGTH
HORIZONTAL

NOTE:

SHOWN IN RIGHT HAND CIRCULARITY

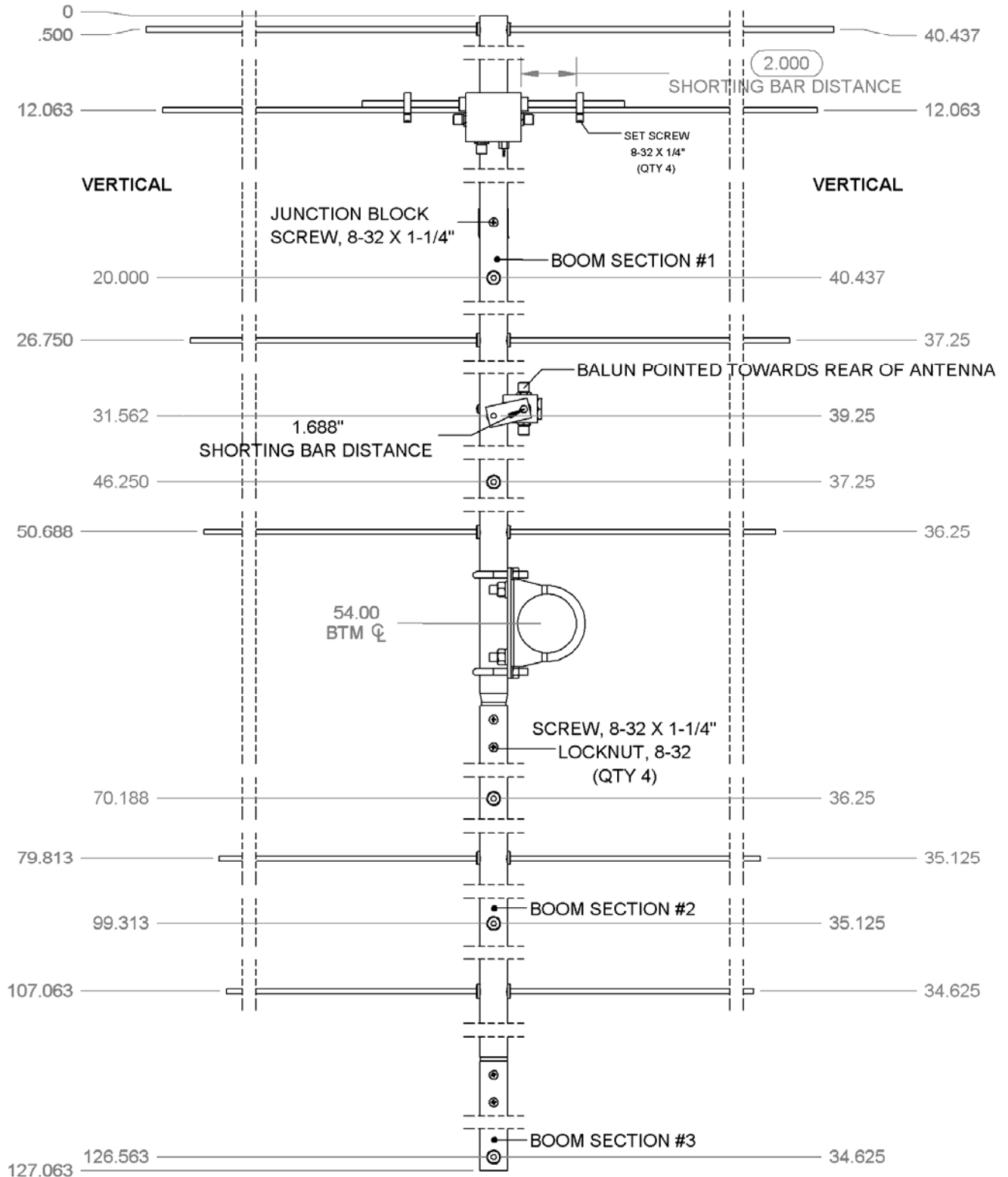

FGPS-2MS ASSEMBLY MANUAL

TOOLS REQUIRED FOR ASSEMBLY: screwdriver, 11/32 nut driver/wrench, a 7/16" and 1/2" end wrench.

REFER TO THE ENCLOSED DIMENSION SHEET.

1. Loosen the set screws in the shorting bars in the rear driven element. WD40 lubricant will aid in loosening the set screws in the shorting bars if they have been in a hostile environment for some length of time. Remove the shorting bars from each side so the rear driven element can be completely removed from the antenna..
2. Attach the polarity switch with the 8-32 x 1-1/4" screw in the REAR hole. Orient the polarity switch so it matches the DIMENSION SHEET. The polarity switch should be mounted as shown or the RHC, default circularity may be reversed.
3. Attach the original 1/4 wave phase line and the 1/2 wave balun. Tighten the connectors gently with a 7/16" end wrench.
4. Re-install the shorting bars on the polarity switch. Set the bars at the dimension shown on the "ANTENNA DIMENSION" sheet .
5. The power input connector is a female BNC connector, M2 suggests to use a inexpensive shielded coax like RG-58 with a male BNC connector on one end. Power should be applied to the center conductor of the coax and the shield should be grounded. Attach the coax to the BNC connector on the new D.E. block and route it to the rear. Attach MAIN FEED LINE AGAIN and secure it and the dc control coax to the rear boom section. Route all cables as shown and keep them close against the boom using the cable ties provided.

TUNE UP AND OPERATION NOTES

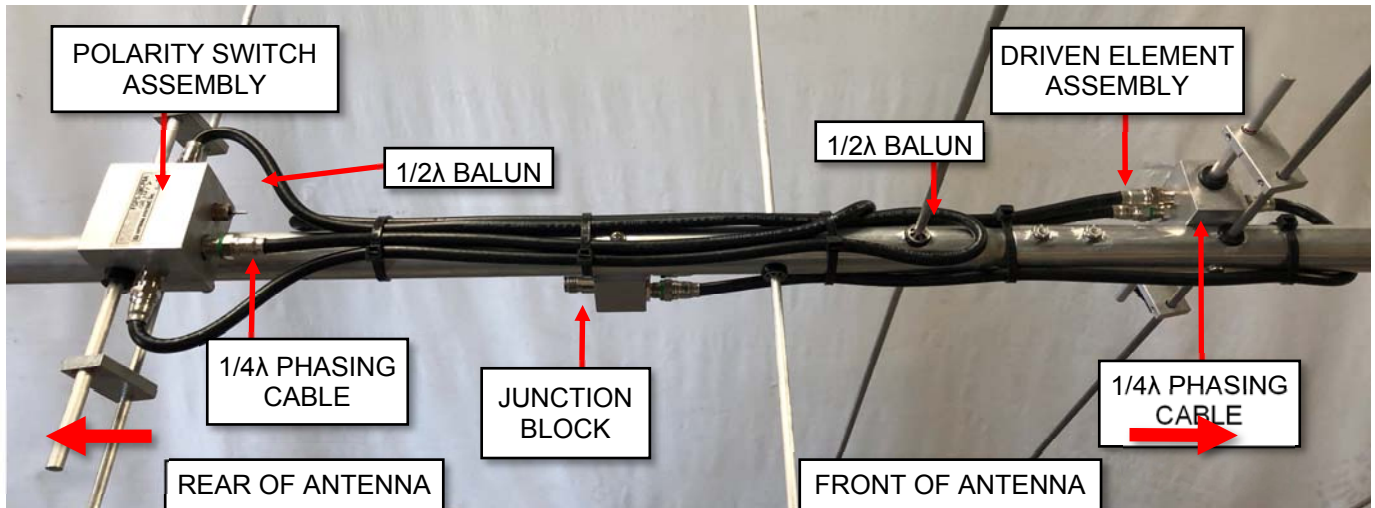

When +12 vdc is applied to the control wire the internal coax relay switches the center conductor of the feed line from one side side of the polarity switch to the other. This inverts the phase of the polarity switch by 180 degrees and subsequently reverses the circularity from RHC TO LHC. Because there are small lead length differences from one phase to the other, you may see a slight change in VSWR when the circularity is reversed. M² has tried to minimize this change by adjusting the polarity switch shorting bar position. Your system may differ slightly and you may have to adjust the shorting bars accordingly.

You may also note a slight overall VSWR change after you do this upgrade. This is normal but again the match change in the satellite band should be minimal and typically under 1.4:1. The change might be greater on either side of the satellite band. Again some adjustment can be done depending on what modes and frequencies you intend to use your antenna.

The 2MCP8A and 2MCP12 are circular polarized antennas and creates fields in all planes or polarities. Performance and VSWR can DETERIORATE SIGNIFICANTLY if they are mounted on a metal (conductive) mast or cross boom. A mast or cross boom of any NON-CONDUCTIVE material must be used. Fiberglass is the best choice for its strength and weather resistance. Please note if the 2MCP8A or 2MCP12 is rear mounted (standard configuration) this restriction does not apply. However, if the 2MCP8A or 2MCP12 is centered mounted, non-conductive material must be used. Try to keep the cable run to under 100 ft. to prevent excessive transmit power loss. Using a good low noise switching preamp at or near the antenna is highly recommended. The preamp will prevent the feedline loss from reducing your overall receive sensitivity. ARR and SSB Electronics both make good 160 watt power handling relays. To maintain proper phasing when stacking two or more antennas, mount each with the same orientation of Driven Element Blocks. DO NOT MOUNT MIRROR IMAGE.

PS-2MS PARTS & HARDWARE

| DESCRIPTION | QTY |
|---|-----|
| POLARITY SWITCH ASSEMBLY (SAPS2MS)..... | 1 |
| SCREW, 8-32 X 1-1/4"..... | 1 |
| SET SCREW, 8-32 X 1/4"..... | 4 |
| CABLE TIES, SMALL..... | 4 |
| ALLEN WRENCH, 5/64"..... | 1 |
| ASSEMBLY / UPGRADE SHEET..... | 1 |

CAREFULLY MANUFACTURED BY:

M² ANTENNA SYSTEMS, INC.

4402 N. Selland Ave.

Fresno, CA 93722

(559) 432-8873 Fax: 432-3059

www.m2inc.com Email: sales@m2inc.com